

Micro Motion® Model 2700 Transmitters with Analog Outputs

Configuration and Use Manual



Safety messages

Safety messages are provided throughout this manual to protect personnel and equipment. Read each safety message carefully before proceeding to the next step.

Micro Motion customer service

Location		Telephone number	Email
U.S.A.		800-522-MASS (800-522-6277) (toll free)	flow.support@emerson.com
Canada and Latin America		+1 303-527-5200 (U.S.A.)	
Asia	Japan	3 5769-6803	
	All other locations	+65 6777-8211 (Singapore)	
Europe	U.K.	0870 240 1978 (toll-free)	
	All other locations	+31 (0) 318 495 555 (The Netherlands)	

Contents

Part I Getting Started

Chapter 1	Before you begin	3
1.1	About this manual	3
1.2	Transmitter model code	3
1.3	Communications tools and protocols	3
1.4	Additional documentation and resources	4
Chapter 2	Quick start	7
2.1	Power up the transmitter	7
2.2	Check flowmeter status	7
2.3	Make a startup connection to the transmitter	9
2.4	Characterize the flowmeter (if required)	10
2.4.1	Sources and formats for characterization parameters	10
2.5	Verify mass flow measurement	13
2.6	Verify the zero	14
2.6.1	Verify the zero using ProLink II	14
2.6.2	Verify the zero using ProLink III	15
2.6.3	Terminology used with zero verification and zero calibration	16

Part II Configuration and commissioning

Chapter 3	Introduction to configuration and commissioning	19
3.1	Configuration flowchart	19
3.2	Default values and ranges	21
3.3	Enable access to the off-line menu of the display	21
3.4	Disable write-protection on the transmitter configuration	21
3.5	Restore the factory configuration	22
Chapter 4	Configure process measurement	23
4.1	Configure mass flow measurement	23
4.1.1	Configure Mass Flow Measurement Unit	23
4.1.2	Configure Flow Damping	26
4.1.3	Configure Mass Flow Cutoff	27
4.2	Configure volume flow measurement for liquid applications	29
4.2.1	Configure Volume Flow Type for liquid applications	29
4.2.2	Configure Volume Flow Measurement Unit for liquid applications	30
4.2.3	Configure Volume Flow Cutoff	33
4.3	Configure gas standard volume (GSV) flow measurement	34
4.3.1	Configure Volume Flow Type for gas applications	35
4.3.2	Configure Standard Gas Density	35
4.3.3	Configure Gas Standard Volume Flow Measurement Unit	36
4.3.4	Configure Gas Standard Volume Flow Cutoff	39
4.4	Configure Flow Direction	40
4.4.1	Options for Flow Direction	41

4.5	Configure density measurement	45
4.5.1	Configure Density Measurement Unit	46
4.5.2	Configure slug flow parameters	47
4.5.3	Configure Density Damping	48
4.5.4	Configure Density Cutoff	50
4.6	Configure temperature measurement	50
4.6.1	Configure Temperature Measurement Unit	51
4.6.2	Configure Temperature Damping	51
4.7	Configure the petroleum measurement application	53
4.7.1	Configure petroleum measurement using ProLink II	53
4.7.2	Configure petroleum measurement using ProLink III	54
4.7.3	Configure petroleum measurement using the Field Communicator	56
4.7.4	API reference tables	57
4.8	Configure the concentration measurement application	58
4.8.1	Configure concentration measurement using ProLink II	58
4.8.2	Configure concentration measurement using ProLink III	61
4.8.3	Configure concentration measurement using the Field Communicator	64
4.8.4	Standard matrices for the concentration measurement application	66
4.8.5	Derived variables and calculated process variables	67
4.9	Configure pressure compensation	69
4.9.1	Configure pressure compensation using ProLink II	69
4.9.2	Configure pressure compensation using ProLink III	71
4.9.3	Configure pressure compensation using the Field Communicator	73
4.9.4	Options for Pressure Measurement Unit	74
Chapter 5	Configure device options and preferences	77
5.1	Configure the transmitter display	77
5.1.1	Configure the language used for the display	77
5.1.2	Configure the process variables shown on the display	78
5.1.3	Configure the precision of variables shown on the display	79
5.1.4	Configure the refresh rate of data shown on the display	80
5.1.5	Enable or disable automatic scrolling through the display variables	81
5.1.6	Enable or disable the display backlight	81
5.1.7	Enable or disable Status LED Blinking	82
5.2	Enable or disable operator actions from the display	82
5.2.1	Enable or disable Totalizer Start/Stop from the display	83
5.2.2	Enable or disable Totalizer Reset from the display	83
5.2.3	Enable or disable the Acknowledge All Alarms display command	84
5.3	Configure security for the display menus	85
5.4	Configure response time parameters	86
5.4.1	Configure Update Rate	87
5.4.2	Configure Calculation Speed (Response Time)	89
5.5	Configure alarm handling	89
5.5.1	Configure Fault Timeout	90
5.5.2	Configure Status Alarm Severity	90
5.6	Configure informational parameters	94
5.6.1	Configure Descriptor	95
5.6.2	Configure Message	95
5.6.3	Configure Date	96
5.6.4	Configure Sensor Serial Number	96
5.6.5	Configure Sensor Material	97

5.6.6	Configure Sensor Liner Material	97
5.6.7	Configure Sensor Flange Type	98
Chapter 6	Integrate the meter with the control system	99
6.1	Configure the transmitter channels	99
6.2	Configure the mA output	100
6.2.1	Configure mA Output Process Variable	100
6.2.2	Configure Lower Range Value (LRV) and Upper Range Value (URV)	102
6.2.3	Configure AO Cutoff	104
6.2.4	Configure Added Damping	105
6.2.5	Configure mA Output Fault Action and mA Output Fault Level	107
6.3	Configure the frequency output	108
6.3.1	Configure Frequency Output Process Variable	108
6.3.2	Configure Frequency Output Polarity	110
6.3.3	Configure Frequency Output Scaling Method	111
6.3.4	Configure Frequency Output Maximum Pulse Width	112
6.3.5	Configure Frequency Output Fault Action and Frequency Output Fault Level	113
6.4	Configure the discrete output	114
6.4.1	Configure Discrete Output Source	115
6.4.2	Configure Discrete Output Polarity	118
6.4.3	Configure Discrete Output Fault Action	119
6.5	Configure events	120
6.5.1	Configure a basic event	121
6.5.2	Configure an enhanced event	121
6.6	Configure digital communications	124
6.6.1	Configure HART/Bell 202 communications	124
6.6.2	Configure HART/RS-485 communications	129
6.6.3	Configure Modbus/RS-485 communications	130
6.6.4	Configure Digital Communications Fault Action	131
Chapter 7	Completing the configuration	135
7.1	Test or tune the system using sensor simulation	135
7.1.1	Sensor simulation	136
7.2	Back up transmitter configuration	137
7.3	Enable write-protection on the transmitter configuration	138
Chapter 8	Set up the Weights & Measures application	139
8.1	Weights & Measures application	139
8.2	Set up the Weights & Measures application using ProLink II	140
8.3	Set up the Weights & Measures application using ProLink III	143
Part III Operations, maintenance, and troubleshooting		
Chapter 9	Transmitter operation	149
9.1	Record the process variables	149
9.2	View process variables	150
9.2.1	View process variables using the display	150
9.2.2	View process variables using ProLink III	151
9.3	View transmitter status using the status LED	152
9.4	View and acknowledge status alarms	152
9.4.1	View and acknowledge alarms using the display	152
9.4.2	View and acknowledge alarms using ProLink II	155

9.4.3	View and acknowledge alerts using ProLink III	156
9.4.4	View alarms using the Field Communicator	156
9.4.5	Alarm data in transmitter memory	157
9.5	Read totalizer and inventory values	157
9.6	Start and stop totalizers and inventories	158
9.6.1	Start and stop totalizers and inventories using the display	158
9.7	Reset totalizers	160
9.7.1	Reset totalizers using the display	160
9.8	Reset inventories	161
Chapter 10	Operate the transmitter with the Weights & Measures application	163
10.1	Operate the transmitter when the Weights & Measures application is installed	163
10.1.1	Approved methods to read or obtain process data	164
10.1.2	Large totalizer values on the display (OIML applications only)	164
10.1.3	Effect of the Weights & Measures application on process measurement and outputs	165
10.1.4	Effect of the Weights & Measures application on operation and maintenance functions	166
10.2	Switch between secured and unsecured mode	168
10.2.1	Switch between secured and unsecured mode using ProLink II	169
10.2.2	Switch between secured and unsecured mode using ProLink III	169
10.2.3	Switch between secured and unsecured mode using the switching utility	170
10.3	Clear Status Alarm A027: Security Breach	170
10.4	Replacing the core processor in a Weights & Measures installation	171
Chapter 11	Measurement support	173
11.1	Options for measurement support	173
11.2	Use Smart Meter Verification	173
11.2.1	Smart Meter Verification requirements	174
11.2.2	Smart Meter Verification test preparation	174
11.2.3	Run Smart Meter Verification	175
11.2.4	View test data	179
11.2.5	Schedule automatic execution of the Smart Meter Verification test	183
11.3	Zero the flowmeter	186
11.3.1	Zero the flowmeter using the display	187
11.3.2	Zero the flowmeter using ProLink II	188
11.3.3	Zero the flowmeter using ProLink III	189
11.3.4	Zero the flowmeter using the Field Communicator	191
11.4	Validate the meter	192
11.4.1	Alternate method for calculating the meter factor for volume flow	193
11.5	Perform a (standard) D1 and D2 density calibration	194
11.5.1	Perform a D1 and D2 density calibration using ProLink II	194
11.5.2	Perform a D1 and D2 density calibration using ProLink III	196
11.5.3	Perform a D1 and D2 density calibration using the Field Communicator	197
11.6	Perform a D3 and D4 density calibration (T-Series sensors only)	199
11.6.1	Perform a D3 or D3 and D4 density calibration using ProLink II	199
11.6.2	Perform a D3 or D3 and D4 density calibration using ProLink III	200
11.6.3	Perform a D3 or D3 and D4 density calibration using the Field Communicator	201
11.7	Perform temperature calibration	203
Chapter 12	Troubleshooting	207
12.1	Status LED states	208
12.2	Status alarms	208

12.3	Flow measurement problems	220
12.4	Density measurement problems	222
12.5	Temperature measurement problems	223
12.6	Milliamp output problems	224
12.7	Frequency output problems	225
12.8	Use sensor simulation for troubleshooting	226
12.9	Check power supply wiring	227
12.10	Check sensor-to-transmitter wiring	227
12.11	Check grounding	228
12.12	Perform loop tests	228
12.12.1	Perform loop tests using the display	228
12.12.2	Perform loop tests using ProLink II	230
12.12.3	Perform loop tests using ProLink III	231
12.12.4	Perform loop tests using the Field Communicator	233
12.13	Check for radio frequency interference (RFI)	234
12.14	Check the HART communication loop	235
12.15	Check HART Address and Loop Current Mode	235
12.16	Check HART burst mode	236
12.17	Check the trimming of the mA output	236
12.18	Check Lower Range Value and Upper Range Value	236
12.19	Check mA Output Fault Action	236
12.20	Check Frequency Output Maximum Pulse Width	237
12.21	Check Frequency Output Scaling Method	237
12.22	Check Frequency Output Fault Action	237
12.23	Check Flow Direction	237
12.24	Check the cutoffs	238
12.25	Check for slug flow (two-phase flow)	238
12.26	Check the drive gain	239
12.26.1	Collect drive gain data	240
12.27	Check the pickoff voltage	240
12.27.1	Collect pickoff voltage data	241
12.28	Check for electrical shorts	241
12.28.1	Check the sensor coils	242
12.29	Check the core processor LED	243
12.29.1	Core processor LED states	246
12.30	Perform a core processor resistance test	247

Appendices and reference

Appendix A	Using the transmitter display	251
A.1	Components of the transmitter interface	251
A.2	Use the optical switches	252
A.3	Access and use the display menu system	253
A.3.1	Enter a floating-point value using the display	254
A.4	Display codes for process variables	257
A.5	Codes and abbreviations used in display menus	259
A.6	Menu maps for the transmitter display	262
Appendix B	Using ProLink II with the transmitter	273
B.1	Basic information about ProLink II	273
B.2	Connect with ProLink II	274
B.2.1	ProLink II connection types	274

B.2.2	Make a service port connection	275
B.2.3	Make a HART/Bell 202 connection	276
B.2.4	Make a HART/RS-485 connection	281
B.2.5	Make a Modbus/RS-485 connection	284
B.3	Menu maps for ProLink II	287
Appendix C	Using ProLink III with the transmitter	297
C.1	Basic information about ProLink III	297
C.2	Connect with ProLink III	298
C.2.1	ProLink III connection types	298
C.2.2	Make a service port connection	299
C.2.3	Make a HART/Bell 202 connection	300
C.2.4	Make a HART/RS-485 connection	305
C.2.5	Make a Modbus/RS-485 connection	308
C.3	Menu maps for ProLink III	311
Appendix D	Using the Field Communicator with the transmitter	321
D.1	Basic information about the Field Communicator	321
D.2	Connect with the Field Communicator	322
D.3	Menu maps for the Field Communicator	324
Appendix E	Default values and ranges	341
E.1	Default values and ranges	341
Appendix F	Transmitter components and installation wiring	347
F.1	Installation types	347
F.2	Power supply terminals and ground	351
F.3	Input/output (I/O) wiring terminals	352
Appendix G	NE 53 history	353
G.1	NE 53 history	353
Index	357

Part I

Getting Started

Chapters covered in this part:

- *Before you begin*
- *Quick start*

1 Before you begin

Topics covered in this chapter:

- [About this manual](#)
- [Transmitter model code](#)
- [Communications tools and protocols](#)
- [Additional documentation and resources](#)

1.1 About this manual

This manual provides information to help you configure, commission, use, maintain, and troubleshoot the Micro Motion Model 2700 transmitter.

Important

This manual assumes that the transmitter has been installed correctly and completely, according to the instructions in the transmitter installation manual, and that the installation complies with all applicable safety requirements.

1.2 Transmitter model code

Your transmitter can be identified by the model number on the transmitter tag.

The transmitter has a model number of the following form:

2700(I/R/C/B)A*******

- I** Integral mount
- R** 4-wire remote-mount
- C** 9-wire remote-mount
- B** Remote core processor with remote transmitter
- A** Analog outputs option board

1.3 Communications tools and protocols

You can use several different communications tools and protocols to interface with the transmitter. You may use different tools in different locations or for different tasks.

Table 1-1: Communications tools, protocols, and related information

Communications tool	Supported protocols	Scope	In this manual	For more information
Display	Not applicable	Basic configuration and commissioning	Complete user information. See Appendix A .	Not applicable
ProLink II	<ul style="list-style-type: none"> HART/RS-485 HART/Bell 202 Modbus/RS-485 Service port 	Complete configuration and commissioning	Basic user information. See Appendix B .	User manual <ul style="list-style-type: none"> Installed with software On Micro Motion user documentation CD On Micro Motion web site (www.micromotion.com)
ProLink III	<ul style="list-style-type: none"> HART/RS-485 HART/Bell 202 Modbus/RS-485 Service port 	Complete configuration and commissioning	Basic user information. See Appendix C .	User manual <ul style="list-style-type: none"> Installed with software On Micro Motion user documentation CD On Micro Motion web site (www.micromotion.com)
Field Communicator	HART/Bell 202	Complete configuration and commissioning	Basic user information. See Appendix D .	User manual on Micro Motion web site (www.micromotion.com)

Tip

You may be able to use other communications tools from Emerson Process Management, such as AMS Suite: Intelligent Device Manager, or the Smart Wireless THUM™ Adapter. Use of AMS or the Smart Wireless THUM Adapter is not discussed in this manual. The AMS interface is similar to the ProLink II interface. For more information on the Smart Wireless THUM Adapter, refer to the documentation available at www.micromotion.com.

1.4 Additional documentation and resources

Micro Motion provides additional documentation to support the installation and operation of the transmitter.

Table 1-2: Additional documentation and resources

Topic	Document
Sensor	Sensor documentation

Table 1-2: Additional documentation and resources (continued)

Topic	Document
Transmitter installation	<i>Micro Motion Model 1700 and Model 2700 Transmitters: Installation Manual</i>
Hazardous area installation	See the approval documentation shipped with the transmitter, or download the appropriate documentation from the Micro Motion web site at www.micromotion.com .

All documentation resources are available on the Micro Motion web site at www.micromotion.com or on the Micro Motion user documentation CD.

2 Quick start

Topics covered in this chapter:

- *Power up the transmitter*
- *Check flowmeter status*
- *Make a startup connection to the transmitter*
- *Characterize the flowmeter (if required)*
- *Verify mass flow measurement*
- *Verify the zero*

2.1 Power up the transmitter

The transmitter must be powered up for all configuration and commissioning tasks, or for process measurement.

1. Ensure that all transmitter and sensor covers and seals are closed.

CAUTION!

To prevent ignition of flammable or combustible atmospheres, ensure that all covers and seals are tightly closed. For hazardous area installations, applying power while housing covers are removed or loose can cause an explosion.

2. Turn on the electrical power at the power supply.

The transmitter will automatically perform diagnostic routines. During this period, Alarm 009 is active. The diagnostic routines should complete in approximately 30 seconds. For transmitters with a display, the status LED will turn green and begin to flash when the startup diagnostics are complete. If the status LED exhibits different behavior, an alarm condition is present.

Postrequisites

Although the sensor is ready to receive process fluid shortly after power-up, the electronics can take up to 10 minutes to reach thermal equilibrium. Therefore, if this is the initial startup, or if power is been off long enough to allow components to reach ambient temperature, allow the electronics to warm up for approximately 10 minutes before relying on process measurements. During this warm-up period, you may observe minor measurement instability or inaccuracy.

2.2 Check flowmeter status

Check the flowmeter for any error conditions that require user action or that affect measurement accuracy.

1. Wait approximately 10 seconds for the power-up sequence to complete.
Immediately after power-up, the transmitter runs through diagnostic routines and checks for error conditions. During the power-up sequence, Alarm A009 is active. This alarm should clear automatically when the power-up sequence is complete.
2. Check the status LED on the transmitter.

Table 2-1: Transmitter status reported by status LED

LED state	Description	Recommendation
Green	No alarms are active.	Continue with configuration or process measurement.
Flashing green ⁽¹⁾	No alarms are active. One or more previously active alarms have not been acknowledged.	Continue with configuration or process measurement. If you choose, you can acknowledge the alarms.
Yellow	One or more low-severity alarms are active, and have been acknowledged.	A low-severity alarm condition does not affect measurement accuracy or output behavior. You can continue with configuration or process measurement. If you choose, you can identify and resolve the alarm condition.
Flashing yellow ⁽²⁾	One or more low-severity alarms are active and have not been acknowledged.	A low-severity alarm condition does not affect measurement accuracy or output behavior. You can continue with configuration or process measurement. If you choose, you can identify and resolve the alarm condition. You may also acknowledge the alarm.
Red	One or more high-severity alarms are active, and have been acknowledged.	A high-severity alarm condition affects measurement accuracy and output behavior. Resolve the alarm condition before continuing.
Flashing red ⁽³⁾	One or more high-severity alarms are active and have not been acknowledged.	A high-severity alarm condition affects measurement accuracy and output behavior. Resolve the alarm condition before continuing. You may also acknowledge the alarm.

Postrequisites

For information on viewing the list of active alarms, see [Section 9.4](#).

For information on individual alarms and suggested resolutions, see [Section 12.2](#).

(1) If Status LED Blinking is disabled, the LED will show solid green rather than flashing.

(2) If Status LED Blinking is disabled, the LED will show solid yellow rather than flashing.

(3) If Status LED Blinking is disabled, the LED will show solid red rather than flashing.

2.3 Make a startup connection to the transmitter

For all configuration tools except the display, you must have an active connection to the transmitter to configure the transmitter. Follow this procedure to make your first connection to the transmitter.

Identify the connection type to use, and follow the instructions for that connection type in the appropriate appendix. Use the default communications parameters shown in the appendix.

Communications tool	Connection type to use	Instructions
ProLink II	HART/RS-485	Appendix B
ProLink III	HART/RS-485	Appendix C
Field Communicator	HART	Appendix D

Postrequisites

(Optional) Change the communications parameters to site-specific values.

To change the communications parameters using ProLink II:

- To change the protocol, baud rate, parity, or stop bits, choose ProLink > Configuration > RS-485.
- To change the address, choose ProLink > Configuration > Device.

To change the communications parameters using ProLink III, choose Device Tools > Configuration > Communications.

To change the communications parameters using the Field Communicator, choose On-Line Menu > Configure > Manual Setup > Inputs/Outputs > Communications.

Important

If you are changing communications parameters for the connection type that you are using, you will lose the connection when you write the parameters to the transmitter. Reconnect using the new parameters.

2.4 Characterize the flowmeter (if required)

Display	<i>Not available</i>
ProLink II	<ul style="list-style-type: none"> • ProLink > Configuration > Device > Sensor Type • ProLink > Configuration > Flow • ProLink > Configuration > Density • ProLink > Configuration > T Series
ProLink III	Device Tools > Calibration Data
Field Communicator	Configure > Manual Setup > Characterize

Overview

Characterizing the flowmeter adjusts your transmitter to match the unique traits of the sensor it is paired with. The characterization parameters (also called calibration parameters) describe the sensor's sensitivity to flow, density, and temperature. Depending on your sensor type, different parameters are required. Values for your sensor are provided by Micro Motion on the sensor tag or the calibration certificate.

Tip

If your flowmeter was ordered as a unit, it has already been characterized at the factory. However, you should still verify the characterization parameters.

Procedure

1. Specify Sensor Type.
 - Straight-tube (T-Series)
 - Curved-tube (all sensors except T-Series)
2. Set the flow characterization parameters. Be sure to include all decimal points.
 - For straight-tube sensors, set FCF (Flow Cal or Flow Calibration Factor), FTG, and FFQ.
 - For curved-tube sensors, set Flow Cal (Flow Calibration Factor).
3. Set the density characterization parameters.
 - For straight-tube sensors, set D1, D2, DT, DTG, K1, K2, FD, DFQ1, and DFQ2.
 - For curved-tube sensors, set D1, D2, TC, K1, K2, and FD. (TC is sometimes shown as DT.)

2.4.1 Sources and formats for characterization parameters

Different sensor tags display characterization parameters differently. On older sensors, the sensor tag may not contain all the required parameters.

Sample sensor tags

Sample sensor tags are shown in the following illustrations:

- Older curved-tube sensors (all sensors except T-Series): see [Figure 2-1](#)
- Newer curved-tube sensors (all sensors except T-Series): see [Figure 2-2](#)
- Older straight-tube sensors (T-Series): see [Figure 2-3](#)
- Newer straight-tube sensors (T-Series): see [Figure 2-4](#)

Figure 2-1: Tag on older curved-tube sensors (all sensors except T-Series)

```

Sensor                S/N
Meter Type
Meter Factor
Flow Cal Factor 19.0005.13
Dens Cal Factor 12500142864.44
Cal Factor Ref to 0°C
TEMP                °C
TUBE*              CONN**

• MAX. PRESSURE RATING AT 25°C, ACCORDING TO ASME B31.3.
• MAX. PRESSURE RATING AT 25°C, ACCORDING TO ANSI/ASME B16.5 OR MFR'S RATING.

```

Figure 2-2: Tag on newer curved-tube sensors (all sensors except T-Series)

```

MODEL
S/N
FLOW CAL* 19.0005.13
DENS CAL* 12502142824.44
  D1 0.0010   K1 12502.000
  D2 0.9980   K2 14282.000
  TC 4.44000  FD 310
TEMP RANGE      TO      C
TUBE**  CONN***  CASE**

* CALIBRATION FACTORS REFERENCE TO 0 °C
** MAXIMUM PRESSURE RATING AT 25 °C, ACCORDING TO ASME B31.3
*** MAXIMUM PRESSURE RATING AT 25°C, ACCORDING TO ANSI/ASME B16.5 OR MFR'S RATING

```

Figure 2-3: Tag on older straight-tube sensor (T-Series)

```

MODEL T100T628SCAZEZZZZ S/N 1234567890
FLOW FCF X.XXXX FT X.XX
      FTG X.XX FFQ X.XX
DENS D1 X.XXXXX K1 XXXXX.XXX
      D2 X.XXXXX K2 XXXXX.XXX
      DT X.XX FD XX.XX
      DTG X.XX DFQ1 XX.XX DFQ2 X.XX
TEMP RANGE -XXX TO XXX C
TUBE* CONN** CASE*
XXXX XXXXX XXXX XXXXXX

* MAXIMUM PRESSURE RATING AT 25°C, ACCORDING TO ASME B31.3
** MAXIMUM PRESSURE RATING AT 25°C, ACCORDING TO ANSI/ASME B16.5, OR MFR'S RATING

```

Figure 2-4: Tag on newer straight-tube sensor (T-Series)

```

MODEL T100T628SCAZEZZZZ S/N 1234567890
FLOW FCF XXXX.XX.XX
      FTG X.XX FFQ X.XX
DENS D1 X.XXXXX K1 XXXXX.XXX
      D2 X.XXXXX K2 XXXXX.XXX
      DT X.XX FD XX.XX
      DTG X.XX DFQ1 XX.XX DFQ2 X.XX
TEMP RANGE -XXX TO XXX C
TUBE* CONN** CASE*
XXXX XXXXX XXXX XXXXXX

* MAXIMUM PRESSURE RATING AT 25°C, ACCORDING TO ASME B31.3
** MAXIMUM PRESSURE RATING AT 25°C, ACCORDING TO ANSI/ASME B16.5, OR MFR'S RATING

```

Density calibration parameters (D1, D2, K1, K2, FD, TC)

If your sensor tag does not show a D1 or D2 value:

- For D1, enter the Dens A or D1 value from the calibration certificate. This value is the line-condition density of the low-density calibration fluid. Micro Motion uses air. If you cannot find a Dens A or D1 value, enter 0.001 g/cm³.
- For D2, enter the Dens B or D2 value from the calibration certificate. This value is the line-condition density of the high-density calibration fluid. Micro Motion uses water. If you cannot find a Dens B or D2 value, enter 0.998 g/cm³.

If your sensor tag does not show a K1 or K2 value:

- For K1, enter the first 5 digits of the density calibration factor. In the sample tag, this value is shown as 12500 (see [Figure 2-1](#)).
- For K2, enter the second 5 digits of the density calibration factor. In the sample tag, this value is shown as 14286 (see [Figure 2-1](#)).

If your sensor does not show an FD value, contact Micro Motion customer service.

If your sensor tag does not show a DT or TC value, enter the last 3 digits of the density calibration factor. In the sample tag, this value is shown as 4.44 (see [Figure 2-1](#)).

Flow calibration parameters (FCF, FT)

Two separate values are used to describe flow calibration: a 6-character FCF value and a 4-character FT value. Both values contain decimal points. During characterization, these may be entered as two values or as a single 10-character string. The 10-character string is called either Flowcal or FCF.

If your sensor tag shows the FCF and the FT values separately and you need to enter a single value, concatenate the two values to form the single parameter value.

If your sensor tag shows a concatenated Flowcal or FCF value and you need to enter the FCF and the FT values separately, split the concatenated value:

- FCF = The first 6 characters, including the decimal point
- FT = The last 4 characters, including the decimal point

Example: Concatenating FCF and FT

```
FCF = x.xxxx
FT = y.yy
Flow calibration parameter: x.xxxx.yy
```

Example: Splitting the concatenated Flowcal or FCF value

```
Flow calibration parameter: x.xxxx.yy
FCF = x.xxxx
FT = y.yy
```

2.5 Verify mass flow measurement

Check to see that the mass flow rate reported by the transmitter is accurate. You can use any available method.

- Read the value for Mass Flow Rate on the transmitter display.
- Connect to the transmitter with ProLink II and read the value for Mass Flow Rate in the Process Variables window (ProLink > Process Variables).
- Connect to the transmitter with ProLink III and read the value for Mass Flow Rate in the Process Variables panel.
- Connect to the transmitter with the Field Communicator and read the value for Mass Flow Rate in the Process Variables menu (On-Line Menu > Overview > Primary Purpose Variables).

Postrequisites

If the reported mass flow rate is not accurate:

- Check the characterization parameters.

- Review the troubleshooting suggestions for flow measurement issues. See [Section 12.3](#).

2.6 Verify the zero

Verifying the zero helps you determine if the stored zero value is appropriate to your installation, or if a field zero can improve measurement accuracy.

The zero verification procedure analyzes the Live Zero value under conditions of zero flow, and compares it to the Zero Stability range for the sensor. If the average Live Zero value is within a reasonable range, the zero value stored in the transmitter is valid. Performing a field calibration will not improve measurement accuracy.

2.6.1 Verify the zero using ProLink II

Verifying the zero helps you determine if the stored zero value is appropriate to your installation, or if a field zero can improve measurement accuracy.

Important

In most cases, the factory zero is more accurate than the field zero. Do not zero the flowmeter unless one of the following is true:

- The zero is required by site procedures.
- The stored zero value fails the zero verification procedure.

Prerequisites

ProLink II v2.94 or later

Important

Do not verify the zero or zero the flowmeter if a high-severity alarm is active. Correct the problem, then verify the zero or zero the flowmeter. You may verify the zero or zero the flowmeter if a low-severity alarm is active.

Procedure

1. Prepare the flowmeter:
 - a. Allow the flowmeter to warm up for at least 20 minutes after applying power.
 - b. Run the process fluid through the sensor until the sensor temperature reaches the normal process operating temperature.
 - c. Stop flow through the sensor by shutting the downstream valve, and then the upstream valve if available.
 - d. Verify that the sensor is blocked in, that flow has stopped, and that the sensor is completely full of process fluid.
2. Choose ProLink > Calibration > Zero Verification and Calibration > Verify Zero and wait until the procedure completes.

3. If the zero verification procedure fails:
 - a. Confirm that the sensor is completely blocked in, that flow has stopped, and that the sensor is completely full of process fluid.
 - b. Verify that the process fluid is not flashing or condensing, and that it does not contain particles that can settle out.
 - c. Repeat the zero verification procedure.
 - d. If it fails again, zero the flowmeter.For instructions on zeroing the flowmeter, see [Section 11.3](#).

Postrequisites

Restore normal flow through the sensor by opening the valves.

2.6.2 Verify the zero using ProLink III

Verifying the zero helps you determine if the stored zero value is appropriate to your installation, or if a field zero can improve measurement accuracy.

Important

In most cases, the factory zero is more accurate than the field zero. Do not zero the flowmeter unless one of the following is true:

- The zero is required by site procedures.
- The stored zero value fails the zero verification procedure.

Prerequisites

ProLink III v1.0 with Patch Build 31, or a later release

Important

Do not verify the zero or zero the flowmeter if a high-severity alarm is active. Correct the problem, then verify the zero or zero the flowmeter. You may verify the zero or zero the flowmeter if a low-severity alarm is active.

Procedure

1. Prepare the flowmeter:
 - a. Allow the flowmeter to warm up for at least 20 minutes after applying power.
 - b. Run the process fluid through the sensor until the sensor temperature reaches the normal process operating temperature.
 - c. Stop flow through the sensor by shutting the downstream valve, and then the upstream valve if available.
 - d. Verify that the sensor is blocked in, that flow has stopped, and that the sensor is completely full of process fluid.
2. Choose Device Tools > Device Calibration > Zero Verification and Calibration > Verify Zero and wait until the procedure completes.

3. If the zero verification procedure fails:
 - a. Confirm that the sensor is completely blocked in, that flow has stopped, and that the sensor is completely full of process fluid.
 - b. Verify that the process fluid is not flashing or condensing, and that it does not contain particles that can settle out.
 - c. Repeat the zero verification procedure.
 - d. If it fails again, zero the flowmeter.

For instructions on zeroing the flowmeter, see [Section 11.3](#).

Postrequisites

Restore normal flow through the sensor by opening the valves.

2.6.3 Terminology used with zero verification and zero calibration

Table 2-2: Terminology used with zero verification and zero calibration

Term	Definition
Zero	In general, the offset required to synchronize the left pickoff and the right pickoff under conditions of zero flow. Unit = microseconds.
Factory Zero	The zero value obtained at the factory, under laboratory conditions.
Field Zero	The zero value obtained by performing a zero calibration outside the factory.
Prior Zero	The zero value stored in the transmitter at the time a field zero calibration is begun. May be the factory zero or a previous field zero.
Manual Zero	The zero value stored in the transmitter, typically obtained from a zero calibration procedure. It may also be configured manually. Also called “mechanical zero” or “stored zero.”
Live Zero	The real-time bidirectional mass flow rate with no flow damping or mass flow cutoff applied. An adaptive damping value is applied only when the mass flow rate changes dramatically over a very short interval. Unit = configured mass flow measurement unit.
Zero Stability	A laboratory-derived value used to calculate the expected accuracy for a sensor. Under laboratory conditions at zero flow, the average flow rate is expected to fall within the range defined by the Zero Stability value ($0 \pm$ Zero Stability). Each sensor size and model has a unique Zero Stability value. Statistically, 95% of all data points should fall within the range defined by the Zero Stability value.
Zero Calibration	The procedure used to determine the zero value.
Zero Time	The time period over which the Zero Calibration procedure is performed. Unit = seconds.
Field Verification Zero	A 3-minute running average of the Live Zero value, calculated by the transmitter. Unit = configured mass flow measurement unit.
Zero Verification	A procedure used to evaluate the stored zero and determine whether or not a field zero can improve measurement accuracy.

Part II

Configuration and commissioning

Chapters covered in this part:

- *Introduction to configuration and commissioning*
- *Configure process measurement*
- *Configure device options and preferences*
- *Integrate the meter with the control system*
- *Completing the configuration*
- *Set up the Weights & Measures application*

3 Introduction to configuration and commissioning

Topics covered in this chapter:

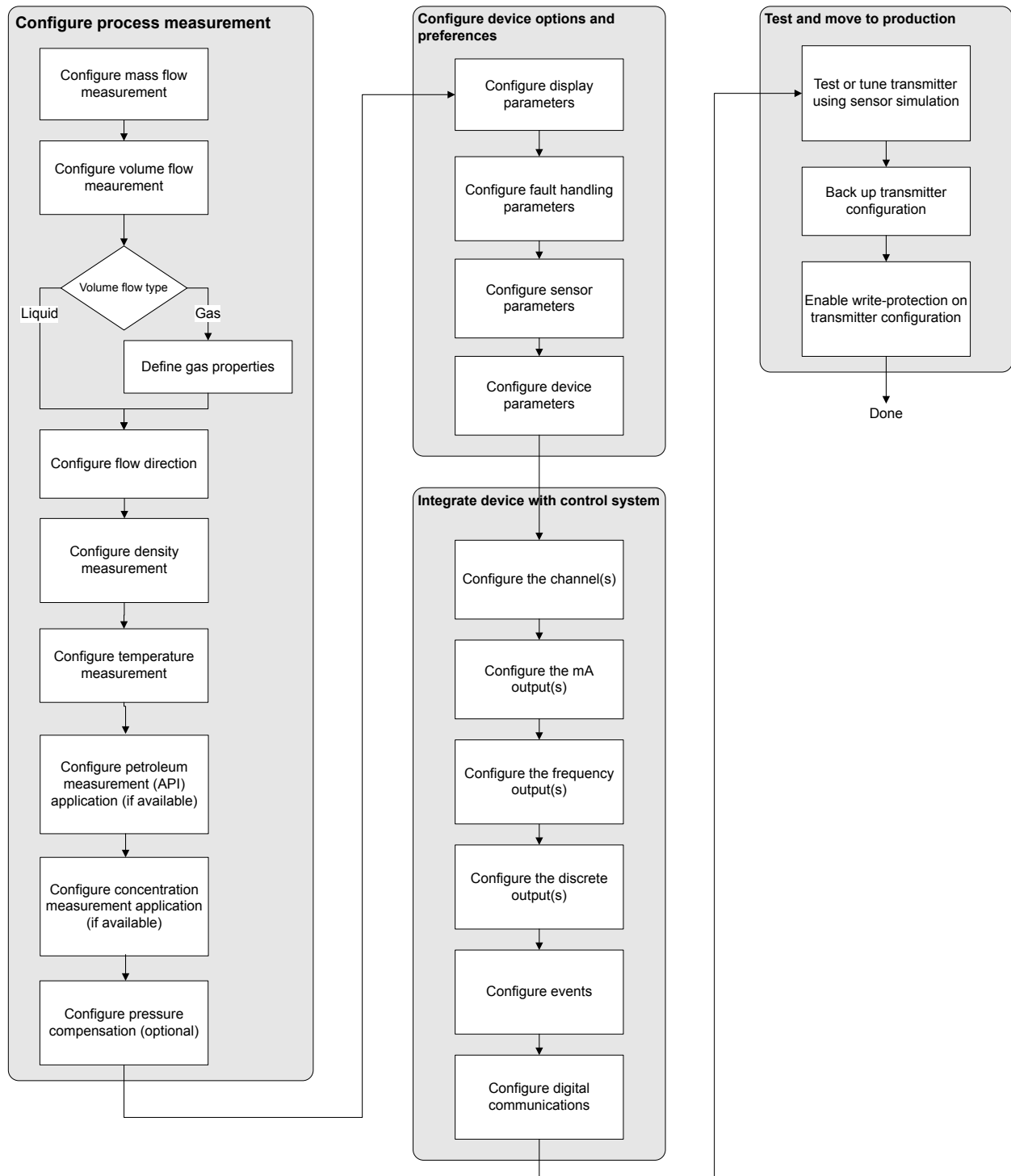
- *Configuration flowchart*
- *Default values and ranges*
- *Enable access to the off-line menu of the display*
- *Disable write-protection on the transmitter configuration*
- *Restore the factory configuration*

3.1 Configuration flowchart

Use the following flowchart as a general guide to the configuration and commissioning process.

Some options may not apply to your installation. Detailed information is provided in the remainder of this manual. If you are using the Weights & Measures application, additional configuration and setup are required.

Figure 3-1: Configuration flowchart



3.2 Default values and ranges

See [Section E.1](#) to view the default values and ranges for the most commonly used parameters.

3.3 Enable access to the off-line menu of the display

Display	OFF-LINE MAINT > OFF-LINE CONFIG > DISPLAY
ProLink II	ProLink > Configuration > Display > Display Options
ProLink III	Device Tools > Configuration > Transmitter Display > Display Security
Field Communicator	Configure > Manual Setup > Display > Offline Variable Menu Features

Overview

By default, access to the off-line menu of the display is enabled. If it is disabled, you must enable it if you want to use the display to configure the transmitter.

Restriction

You cannot use the display to enable access to the off-line menu. You must make a connection from another tool.

3.4 Disable write-protection on the transmitter configuration

Display	OFF-LINE MAINT > CONFIG > LOCK
ProLink II	ProLink > Configuration > Device > Enable Write Protection
ProLink III	Device Tools > Configuration > Write-Protection
Field Communicator	Configure > Manual Setup > Info Parameters > Transmitter Info > Write Protect

Overview

If the transmitter is write-protected, the configuration is locked and you must unlock it before you can change any configuration parameters. By default, the transmitter is not write-protected.

Tip

Write-protecting the transmitter prevents accidental changes to configuration. It does not prevent normal operational use. You can always disable write-protection, perform any required configuration changes, then re-enable write-protection.

3.5 Restore the factory configuration

Display	<i>Not available</i>
ProLink II	ProLink > Configuration > Device > Restore Factory Configuration
ProLink III	Device Tools > Configuration Transfer > Restore Factory Configuration
Field Communicator	<i>Not available</i>

Overview

Restoring the factory configuration returns the transmitter to a known operational configuration. This may be useful if you experience problems during configuration.

Tip

Restoring the factory configuration is not a common action. You may want to contact Micro Motion to see if there is a preferred method to resolve any issues.

4 Configure process measurement

Topics covered in this chapter:

- *Configure mass flow measurement*
- *Configure volume flow measurement for liquid applications*
- *Configure gas standard volume (GSV) flow measurement*
- *Configure Flow Direction*
- *Configure density measurement*
- *Configure temperature measurement*
- *Configure the petroleum measurement application*
- *Configure the concentration measurement application*
- *Configure pressure compensation*

4.1 Configure mass flow measurement

The mass flow measurement parameters control how mass flow is measured and reported.

The mass flow measurement parameters include:

- Mass Flow Measurement Unit
- Flow Damping
- Mass Flow Cutoff

4.1.1 Configure Mass Flow Measurement Unit

Display	OFF-LINE MAINT > OFF-LINE CONFIG > UNITS > MASS
ProLink II	ProLink > Configuration > Flow > Mass Flow Units
ProLink III	Device Tools > Configuration > Process Measurement > Flow
Field Communicator	Configure > Manual Setup > Measurements > Flow > Mass Flow Unit

Overview

Mass Flow Measurement Unit specifies the unit of measure that will be used for the mass flow rate. The unit used for mass total and mass inventory is derived from this unit.

Procedure

Set Mass Flow Measurement Unit to the unit you want to use.

The default setting for Mass Flow Measurement Unit is g/sec (grams per second).

Tip

If the measurement unit you want to use is not available, you can define a special measurement unit.

Options for Mass Flow Measurement Unit

The transmitter provides a standard set of measurement units for Mass Flow Measurement Unit, plus one user-defined special measurement unit. Different communications tools may use different labels for the units.

Table 4-1: Options for Mass Flow Measurement Unit

Unit description	Label			
	Display	ProLink II	ProLink III	Field Communicator
Grams per second	G/S	g/sec	g/sec	g/s
Grams per minute	G/MIN	g/min	g/min	g/min
Grams per hour	G/H	g/hr	g/hr	g/h
Kilograms per second	KG/S	kg/sec	kg/sec	kg/s
Kilograms per minute	KG/MIN	kg/min	kg/min	kg/min
Kilograms per hour	KG/H	kg/hr	kg/hr	kg/h
Kilograms per day	KG/D	kg/day	kg/day	kg/d
Metric tons per minute	T/MIN	mTon/min	mTon/min	MeTon/min
Metric tons per hour	T/H	mTon/hr	mTon/hr	MeTon/h
Metric tons per day	T/D	mTon/day	mTon/day	MeTon/d
Pounds per second	LB/S	lbs/sec	lbs/sec	lb/s
Pounds per minute	LB/MIN	lbs/min	lbs/min	lb/min
Pounds per hour	LB/H	lbs/hr	lbs/hr	lb/h
Pounds per day	LB/D	lbs/day	lbs/day	lb/d
Short tons (2000 pounds) per minute	ST/MIN	sTon/min	sTon/min	STon/min
Short tons (2000 pounds) per hour	ST/H	sTon/hr	sTon/hr	STon/h
Short tons (2000 pounds) per day	ST/D	sTon/day	sTon/day	STon/d
Long tons (2240 pounds) per hour	LT/H	lTon/hr	lTon/hr	LTon/h
Long tons (2240 pounds) per day	LT/D	lTon/day	lTon/day	LTon/d
Special unit	SPECL	special	special	Spcl

Define a special measurement unit for mass flow

Display	<i>Not available</i>
ProLink II	ProLink > Configuration > Special Units
ProLink III	Device Tools > Configuration > Process Measurement > Flow > Special Units
Field Communicator	Configure > Manual Setup > Measurements > Special Units > Mass Special Units

Overview

A special measurement unit is a user-defined unit of measure that allows you to report process data, totalizer data, and inventory data in a unit that is not available in the transmitter. A special measurement unit is calculated from an existing measurement unit using a conversion factor.

Note

Although you cannot define a special measurement unit using the display, you can use the display to select an existing special measurement unit, and to view process data using the special measurement unit.

Procedure

1. Specify Base Mass Unit.
Base Mass Unit is the existing mass unit that the special unit will be based on.
2. Specify Base Time Unit.
Base Time Unit is the existing time unit that the special unit will be based on.
3. Calculate Mass Flow Conversion Factor as follows:
 - a. $x \text{ base units} = y \text{ special units}$
 - b. $\text{Mass Flow Conversion Factor} = x/y$
4. Enter Mass Flow Conversion Factor.
5. Set Mass Flow Label to the name you want to use for the mass flow unit.
6. Set Mass Total Label to the name you want to use for the mass total and mass inventory unit.

The special measurement unit is stored in the transmitter. You can configure the transmitter to use the special measurement unit at any time.

Example: Defining a special measurement unit for mass flow

You want to measure mass flow in ounces per second (oz/sec).

1. Set Base Mass Unit to Pounds (lb).
2. Set Base Time Unit to Seconds (sec).
3. Calculate Mass Flow Conversion Factor:

- a. 1 lb/sec = 16 oz/sec
- b. Mass Flow Conversion Factor = $1/16 = 0.0625$
4. Set Mass Flow Conversion Factor to 0.0625.
5. Set Mass Flow Label to oz/sec.
6. Set Mass Total Label to oz.

4.1.2 Configure Flow Damping

Display	<i>Not available</i>
ProLink II	ProLink > Configuration > Flow > Flow Damp
ProLink III	Device Tools > Configuration > Process Measurement > Flow
Field Communicator	Configure > Manual Setup > Measurements > Flow > Flow Damping

Overview

Damping is used to smooth out small, rapid fluctuations in process measurement. Damping Value specifies the time period (in seconds) over which the transmitter will spread changes in the reported process variable. At the end of the interval, the reported process variable will reflect 63% of the change in the actual measured value.

Procedure

Set Flow Damping to the value you want to use.

The default value is 0.8 seconds. The range depends on the core processor type and the setting of Update Rate, as shown in the following table.

Core processor type	Update Rate setting	Flow Damping range
Standard	Normal	0 to 51.2 seconds
	Special	0 to 10.24 seconds
Enhanced	Not applicable	0 to 51.2 seconds

Tips

- A high damping value makes the process variable appear smoother because the reported value changes slowly.
- A low damping value makes the process variable appear more erratic because the reported value changes more quickly.
- The combination of a high damping value and rapid, large changes in flow rate can result in increased measurement error.
- Whenever the damping value is non-zero, the reported measurement will lag the actual measurement because the reported value is being averaged over time.

- In general, lower damping values are preferable because there is less chance of data loss, and less lag time between the actual measurement and the reported value.
- For gas applications, Micro Motion recommends setting Flow Damping to 2.56 or higher.

The value you enter is automatically rounded down to the nearest valid value. Valid damping values are shown in the following table.

Table 4-2: Valid values for Flow Damping

Core processor type	Update Rate setting	Valid damping values
Standard	Normal	0, 0.2, 0.4, 0.8, ... 51.2
	Special	0, 0.04, 0.08, 0.16, ... 10.24
Enhanced	Not applicable	0, 0.2, 0.4, 0.8, ... 51.2

Effect of Flow Damping on volume measurement

Flow Damping affects volume measurement for liquid volume data. Flow Damping also affects volume measurement for gas standard volume data. The transmitter calculates volume data from the damped mass flow data.

Interaction between Flow Damping and Added Damping

In some circumstances, both Flow Damping and Added Damping are applied to the reported mass flow value.

Flow Damping controls the rate of change in flow process variables. Added Damping controls the rate of change reported via the mA output. If mA Output Process Variable is set to Mass Flow Rate, and both Flow Damping and Added Damping are set to non-zero values, flow damping is applied first, and the added damping calculation is applied to the result of the first calculation.

4.1.3 Configure Mass Flow Cutoff

Display	<i>Not available</i>
ProLink II	ProLink > Configuration > Flow > Mass Flow Cutoff
ProLink III	Device Tools > Configuration > Process Measurement > Flow
Field Communicator	Configure > Manual Setup > Measurements > Flow > Mass Flow Cutoff

Overview

Mass Flow Cutoff specifies the lowest mass flow rate that will be reported as measured. All mass flow rates below this cutoff will be reported as 0.

Procedure

Set Mass Flow Cutoff to the value you want to use.

The default value for Mass Flow Cutoff is 0.0 g/sec or a sensor-specific value set at the factory. The recommended setting is 0.05% of the sensor's rated maximum flow rate or a value below the highest expected flow rate. Do not set Mass Flow Cutoff to 0.0 g/sec.

Effect of Mass Flow Cutoff on volume measurement

Mass Flow Cutoff does not affect volume measurement. Volume data is calculated from the actual mass data rather than the reported value.

Interaction between Mass Flow Cutoff and AO Cutoff

Mass Flow Cutoff defines the lowest mass flow value that the transmitter will report as measured. AO Cutoff defines the lowest flow rate that will be reported via the mA output. If mA Output Process Variable is set to Mass Flow Rate, the mass flow rate reported via the mA output is controlled by the higher of the two cutoff values.

Mass Flow Cutoff affects all reported values and values used in other transmitter behavior (e.g., events defined on mass flow).

AO Cutoff affects only mass flow values reported via the mA output.

Example: Cutoff interaction with AO Cutoff lower than Mass Flow Cutoff

Configuration:

- mA Output Process Variable: Mass Flow Rate
- Frequency Output Process Variable: Mass Flow Rate
- AO Cutoff: 10 g/sec
- Mass Flow Cutoff: 15 g/sec

Result: If the mass flow rate drops below 15 g/sec, mass flow will be reported as 0, and 0 will be used in all internal processing.

Example: Cutoff interaction with AO Cutoff higher than Mass Flow Cutoff

Configuration:

- mA Output Process Variable: Mass Flow Rate
- Frequency Output Process Variable: Mass Flow Rate
- AO Cutoff: 15 g/sec
- Mass Flow Cutoff: 10 g/sec

Result:

- If the mass flow rate drops below 15 g/sec but not below 10 g/sec:
 - The mA output will report zero flow.

- The frequency output will report the actual flow rate, and the actual flow rate will be used in all internal processing.
- If the mass flow rate drops below 10 g/sec, both outputs will report zero flow, and 0 will be used in all internal processing.

4.2 Configure volume flow measurement for liquid applications

The volume flow measurement parameters control how liquid volume flow is measured and reported.

The volume flow measurement parameters include:

- Volume Flow Type
- Volume Flow Measurement Unit
- Volume Flow Cutoff

Restriction

You cannot implement both liquid volume flow and gas standard volume flow at the same time. You must choose one or the other.

4.2.1 Configure Volume Flow Type for liquid applications

Display	<i>Not available</i>
ProLink II	ProLink > Configuration > Flow > Vol Flow Type > Liquid Volume
ProLink III	Device Tools > Configuration > Process Measurement > Flow
Field Communicator	Configure > Manual Setup > Measurements > GSV > Volume Flow Type > Liquid

Overview

Volume Flow Type controls whether liquid or gas standard volume flow measurement will be used.

Restriction

If you are using the petroleum measurement application, you must set Volume Flow Type to Liquid. Gas standard volume measurement is incompatible with the petroleum measurement application.

Restriction

If you are using the concentration measurement application, you must set Volume Flow Type to Liquid. Gas standard volume measurement is incompatible with the concentration measurement application.

Procedure

Set Volume Flow Type to Liquid.

4.2.2 Configure Volume Flow Measurement Unit for liquid applications

Display	OFF-LINE MAINT > OFF-LINE CONFIG > UNITS > VOL
ProLink II	ProLink > Configuration > Flow > Vol Flow Units
ProLink III	Device Tools > Configuration > Process Measurement > Flow
Field Communicator	Configure > Manual Setup > Measurements > Flow > Volume Flow Unit

Overview

Volume Flow Measurement Unit specifies the unit of measurement that will be displayed for the volume flow rate. The unit used for the volume total and volume inventory is based on this unit.

Prerequisites

Before you configure Volume Flow Measurement Unit, be sure that Volume Flow Type is set to Liquid.

Procedure

Set Volume Flow Measurement Unit to the unit you want to use.

The default setting for Volume Flow Measurement Unit is l/sec (liters per second).

Tip

If the measurement unit you want to use is not available, you can define a special measurement unit.

Options for Volume Flow Measurement Unit for liquid applications

The transmitter provides a standard set of measurement units for Volume Flow Measurement Unit, plus one user-defined measurement unit. Different communications tools may use different labels for the units.

Table 4-3: Options for Volume Flow Measurement Unit for liquid applications

Unit description	Label			
	Display	ProLink II	ProLink III	Field Communicator
Cubic feet per second	CUFT/S	ft3/sec	ft3/sec	Cuft/s
Cubic feet per minute	CUF/MN	ft3/min	ft3/min	Cuft/min

Table 4-3: Options for Volume Flow Measurement Unit for liquid applications (continued)

Unit description	Label			
	Display	ProLink II	ProLink III	Field Communicator
Cubic feet per hour	CUFT/H	ft3/hr	ft3/hr	Cuft/h
Cubic feet per day	CUFT/D	ft3/day	ft3/day	Cuft/d
Cubic meters per second	M3/S	m3/sec	m3/sec	Cum/s
Cubic meters per minute	M3/MIN	m3/min	m3/min	Cum/min
Cubic meters per hour	M3/H	m3/hr	m3/hr	Cum/h
Cubic meters per day	M3/D	m3/day	m3/day	Cum/d
U.S. gallons per second	USGPS	US gal/sec	US gal/sec	gal/s
U.S. gallons per minute	USGPM	US gal/min	US gal/min	gal/min
U.S. gallons per hour	USGPH	US gal/hr	US gal/hr	gal/h
U.S. gallons per day	USGPD	US gal/day	US gal/day	gal/d
Million U.S. gallons per day	MILG/D	mil US gal/day	mil US gal/day	MMgal/d
Liters per second	L/S	l/sec	l/sec	L/s
Liters per minute	L/MIN	l/min	l/min	L/min
Liters per hour	L/H	l/hr	l/hr	L/h
Million liters per day	MILL/D	mil l/day	mil l/day	ML/d
Imperial gallons per second	UKGPS	Imp gal/sec	Imp gal/sec	Impgal/s
Imperial gallons per minute	UKGPM	Imp gal/min	Imp gal/min	Impgal/min
Imperial gallons per hour	UKGPH	Imp gal/hr	Imp gal/hr	Impgal/h
Imperial gallons per day	UKGPD	Imp gal/day	Imp gal/day	Impgal/d
Barrels per second ⁽¹⁾	BBL/S	barrels/sec	barrels/sec	bbl/s
Barrels per minute ⁽¹⁾	BBL/MN	barrels/min	barrels/min	bbl/min
Barrels per hour ⁽¹⁾	BBL/H	barrels/hr	barrels/hr	bbl/h
Barrels per day ⁽¹⁾	BBL/D	barrels/day	barrels/day	bbl/d
Beer barrels per second ⁽²⁾	BBBL/S	Beer barrels/sec	Beer barrels/sec	bbbl/s
Beer barrels per minute ⁽²⁾	BBBL/MN	Beer barrels/min	Beer barrels/min	bbbl/min
Beer barrels per hour ⁽²⁾	BBBL/H	Beer barrels/hr	Beer barrels/hr	bbbl/h
Beer barrels per day ⁽²⁾	BBBL/D	Beer barrels/day	Beer barrels/day	bbbl/d
Special unit	SPECL	special	special	Spcl

(1) Unit based on oil barrels (42 U.S. gallons).

(2) Unit based on U.S. beer barrels (31 U.S. gallons).

Define a special measurement unit for volume flow

Display	<i>Not available</i>
ProLink II	ProLink > Configuration > Special Units
ProLink III	Device Tools > Configuration > Process Measurement > Flow > Special Units
Field Communicator	Configure > Manual Setup > Measurements > Special Units > Volume Special Units

Overview

A special measurement unit is a user-defined unit of measure that allows you to report process data, totalizer data, and inventory data in a unit that is not available in the transmitter. A special measurement unit is calculated from an existing measurement unit using a conversion factor.

Note

Although you cannot define a special measurement unit using the display, you can use the display to select an existing special measurement unit, and to view process data using the special measurement unit.

Procedure

1. Specify Base Volume Unit.
Base Volume Unit is the existing volume unit that the special unit will be based on.
2. Specify Base Time Unit.
Base Time Unit is the existing time unit that the special unit will be based on.
3. Calculate Volume Flow Conversion Factor as follows:
 - a. $x \text{ base units} = y \text{ special units}$
 - b. $\text{Volume Flow Conversion Factor} = x/y$
4. Enter Volume Flow Conversion Factor.
5. Set Volume Flow Label to the name you want to use for the volume flow unit.
6. Set Volume Total Label to the name you want to use for the volume total and volume inventory unit.

The special measurement unit is stored in the transmitter. You can configure the transmitter to use the special measurement unit at any time.

Example: Defining a special measurement unit for volume flow

You want to measure volume flow in pints per second (pints/sec).

1. Set Base Volume Unit to Gallons (gal).
2. Set Base Time Unit to Seconds (sec).
3. Calculate the conversion factor:

- a. 1 gal/sec = 8 pints/sec
- b. Volume Flow Conversion Factor = $1/8 = 0.1250$
4. Set Volume Flow Conversion Factor to 0.1250.
5. Set Volume Flow Label to pints/sec.
6. Set Volume Total Label to pints.

4.2.3 Configure Volume Flow Cutoff

Display	<i>Not available</i>
ProLink II	ProLink > Configuration > Flow > Vol Flow Cutoff
ProLink III	Device Tools > Configuration > Process Measurement > Flow
Field Communicator	Configure > Manual Setup > Measurements > Flow > Volume Flow Cutoff

Overview

Volume Flow Cutoff specifies the lowest volume flow rate that will be reported as measured. All volume flow rates below this cutoff are reported as 0.

Procedure

Set Volume Flow Cutoff to the value you want to use.

The default value for Volume Flow Cutoff is 0.0 l/sec (liters per second). The lower limit is 0. The upper limit is the sensor's flow calibration factor, in units of l/sec, multiplied by 0.2.

Interaction between Volume Flow Cutoff and AO Cutoff

Volume Flow Cutoff defines the lowest liquid volume flow value that the transmitter will report as measured. AO Cutoff defines the lowest flow rate that will be reported via the mA output. If mA Output Process Variable is set to Volume Flow Rate, the volume flow rate reported via the mA output is controlled by the higher of the two cutoff values.

Volume Flow Cutoff affects both the volume flow values reported via the outputs and the volume flow values used in other transmitter behavior (e.g., events defined on the volume flow).

AO Cutoff affects only flow values reported via the mA output.

Example: Cutoff interaction with AO Cutoff lower than Volume Flow Cutoff

Configuration:

- mA Output Process Variable: Volume Flow Rate
- Frequency Output Process Variable: Volume Flow Rate
- AO Cutoff: 10 l/sec
- Volume Flow Cutoff: 15 l/sec

Result: If the volume flow rate drops below 15 l/sec, volume flow will be reported as 0, and 0 will be used in all internal processing.

Example: Cutoff interaction with AO Cutoff higher than Volume Flow Cutoff

Configuration:

- mA Output Process Variable: Volume Flow Rate
- Frequency Output Process Variable: Volume Flow Rate
- AO Cutoff: 15 l/sec
- Volume Flow Cutoff: 10 l/sec

Result:

- If the volume flow rate drops below 15 l/sec but not below 10 l/sec:
 - The mA output will report zero flow.
 - The frequency output will report the actual flow rate, and the actual flow rate will be used in all internal processing.
- If the volume flow rate drops below 10 l/sec, both outputs will report zero flow, and 0 will be used in all internal processing.

4.3 Configure gas standard volume (GSV) flow measurement

The gas standard volume (GSV) flow measurement parameters control how gas standard volume flow is measured and reported.

The GSV flow measurement parameters include:

- Volume Flow Type
- Standard Gas Density
- Gas Standard Volume Flow Measurement Unit
- Gas Standard Volume Flow Cutoff

Restriction

You cannot implement both liquid volume flow and gas standard volume flow at the same time. You must choose one or the other.

4.3.1 Configure Volume Flow Type for gas applications

Display	<i>Not available</i>
ProLink II	ProLink > Configuration > Flow > Vol Flow Type
ProLink III	Device Tools > Configuration > Process Measurement > Flow
Field Communicator	Configure > Manual Setup > Measurements > GSV > Volume Flow Type > Standard Gas Volume

Overview

Volume Flow Type controls whether liquid or gas standard volume flow measurement is used.

Restriction

If you are using the petroleum measurement application, you must set Volume Flow Type to Liquid. Gas standard volume measurement is incompatible with the petroleum measurement application.

Restriction

If you are using the concentration measurement application, you must set Volume Flow Type to Liquid. Gas standard volume measurement is incompatible with the concentration measurement application.

Procedure

Set Volume Flow Type to Gas Standard Volume.

4.3.2 Configure Standard Gas Density

Display	<i>Not available</i>
ProLink II	ProLink > Configuration > Flow > Std Gas Density
ProLink III	Device Tools > Configuration > Process Measurement > Flow
Field Communicator	Configure > Manual Setup > Measurements > GSV > Gas Ref Density

Overview

The Standard Gas Density value is used to convert the measured flow data to the standard reference values.

Prerequisites

Ensure that Density Measurement Unit is set to the measurement unit you want to use for Standard Gas Density.

Procedure

Set Standard Gas Density to the standard reference density of the gas you are measuring.

Note

ProLink II and ProLink III provide a guided method that you can use to calculate the standard density of your gas, if you do not know it.

4.3.3 Configure Gas Standard Volume Flow Measurement Unit

Display	OFF-LINE MAINT > OFF-LINE CONFIG > UNITS > GSV
ProLink II	ProLink > Configuration > Flow > Std Gas Vol Flow Units
ProLink III	Device Tools > Configuration > Process Measurement > Flow
Field Communicator	Configure > Manual Setup > Measurements > GSV > GSV Flow Unit

Overview

Gas Standard Volume Flow Measurement Unit specifies the unit of measure that will be displayed for the gas standard volume flow rate. The measurement unit used for the gas standard volume total and the gas standard volume inventory is derived from this unit.

Prerequisites

Before you configure Gas Standard Volume Flow Measurement Unit, be sure that Volume Flow Type is set to Gas Standard Volume.

Procedure

Set Gas Standard Volume Flow Measurement Unit to the unit you want to use.

The default setting for Gas Standard Volume Flow Measurement Unit is SCFM (Standard Cubic Feet per Minute).

Tip

If the measurement unit you want to use is not available, you can define a special measurement unit.

Options for Gas Standard Volume Flow Measurement Unit

The transmitter provides a standard set of measurement units for Gas Standard Volume Flow Measurement Unit, plus one user-defined special measurement unit. Different communications tools may use different labels for the units.

Table 4-4: Options for Gas Standard Volume Measurement Unit

Unit description	Label			
	Display	ProLink II	ProLink III	Field Communicator
Normal cubic meters per second	NM3/S	Nm3/sec	Nm3/sec	Nm3/sec
Normal cubic meters per minute	NM3/MN	Nm3/min	Nm3/sec	Nm3/min
Normal cubic meters per hour	NM3/H	Nm3/hr	Nm3/hr	Nm3/hr
Normal cubic meters per day	NM3/D	Nm3/day	Nm3/day	Nm3/day
Normal liter per second	NLPS	NLPS	NLPS	NLPS
Normal liter per minute	NLPM	NLPM	NLPM	NLPM
Normal liter per hour	NLPH	NLPH	NLPH	NLPH
Normal liter per day	NLPD	NLPD	NLPD	NLPD
Standard cubic feet per second	SCFS	SCFS	SCFS	SCFS
Standard cubic feet per minute	SCFM	SCFM	SCFM	SCFM
Standard cubic feet per hour	SCFH	SCFH	SCFH	SCFH
Standard cubic feet per day	SCFD	SCFD	SCFD	SCFD
Standard cubic meters per second	SM3/S	Sm3/S	Sm3/sec	Sm3/sec
Standard cubic meters per minute	SM3/MN	Sm3/min	Sm3/min	Sm3/min
Standard cubic meters per hour	SM3/H	Sm3/hr	Sm3/hr	Sm3/hr
Standard cubic meters per day	SM3/D	Sm3/day	Sm3/day	Sm3/day
Standard liter per second	SLPS	SLPS	SLPS	SLPS
Standard liter per minute	SLPM	SLPM	SLPM	SLPM
Standard liter per hour	SLPH	SLPH	SLPH	SLPH
Standard liter per day	SLPD	SLPD	SLPD	SLPD
Special measurement unit	SPECL	special	special	Special

Define a special measurement unit for gas standard volume flow

Display	<i>Not available</i>
ProLink II	ProLink > Configuration > Special Units
ProLink III	Device Tools > Configuration > Process Measurement > Flow > Special Units
Field Communicator	Configure > Manual Setup > Measurements > Special Units > Special GSV Units

Overview

A special measurement unit is a user-defined unit of measure that allows you to report process data, totalizer data, and inventory data in a unit that is not available in the transmitter. A special measurement unit is calculated from an existing measurement unit using a conversion factor.

Note

Although you cannot define a special measurement unit using the display, you can use the display to select an existing special measurement unit, and to view process data using the special measurement unit.

Procedure

1. Specify Base Gas Standard Volume Unit.

Base Gas Standard Volume Unit is the existing gas standard volume unit that the special unit will be based on.
2. Specify Base Time Unit.

Base Time Unit is the existing time unit that the special unit will be based on.
3. Calculate Gas Standard Volume Flow Conversion Factor as follows:
 - a. $x \text{ base units} = y \text{ special units}$
 - b. Gas Standard Volume Flow Conversion Factor = x/y
4. Enter the Gas Standard Volume Flow Conversion Factor.
5. Set Gas Standard Volume Flow Label to the name you want to use for the gas standard volume flow unit.
6. Set Gas Standard Volume Total Label to the name you want to use for the gas standard volume total and gas standard volume inventory unit.

The special measurement unit is stored in the transmitter. You can configure the transmitter to use the special measurement unit at any time.

Example: Defining a special measurement unit for gas standard volume flow

You want to measure gas standard volume flow in thousands of standard cubic feet per minute.

1. Set Base Gas Standard Volume Unit to SCFM.
2. Set Base Time Unit to minutes (min).
3. Calculate the conversion factor:
 - a. 1 thousands of standard cubic feet per minute = 1000 cubic feet per minute
 - b. Gas Standard Volume Flow Conversion Factor = $1/1000 = 0.001$
4. Set Gas Standard Volume Flow Conversion Factor to 0.001.
5. Set Gas Standard Volume Flow Label to KSCFM.
6. Set Gas Standard Volume Total Label to KSCF.

4.3.4 Configure Gas Standard Volume Flow Cutoff

Display	<i>Not available</i>
ProLink II	ProLink > Configuration > Flow > Std Gas Vol Flow Cutoff
ProLink III	Device Tools > Configuration > Process Measurement > Flow
Field Communicator	Configure > Manual Setup > Measurements > GSV > GSV Cutoff

Overview

Gas Standard Volume Flow Cutoff specifies the lowest gas standard volume flow rate that will be reported as measured. All gas standard volume flow rates below this cutoff will be reported as 0.

Procedure

Set Gas Standard Volume Flow Cutoff to the value you want to use.

The default value for Gas Standard Volume Flow Cutoff is 0.0. The lower limit is 0.0. There is no upper limit.

Interaction between Gas Standard Volume Flow Cutoff and AO Cutoff

Gas Standard Volume Flow Cutoff defines the lowest Gas Standard Volume flow value that the transmitter will report as measured. AO Cutoff defines the lowest flow rate that will be reported via the mA output. If mA Output Process Variable is set to Gas Standard Volume Flow Rate, the volume flow rate reported via the mA output is controlled by the higher of the two cutoff values.

Gas Standard Volume Flow Cutoff affects both the gas standard volume flow values reported via outputs and the gas standard volume flow values used in other transmitter behavior (e.g., events defined on gas standard volume flow).

AO Cutoff affects only flow values reported via the mA output.

Example: Cutoff interaction with AO Cutoff lower than Gas Standard Volume Flow Cutoff

Configuration:

- mA Output Process Variable for the primary mA output: Gas Standard Volume Flow Rate
- Frequency Output Process Variable: Gas Standard Volume Flow Rate
- AO Cutoff for the primary mA output: 10 SLPM (standard liters per minute)
- Gas Standard Volume Flow Cutoff: 15 SLPM

Result: If the gas standard volume flow rate drops below 15 SLPM, the volume flow will be reported as 0, and 0 will be used in all internal processing.

Example: Cutoff interaction with AO Cutoff higher than Gas Standard Volume Flow Cutoff

Configuration:

- mA Output Process Variable for the primary mA output: Gas Standard Volume Flow Rate
- Frequency Output Process Variable: Gas Standard Volume Flow Rate
- AO Cutoff for the primary mA output: 15 SLPM (standard liters per minute)
- Gas Standard Volume Flow Cutoff: 10 SLPM

Result:

- If the gas standard volume flow rate drops below 15 SLPM but not below 10 SLPM:
 - The primary mA output will report zero flow.
 - The frequency output will report the actual flow rate, and the actual flow rate will be used in all internal processing.
- If the gas standard volume flow rate drops below 10 SLPM, both outputs will report zero flow, and 0 will be used in all internal processing.

4.4 Configure Flow Direction

Display	<i>Not available</i>
ProLink II	ProLink > Configuration > Flow > Flow Direction
ProLink III	Device Tools > Configuration > Process Measurement > Flow
Field Communicator	Configure > Manual Setup > Measurements > Flow > Flow Direction

Overview

Flow Direction controls how forward flow and reverse flow affect flow measurement and reporting.

Flow Direction is defined with respect to the flow arrow on the sensor:

- Forward flow (positive flow) moves in the direction of the flow arrow on the sensor.
- Reverse flow (negative flow) moves in the direction opposite to the flow arrow on the sensor.

Tip

Micro Motion sensors are bidirectional. Measurement accuracy is not affected by actual flow direction or the setting of the Flow Direction parameter.

Procedure

Set Flow Direction to the value you want to use.

4.4.1 Options for Flow Direction

Table 4-5: Options for Flow Direction

Flow Direction setting			Relationship to Flow Direction arrow on sensor
ProLink II	ProLink III	Field Communicator	
Forward	Forward	Forward	Appropriate when the Flow Direction arrow is in the same direction as the majority of flow.
Reverse	Reverse	Reverse	Appropriate when the Flow Direction arrow is in the same direction as the majority of flow.
Absolute Value	Absolute Value	Absolute Value	Flow Direction arrow is not relevant.
Bidirectional	Bidirectional	Bi directional	Appropriate when both forward and reverse flow are expected, and forward flow will dominate, but the amount of reverse flow will be significant.
Negate Forward	Negate Forward	Negate/Forward Only	Appropriate when the Flow Direction arrow is in the opposite direction from the majority of flow.
Negate Bidirectional	Negate Bidirectional	Negate/Bi-directional	Appropriate when both forward and reverse flow are expected, and reverse flow will dominate, but the amount of forward flow will be significant.

Effect of Flow Direction on mA outputs

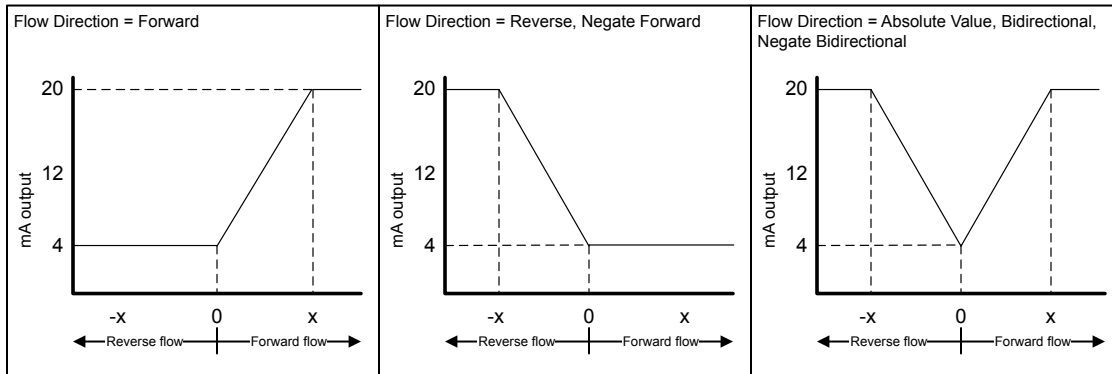
Flow Direction affects how the transmitter reports flow values via the mA outputs. The mA outputs are affected by Flow Direction only if mA Output Process Variable is set to a flow variable.

Flow Direction and mA outputs

The effect of Flow Direction on the mA outputs depend on Lower Range Value configured for the mA output:

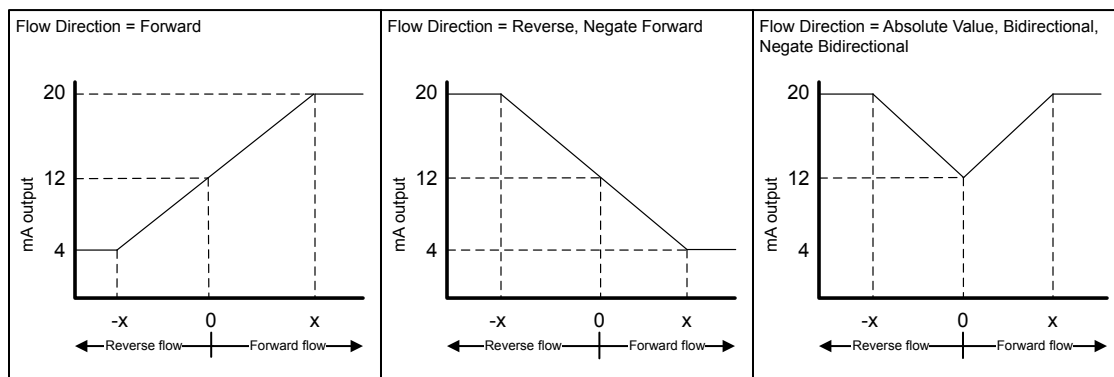
- If Lower Range Value is set to 0, see [Figure 4-1](#).
- If Lower Range Value is set to a negative value, see [Figure 4-2](#).

Figure 4-1: Effect of Flow Direction on the mA output: Lower Range Value = 0



- Lower Range Value = 0
- Upper Range Value = x

Figure 4-2: Effect of Flow Direction on the mA output: Lower Range Value < 0



- Lower Range Value = -x
- Upper Range Value = x

Example: Flow Direction = Forward and Lower Range Value = 0

Configuration:

- Flow Direction = Forward
- Lower Range Value = 0 g/sec
- Upper Range Value = 100 g/sec

Result:

- Under conditions of reverse flow or zero flow, the mA output is 4 mA.
- Under conditions of forward flow, up to a flow rate of 100 g/sec, the mA output varies between 4 mA and 20 mA in proportion to the flow rate.
- Under conditions of forward flow, if the flow rate equals or exceeds 100 g/sec, the mA output will be proportional to the flow rate up to 20.5 mA, and will be level at 20.5 mA at higher flow rates.

Example: Flow Direction = Forward and Lower Range Value < 0

Configuration:

- Flow Direction = Forward
- Lower Range Value = -100 g/sec
- Upper Range Value = +100 g/sec

Result:

- Under conditions of zero flow, the mA output is 12 mA.
- Under conditions of forward flow, for flow rates between 0 and +100 g/sec, the mA output varies between 12 mA and 20 mA in proportion to (the absolute value of) the flow rate.
- Under conditions of forward flow, if (the absolute value of) the flow rate equals or exceeds 100 g/sec, the mA output is proportional to the flow rate up to 20.5 mA, and will be level at 20.5 mA at higher flow rates.
- Under conditions of reverse flow, for flow rates between 0 and -100 g/sec, the mA output varies between 4 mA and 12 mA in inverse proportion to the absolute value of the flow rate.
- Under conditions of reverse flow, if the absolute value of the flow rate equals or exceeds 100 g/sec, the mA output is inversely proportional to the flow rate down to 3.8 mA, and will be level at 3.8 mA at higher absolute values.

Example: Flow Direction = Reverse

Configuration:

- Flow Direction = Reverse
- Lower Range Value = 0 g/sec
- Upper Range Value = 100 g/sec

Result:

- Under conditions of forward flow or zero flow, the mA output is 4 mA.
- Under conditions of reverse flow, for flow rates between 0 and +100 g/sec, the mA output level varies between 4 mA and 20 mA in proportion to the absolute value of the flow rate.
- Under conditions of reverse flow, if the absolute value of the flow rate equals or exceeds 100 g/sec, the mA output will be proportional to the absolute value of the flow rate up to 20.5 mA, and will be level at 20.5 mA at higher absolute values.

Effect of Flow Direction on frequency outputs

Flow Direction affects how the transmitter reports flow values via the frequency outputs. The frequency outputs are affected by Flow Direction only if Frequency Output Process Variable is set to a flow variable.

Table 4-6: Effect of the Flow Direction parameter and actual flow direction on frequency outputs

Flow Direction setting	Actual flow direction		
	Forward	Zero flow	Reverse
Forward	Hz > 0	0 Hz	0 Hz
Reverse	0 Hz	0 Hz	Hz > 0
Bidirectional	Hz > 0	0 Hz	Hz > 0
Absolute Value	Hz > 0	0 Hz	Hz > 0
Negate Forward	0 Hz	0 Hz	Hz > 0
Negate Bidirectional	Hz > 0	0 Hz	Hz > 0

Effect of Flow Direction on discrete outputs

The Flow Direction parameter affects the discrete output behavior only if Discrete Output Source is set to Flow Direction.

Table 4-7: Effect of the Flow Direction parameter and actual flow direction on discrete outputs

Flow Direction setting	Actual flow direction		
	Forward	Zero flow	Reverse
Forward	OFF	OFF	ON
Reverse	OFF	OFF	ON
Bidirectional	OFF	OFF	ON
Absolute Value	OFF	OFF	OFF
Negate Forward	ON	OFF	OFF
Negate Bidirectional	ON	OFF	OFF

Effect of Flow Direction on digital communications

Flow Direction affects how flow values are reported via digital communications.

Table 4-8: Effect of the Flow Direction parameter and actual flow direction on flow values reported via digital communications

Flow Direction setting	Actual flow direction		
	Forward	Zero flow	Reverse
Forward	Positive	0	Negative
Reverse	Positive	0	Negative
Bidirectional	Positive	0	Negative
Absolute Value	Positive ⁽³⁾	0	Positive
Negate Forward	Negative	0	Positive
Negate Bidirectional	Negative	0	Positive

Effect of Flow Direction on flow totals

Flow Direction affects how flow totals and inventories are calculated.

Table 4-9: Effect of the Flow Direction parameter and actual flow direction on flow totals and inventories

Flow Direction setting	Actual flow direction		
	Forward	Zero flow	Reverse
Forward	Totals increase	Totals do not change	Totals do not change
Reverse	Totals do not change	Totals do not change	Totals increase
Bidirectional	Totals increase	Totals do not change	Totals decrease
Absolute Value	Totals increase	Totals do not change	Totals increase
Negate Forward	Totals do not change	Totals do not change	Totals increase
Negate Bidirectional	Totals decrease	Totals do not change	Totals increase

4.5 Configure density measurement

The density measurement parameters control how density is measured and reported. Density measurement (along with mass measurement) is used to determine liquid volume flow.

The density measurement parameters include:

- Density Measurement Unit
- Slug Flow Parameters
- Density Damping
- Density Cutoff

(3) Refer to the digital communications status bits for an indication of whether flow is positive or negative.

4.5.1 Configure Density Measurement Unit

Display	OFF-LINE MAINT > OFF-LINE CONFIG > UNITS > DENS
ProLink II	ProLink > Configuration > Density > Density Units
ProLink III	Device Tools > Configuration > Process Measurement > Density
Field Communicator	Configure > Manual Setup > Measurements > Density > Density Unit

Overview

Density Measurement Unit specifies the units of measure that will be displayed for density measurement.

Procedure

Set Density Measurement Unit to the option you want to use.

The default setting for Density Measurement Unit is g/cm³ (grams per cubic centimeter).

Options for Density Measurement Unit

The transmitter provides a standard set of measurement units for Density Measurement Unit. Different communications tools may use different labels.

Table 4-10: Options for Density Measurement Unit

Unit description	Label			
	Display	ProLink II	ProLink III	Field Communicator
Specific gravity unit (not temperature-corrected)	SGU	SGU	SGU	SGU
Grams per cubic centimeter	G/CM3	g/cm3	g/cm3	g/Cucm
Grams per liter	G/L	g/l	g/l	g/L
Grams per milliliter	G/mL	g/ml	g/ml	g/mL
Kilograms per liter	KG/L	kg/l	kg/l	kg/L
Kilograms per cubic meter	KG/M3	kg/m3	kg/m3	kg/Cum
Pounds per U.S. gallon	LB/GAL	lbs/Usgal	lbs/Usgal	lb/gal
Pounds per cubic foot	LB/CUF	lbs/ft3	lbs/ft3	lb/Cuft
Pounds per cubic inch	LB/CUI	lbs/in3	lbs/in3	lb/Cuin
API gravity	D API	degAPI	degAPI	degAPI
Short ton per cubic yard	ST/CUY	sT/yd3	sT/yd3	STon/Cuyd

4.5.2 Configure slug flow parameters

Display	<i>Not available</i>
ProLink II	<ul style="list-style-type: none"> ProLink > Configuration > Density > Slug High Limit ProLink > Configuration > Density > Slug Low Limit ProLink > Configuration > Density > Slug Duration
ProLink III	Device Tools > Configuration > Process Measurement > Density
Field Communicator	<ul style="list-style-type: none"> Configure > Manual Setup > Measurements > Density > Slug Low Limit Configure > Manual Setup > Measurements > Density > Slug High Limit Configure > Manual Setup > Measurements > Density > Slug Duration

Overview

The slug flow parameters control how the transmitter detects and reports two-phase flow (gas in a liquid process or liquid in a gas process).

Procedure

1. Set Slug Low Limit to the lowest density value that is considered normal in your process.

Values below this will cause the transmitter to perform the configured slug flow action. Typically, this value is the lowest density value in the normal range of your process.

Tip

Gas entrainment can cause your process density to drop temporarily. To reduce the occurrence of slug flow alarms that are not significant to your process, set Slug Low Limit slightly below your expected lowest process density.

You must enter Slug Low Limit in g/cm^3 , even if you configured another unit for density measurement.

The default value for Slug Low Limit is $0.0 \text{ g}/\text{cm}^3$. The range is 0.0 to $10.0 \text{ g}/\text{cm}^3$.

2. Set Slug High Limit to the highest density value that is considered normal in your process.

Values above this will cause the transmitter to perform the configured slug flow action. Typically, this value is the highest density value in the normal range of your process.

Tip

To reduce the occurrence of slug flow alarms that are not significant to your process, set Slug High Limit slightly above your expected highest process density.

You must enter Slug High Limit in g/cm^3 , even if you configured another unit for density measurement.

The default value for Slug High Limit is 5.0 g/cm³. The range is 0.0 to 10.0 g/cm³.

3. Set Slug Duration to the number of seconds that the transmitter will wait for a slug flow condition to clear before performing the configured slug flow action.

The default value for Slug Duration is 0.0 seconds. The range is 0.0 to 60.0 seconds.

Slug flow detection and reporting

Slug flow is typically used as an indicator of two-phase flow (gas in a liquid process or liquid in a gas process). Two-phase flow can cause a variety of process control issues. By configuring the slug flow parameters appropriately for your application, you can detect process conditions that require correction.

Tip

To decrease the occurrence of slug flow alarms, lower Slug Low Limit or raise Slug High Limit.

A slug flow condition occurs whenever the measured density goes below Slug Low Limit or above Slug High Limit. If this occurs:

- A slug flow alarm is posted to the active alarm log.
- All outputs that are configured to represent flow rate hold their last “pre-slug flow” value for the configured Slug Duration.

If the slug flow condition clears before Slug Duration expires:

- Outputs that represent flow rate revert to reporting actual flow.
- The slug flow alarm is deactivated, but remains in the active alarm log until it is acknowledged.

If the slug flow condition does not clear before Slug Duration expires, the outputs that represent flow rate report a flow rate of 0.

If Slug Duration is set to 0.0 seconds, the outputs that represent flow rate will report a flow rate of 0 as soon as slug flow is detected.

4.5.3 Configure Density Damping

Display	<i>Not available</i>
ProLink II	ProLink > Configuration > Density > Density Damping
ProLink III	Device Tools > Configuration > Process Measurement > Density
Field Communicator	Configure > Manual Setup > Measurements > Density > Density Damping

Overview

Damping is used to smooth out small, rapid fluctuations in process measurement. Damping Value specifies the time period (in seconds) over which the transmitter will spread changes in the reported process variable. At the end of the interval, the reported process variable will reflect 63% of the change in the actual measured value.

Procedure

Set Density Damping to the value you want to use.

The default value is 1.6 seconds. The range depends on the core processor type and the setting of Update Rate, as shown in the following table:

Core processor type	Update Rate setting	Density Damping range
Standard	Normal	0 to 51.2 seconds
	Special	0 to 10.24 seconds
Enhanced	Not applicable	0 to 40.96 seconds

Tips

- A high damping value makes the process variable appear smoother because the reported value changes slowly.
- A low damping value makes the process variable appear more erratic because the reported value changes more quickly.
- Whenever the damping value is non-zero, the reported measurement will lag the actual measurement because the reported value is being averaged over time.
- In general, lower damping values are preferable because there is less chance of data loss, and less lag time between the actual measurement and the reported value.

The value you enter is automatically rounded down to the nearest valid value. The valid values for Density Damping depend on the setting of Update Rate.

Table 4-11: Valid values for Density Damping

Core processor type	Update Rate setting	Valid damping values
Standard	Normal	0, 0.2, 0.4, 0.8, ... 51.2
	Special	0, 0.04, 0.08, 0.16, ... 10.24
Enhanced	Not applicable	0, 0.04, 0.08, 0.16, ... 40.96

Effect of Density Damping on volume measurement

Density Damping affects liquid volume measurement. Liquid volume values are calculated from the damped density value rather than the measured density value. Density Damping does not affect gas standard volume measurement.

Interaction between Density Damping and Added Damping

In some circumstances, both Density Damping and Added Damping are applied to the reported density value.

Density Damping controls the rate of change in the density process variable. Added Damping controls the rate of change reported via the mA output. If mA Output Process Variable is set to Density, and both Density Damping and Added Damping are set to non-zero values, density damping is applied first, and the added damping calculation is applied to the result of the first calculation.

4.5.4 Configure Density Cutoff

Display	<i>Not available</i>
ProLink II	ProLink > Configuration > Density > Low Density Cutoff
ProLink III	Device Tools > Configuration > Process Measurement > Density
Field Communicator	Configure > Manual Setup > Measurements > Density > Density Cutoff

Overview

Density Cutoff specifies the lowest density value that will be reported as measured. All density values below this cutoff will be reported as 0.

Procedure

Set Density Cutoff to the value you want to use.

The default value for Density Cutoff is 0.2 g/cm³. The range is 0.0 g/cm³ to 0.5 g/cm³.

Effect of Density Cutoff on volume measurement

Density Cutoff affects liquid volume measurement. If the density value goes below Density Cutoff, the volume flow rate is reported as 0. Density Cutoff does not affect gas standard volume measurement. Gas standard volume values are always calculated from the value configured for Standard Gas Density.

4.6 Configure temperature measurement

The temperature measurement parameters control how temperature data from the sensor is reported. Temperature data is used to compensate for the effect of temperature on the sensor tubes during flow measurement.

The temperature measurement parameters include:

- Temperature Measurement Unit
- Temperature Damping

4.6.1 Configure Temperature Measurement Unit

Display	OFF-LINE MAINT > OFF-LINE CONFIG > UNITS > TEMP
ProLink II	ProLink > Configuration > Temperature > Temp Units
ProLink III	Device Tools > Configuration > Process Measurement > Temperature
Field Communicator	Configure > Manual Setup > Measurements > Temperature > Temperature Unit

Overview

Temperature Measurement Unit specifies the unit that will be used for temperature measurement.

Procedure

Set Temperature Measurement Unit to the option you want to use.

The default setting is Degrees Celsius.

Options for Temperature Measurement Unit

The transmitter provides a standard set of units for Temperature Measurement Unit. Different communications tools may use different labels for the units.

Table 4-12: Options for Temperature Measurement Unit

Unit description	Label			
	Display	ProLink II	ProLink III	Field Communicator
Degrees Celsius	°C	degC	°C	degC
Degrees Fahrenheit	°F	degF	°F	degF
Degrees Rankine	°R	degR	°R	degR
Kelvin	°K	degK	°K	Kelvin

4.6.2 Configure Temperature Damping

Display	<i>Not available</i>
ProLink II	ProLink > Configuration > Temperature > Temp Damping
ProLink III	Device Tools > Configuration > Temperature
Field Communicator	Configure > Manual Setup > Measurements > Temperature > Temp Damping

Overview

Damping is used to smooth out small, rapid fluctuations in process measurement. Damping Value specifies the time period (in seconds) over which the transmitter will spread changes in the reported process variable. At the end of the interval, the reported process variable will reflect 63% of the change in the actual measured value.

Procedure

Enter the value you want to use for Temperature Damping.

The default value is 4.8 seconds. The range is 0.0 to 76.8 seconds.

Tips

- A high damping value makes the process variable appear smoother because the reported value changes slowly.
- A low damping value makes the process variable appear more erratic because the reported value changes more quickly.
- Whenever the damping value is non-zero, the reported measurement will lag the actual measurement because the reported value is being averaged over time.
- In general, lower damping values are preferable because there is less chance of data loss, and less lag time between the actual measurement and the reported value.

The value you enter is automatically rounded down to the nearest valid value. Valid values for Temperature Damping are 0, 0.6, 1.2, 2.4, 4.8, ... 76.8.

Effect of Temperature Damping on process measurement

Temperature Damping affects the response speed for temperature compensation with fluctuating temperatures. Temperature compensation adjusts the process measurement to compensate for the effect of temperature on the sensor tube.

Temperature Damping affects petroleum measurement process variables only if the transmitter is configured to use temperature data from the sensor. If an external temperature value is used for petroleum measurement, Temperature Damping does not affect petroleum measurement process variables.

Temperature Damping affects concentration measurement process variables only if the transmitter is configured to use temperature data from the sensor. If an external temperature value is used for concentration measurement, Temperature Damping does not affect concentration measurement process variables.

4.7 Configure the petroleum measurement application

The petroleum measurement application enables Correction for the effect of Temperature on the volume of Liquids (CTL), by calculating and applying a Volume Correction Factor (VCF) to volume measurement. Internal calculations are performed in compliance with American Petroleum Institute (API) standards.

4.7.1 Configure petroleum measurement using ProLink II

1. Choose ProLink > Configuration > API Setup.
2. Specify the API table to use.
 - a. In API Chapter 11.1 Table Type, select the API table group.
 - b. In Units, select the the measurement units you want to use.

These two parameters uniquely specify the API table.

3. If your API table is 53A, 53B, 53D, or 54C, set Reference Temperature to the appropriate value for your application. Enter the value in °C.
4. If your API table is 6C, 24C, or 54C, set Thermal Expansion Coefficient to the appropriate value for your application.
5. Determine how the transmitter will obtain temperature data for the petroleum measurement calculations, and perform the required setup.

Option	Setup
Temperature data from the sensor	<ol style="list-style-type: none"> a. Choose View > Preferences . b. Disable Use External Temperature.
A user-configured static temperature value	<ol style="list-style-type: none"> a. Choose View > Preferences . b. Enable Use External Temperature. c. Choose ProLink > Configuration > Temperature. d. Set External Temperature to the value to be used.

Option	Setup
Polling for temperature	<ol style="list-style-type: none"> a. Ensure that the primary mA output has been wired to support HART polling. b. Choose View > Preferences . c. Enable Use External Temperature. d. Choose ProLink > Configuration > Polled Variables. e. Choose an unused polling slot. f. Set Polling Control to Poll As Primary or Poll as Secondary, and click Apply. g. Set External Tag to the HART tag of the external temperature device. h. Set Variable Type to External Temperature. <hr/> <p>Tip</p> <ul style="list-style-type: none"> • Poll as Primary: No other HART masters will be on the network. • Poll as Secondary: Other HART masters will be on the network. The Field Communicator is not a HART master.
A value written by digital communications	<ol style="list-style-type: none"> a. Choose View > Preferences . b. Enable Use External Temperature. c. Perform the necessary host programming and communications setup to write temperature data to the transmitter at appropriate intervals. <hr/> <p>Note</p> <p>If the Weights & Measures application is implemented and the transmitter is secured, digital communications cannot be used to write temperature data to the transmitter.</p>

4.7.2 Configure petroleum measurement using ProLink III

1. Choose Device Tools > Configuration > Process Measurement > Petroleum Measurement.
2. Specify the API table to use.
 - a. Select the API table group from API Table Type.
 - b. Set Petroleum Measurement Units to the measurement units you want to use.
 - c. Click Apply.

These two parameters uniquely specify the API table.

3. If your API table is 53A, 53B, 53D, or 54C, set Reference Temperature to the appropriate value for your application. Enter the value in °C.
4. If your API table is 6C, 24C, or 54C, set Thermal Expansion Coefficient to the appropriate value for your application.

5. Set Temperature Source to the method that the transmitter will use to obtain temperature data.

Option	Description
Poll for external value	The transmitter will poll an external temperature device, using HART protocol over the primary mA output.
RTD	The transmitter will use the temperature data from the sensor.
Static or Digital Communications	The transmitter will use the temperature value that it reads from memory. <ul style="list-style-type: none"> • Static: The configured value is used. • Digital Communications: An external host writes transmitter data to transmitter memory. The same location in memory is used for both options.

External temperature data is used only in petroleum measurement calculations. All other transmitter calculations use temperature data from the sensor.

6. If you chose RTD, no more configuration is required. Click Apply and exit.
7. If you chose to poll for temperature data:
- a. Select the Polling Slot to use.

The transmitter has two polling slots. You can use one for temperature and the other for pressure, if pressure compensation is enabled.

- b. Set Polling Control to Poll as Primary or Poll as Secondary, and click Apply.

Tip

- Poll as Primary: No other HART masters will be on the network.
 - Poll as Secondary: Other HART masters will be on the network. The Field Communicator is not a HART master.
-

- c. Set External Device Tag to the HART tag of the external temperature device, and click Apply.
8. If you chose to use a static temperature value, set External Temperature to the value to use, and click Apply.
9. If you want to use digital communications, perform the necessary host programming and communications setup to write temperature data to the transmitter at appropriate intervals.

Note

If the Weights & Measures application is implemented and the transmitter is secured, digital communications cannot be used to write temperature data to the transmitter.

4.7.3 Configure petroleum measurement using the Field Communicator

1. Choose Online > Configure > Manual Setup > Measurements > Set Up Petroleum.
2. Specify the API table to use.
 - a. Open the Petroleum Measurement Source menu and select the API table number.

Depending on your choice, you may be prompted to enter a reference temperature or a thermal expansion coefficient.

- b. Enter the API table letter.

These two parameters uniquely specify the API table.

3. Determine how the transmitter will obtain temperature data for the petroleum measurement calculations, and perform the required setup.

Option	Setup
Temperature data from the sensor	<ol style="list-style-type: none"> a. Choose Online > Configure > Manual Setup > Measurements > External Pressure/Temperature > Temperature. b. Set External Temperature to Disabled.
A user-configured static temperature value	<ol style="list-style-type: none"> a. Choose Online > Configure > Manual Setup > Measurements > External Pressure/Temperature > Temperature. b. Set External Temperature to Enabled. c. Set Correction Temperature to the value to be used.
Polling for temperature	<ol style="list-style-type: none"> a. Ensure that the primary mA output has been wired to support HART polling. b. Choose Online > Configure > Manual Setup > Measurements > External Pressure/Temperature > Temperature. c. Set External Temperature to Enabled. d. Choose External Polling. e. Set Poll Control to Poll As Primary or Poll as Secondary. f. Determine whether you will use Polling Slot 1 or Polling Slot 2. g. For the chosen slot, set Ext Dev Tag to the HART tag of the external temperature device. h. For the chosen slot, set Polled Variable to Temperature. <hr/> <p>Tip</p> <ul style="list-style-type: none"> • Poll as Primary: No other HART masters will be on the network. • Poll as Secondary: Other HART masters will be on the network. The Field Communicator is not a HART master. <hr/>

Option	Setup
A value written by digital communications	<ol style="list-style-type: none"> Choose Online > Configure > Manual Setup > Measurements > External Pressure/Temperature > Temperature. Set External Temperature to Enabled. Perform the necessary host programming and communications setup to write temperature data to the transmitter at appropriate intervals.
	<p>Note</p> <p>If the Weights & Measures application is implemented and the transmitter is secured, digital communications cannot be used to write temperature data to the transmitter.</p>

4.7.4 API reference tables

Table 4-13: API reference tables, associated process fluids, and associated calculation values

Table name	Process fluid	CTL source data	Reference temperature	Density unit
5A	Generalized crude and JP4	Observed density and observed temperature	60 °F (non-configurable)	Degrees API Range: 0 to 100
5B	Generalized products	Observed density and observed temperature	60 °F (non-configurable)	Degrees API Range: 0 to 85
5D	Lubricating oils	Observed density and observed temperature	60 °F (non-configurable)	Degrees API Range: -10 to +40
6C	Liquids with a constant density base or known thermal expansion coefficient	User-supplied reference density (or thermal expansion coefficient) and observed temperature	60 °F (non-configurable)	Degrees API
23A	Generalized crude and JP4	Observed density and observed temperature	60 °F (non-configurable)	Relative density Range: 0.6110 to 1.0760
23B	Generalized products	Observed density and observed temperature	60 °F (non-configurable)	Relative density Range: 0.6535 to 1.0760
23D	Lubricating oils	Observed density and observed temperature	60 °F (non-configurable)	Relative density Range: 0.8520 to 1.1640
24C	Liquids with a constant density base or known thermal expansion coefficient	User-supplied reference density (or thermal expansion coefficient) and observed temperature	60 °F (non-configurable)	Relative density
53A	Generalized crude and JP4	Observed density and observed temperature	15 °C (configurable)	Base density Range: 610 to 1075 kg/m ³

Table 4-13: API reference tables, associated process fluids, and associated calculation values (continued)

Table name	Process fluid	CTL source data	Reference temperature	Density unit
53B	Generalized products	Observed density and observed temperature	15 °C (configurable)	Base density Range: 653 to 1075 kg/m ³
53D	Lubricating oils	Observed density and observed temperature	15 °C (configurable)	Base density Range: 825 to 1164 kg/m ³
54C	Liquids with a constant density base or known thermal expansion coefficient	User-supplied reference density (or thermal expansion coefficient) and observed temperature	15 °C (configurable)	Base density in kg/m ³

4.8 Configure the concentration measurement application

The concentration measurement application calculates concentration data from process temperature and density. Micro Motion provides a set of concentration matrices that provide the reference data for several standard industry applications and process fluids. If desired, you can build a custom matrix for your process fluid, or purchase a custom matrix from Micro Motion.

More information about the concentration measurement application is available in the following manual: *Micro Motion Enhanced Density Application: Theory, Configuration, and Use*.

Note

The concentration measurement application is also known as the enhanced density application.

4.8.1 Configure concentration measurement using ProLink II

This task guides you through loading and setting up a concentration matrix to use for measurement. It does not cover building a concentration matrix.

Note

Concentration matrices can be made available on your transmitter either by loading an existing matrix from a file or by building a new matrix. Up to six matrices can be available on your transmitter, but only one can be used for measurement at any given time. See *Micro Motion Enhanced Density Application: Theory, Configuration, and Use* for detailed information on building a matrix.

Prerequisites

Before you can configure concentration measurement:

- The concentration measurement application must be enabled on your transmitter.
- The concentration matrix you want to use must be available on your transmitter, or it must be available as a file on your computer.
- You must know the derived variable that your matrix is designed for.
- You must know the density unit used by your matrix.
- You must know the temperature unit used by your matrix.
- The concentration measurement application must be unlocked.

Procedure

1. Choose ProLink > Configuration > Density and set Density Units to the density unit used by your matrix.
2. Choose ProLink > Configuration > Temperature and set Temp Units to the temperature unit used by your matrix.
3. Choose ProLink > Configuration > CM Setup.
4. In Global Config, set Derived Variable to the derived variable that your matrix is designed for.

Important

- All concentration matrices on your transmitter must use the same derived variable. If you are using one of the standard matrices from Micro Motion, set Derived Variable to Mass Conc (Density). If you are using a custom matrix, see the reference information for your matrix.
 - If you change the setting of Derived Variable, all existing concentration matrices will be deleted from transmitter memory. Set Derived Variable before loading concentration matrices.
-

5. Load one or more matrices.
 - a. In Curve Specific Config, set Curve Configured to the location to which the matrix will be loaded.
 - b. Click Load this curve from a file, navigate to the matrix file on your PC, and load it.
 - c. Repeat until all required matrices are loaded.
6. Set up extrapolation alarms.

Each concentration matrix is built for a specific density range and a specific temperature range. If process density or process temperature goes outside the range, the transmitter will extrapolate concentration values. However, extrapolation may affect accuracy. Extrapolation alarms are used to notify the operator that extrapolation is occurring.

- a. In Curve Specific Config, set Curve Configured to the matrix that you want to configure.
- b. Set Alarm Limit to the point, in percent, at which an extrapolation alarm will be posted.
- c. Enable or disable the high and low limit alarms for temperature and density, as desired.

Restriction

The high and low limit alarms require the enhanced core processor.

Example: If Alarm Limit is set to 5%, Enable Temp High is checked, and the matrix is built for a temperature range of 40 °F to 80 °F, an extrapolation alarm will be posted if process temperature goes above 82 °F

7. Select the label that will be used for the concentration unit.
 - a. In Curve Specific Config, set Curve Configured to the matrix that you want to configure.
 - b. Select the desired label from the Units list.
 - c. If you set Units to Special, enter the custom label.
8. Determine how the transmitter will obtain temperature data for the concentration measurement calculations, and perform the required setup.

Option	Setup
Temperature data from the sensor	<ol style="list-style-type: none"> a. Choose View > Preferences . b. Disable Use External Temperature.
A user-configured static temperature value	<ol style="list-style-type: none"> a. Choose View > Preferences . b. Enable Use External Temperature. c. Choose ProLink > Configuration > Temperature. d. Set External Temperature to the value to be used.
Polling for temperature	<ol style="list-style-type: none"> a. Ensure that the primary mA output has been wired to support HART polling. b. Choose View > Preferences . c. Enable Use External Temperature. d. Choose ProLink > Configuration > Polled Variables. e. Choose an unused polling slot. f. Set Polling Control to Poll As Primary or Poll as Secondary, and click Apply. g. Set External Tag to the HART tag of the external temperature device. h. Set Variable Type to External Temperature. <hr/> <p>Tip</p> <ul style="list-style-type: none"> • Poll as Primary: No other HART masters will be on the network. • Poll as Secondary: Other HART masters will be on the network. The Field Communicator is not a HART master. <hr/>

Option	Setup
A value written by digital communications	<ol style="list-style-type: none"> a. Choose View > Preferences . b. Enable Use External Temperature. c. Perform the necessary host programming and communications setup to write temperature data to the transmitter at appropriate intervals. <hr/> <p>Note If the Weights & Measures application is implemented and the transmitter is secured, digital communications cannot be used to write temperature data to the transmitter.</p> <hr/>

9. In Global Config, set Active Curve to the matrix to be used for process measurement.

Concentration process variables are now available on the transmitter. You can view and report them in the same way that you view and report other process variables.

4.8.2 Configure concentration measurement using ProLink III

This task guides you through loading and setting up a concentration matrix to use for measurement. It does not cover building a concentration matrix.

Note

Concentration matrices can be made available on your transmitter either by loading an existing matrix from a file or by building a new matrix. Up to six matrices can be available on your transmitter, but only one can be used for measurement at any given time. See *Micro Motion Enhanced Density Application: Theory, Configuration, and Use* for detailed information on building a matrix.

Prerequisites

Before you can configure concentration measurement:

- The concentration measurement application must be enabled on your transmitter.
- The concentration matrix you want to use must be available on your transmitter, or it must be available as a file on your computer.
- You must know the derived variable that your matrix is designed for.
- You must know the density unit used by your matrix.
- You must know the temperature unit used by your matrix.
- The concentration measurement application must be unlocked.

Procedure

1. Choose Device Tools > Configuration > Process Measurement > Density and set Density Unit to the density unit used by your matrix.
2. Choose Device Tools > Configuration > Process Measurement > Temperature and set Temperature Unit to the temperature unit used by your matrix.

3. Choose Device Tools > Configuration > Process Measurement > Concentration Measurement.
4. Set Derived Variable to the derived variable that your matrix is designed for, and click Apply.

Important

- All concentration matrices on your transmitter must use the same derived variable. If you are using one of the standard matrices from Micro Motion, set Derived Variable to Mass Concentration (Density). If you are using a custom matrix, see the reference information for your matrix.
 - If you change the setting of Derived Variable, all existing concentration matrices will be deleted from transmitter memory. Set Derived Variable before loading concentration matrices.
-

5. Load one or more matrices.
 - a. Set Matrix Being Configured to the location to which the matrix will be loaded.
 - b. Click Load Matrix from a File, navigate to the matrix file on your computer, and load it.
 - c. Repeat until all required matrices are loaded.
6. Review and configure matrix data.
 - a. If necessary, set Matrix Being Configured to the matrix you want to view, and click Change Matrix.
 - b. Set Concentration Unit to the label that will be used for the concentration unit.
 - c. If you set Concentration Unit to Special, enter the custom label.
 - d. If desired, change the matrix name.
 - e. Review the data points for this matrix.
 - f. Do not change Reference Temperature or Curve Fit Maximum Order.
 - g. If you changed any matrix data, click Apply.
7. Set up extrapolation alarms.

Each concentration matrix is built for a specific density range and a specific temperature range. If process density or process temperature goes outside the range, the transmitter will extrapolate concentration values. However, extrapolation may affect accuracy. Extrapolation alarms are used to notify the operator that extrapolation is occurring.

- a. If necessary, set Matrix Being Configured to the matrix you want to view, and click Change Matrix.
- b. Set Extrapolation Alarm Limit to the point, in percent, at which an extrapolation alarm will be posted.
- c. Enable or disable the high and low limit alarms for temperature and density, as desired, and click Apply.

Restriction

The high and low limit alarms require the enhanced core processor.

Example: If Extrapolation Alarm Limit is set to 5%, High Extrapolation Limit (Temperature) is enabled, and the matrix is built for a temperature range of 40 °F to 80 °F, an extrapolation alarm will be posted if process temperature goes above 82 °F

8. Set Temperature Source to the method that the transmitter will use to obtain temperature data.

Option	Description
Poll for external value	The transmitter will poll an external temperature device, using HART protocol over the primary mA output.
RTD	The transmitter will use the temperature data from the sensor.
Static or Digital Communications	<p>The transmitter will use the temperature value that it reads from memory.</p> <ul style="list-style-type: none"> • Static: The configured value is used. • Digital Communications: A host writes transmitter data to transmitter memory. <hr/> <p>Note</p> <p>If the Weights & Measures application is implemented and the transmitter is secured, digital communications cannot be used to write temperature data to the transmitter.</p>

9. If you chose RTD, no more configuration is required. Click Apply and exit.
10. If you chose to poll for temperature data:
 - a. Select the Polling Slot to use.
 - b. Set Polling Control to Poll as Primary or Poll as Secondary, and click Apply.

Tip

- Poll as Primary: No other HART masters will be on the network.
- Poll as Secondary: Other HART masters will be on the network. The Field Communicator is not a HART master.

- c. Set External Device Tag to the HART tag of the external temperature device, and click Apply.
11. If you chose to use a static temperature value, set External Temperature to the value to use, and click Apply.
12. If you want to use digital communications, click Apply, then perform the necessary host programming and communications setup to write temperature data to the transmitter at appropriate intervals.

13. Set Active Matrix to the matrix to be used for measurement.

Concentration process variables are now available on the transmitter. You can view and report them in the same way that you view and report other process variables.

4.8.3 Configure concentration measurement using the Field Communicator

This task guides you through setting up a concentration matrix to use for measurement. It does not cover loading or building a concentration matrix.

Note

Concentration matrices can be made available on your transmitter either by loading an existing matrix from a file or by building a new matrix. Up to six matrices can be available on your transmitter, but only one can be used for measurement at any given time. See *Micro Motion Enhanced Density Application: Theory, Configuration, and Use* for detailed information on building a matrix.

Prerequisites

Before you can configure concentration measurement:

- The concentration measurement application must be enabled on your transmitter.
- You must know the derived variable that your matrix is designed for.
- You must know the density unit used by your matrix.
- You must know the temperature unit used by your matrix.
- The concentration measurement application must be unlocked.

Procedure

1. Choose Online > Configure > Manual Setup > Measurements > Density and set Density Unit to match the density unit used by your matrix.
2. Choose Online > Configure > Manual Setup > Measurements > Temperature and set Temperature Unit to match the temperature unit used by your matrix.
3. Choose Online > Configure > Manual Setup > Measurements > Conc Measurement (CM) > CM Configuration.
4. Set up extrapolation alerts.

Each concentration matrix is built for a specific density range and a specific temperature range. If process density or process temperature goes outside the range, the transmitter will extrapolate concentration values. However, extrapolation may affect accuracy. Extrapolation alerts are used to notify the operator that extrapolation is occurring.

- a. Choose Online > Configure > Manual Setup > Measurements > Conc Measurement (CM) > Matrix Configuration.
- b. Set Matrix Being Configured to the matrix that you want to configure.
- c. Set Extrapolation Alert Limit to the point, in percent, at which an extrapolation alert will be posted.

- d. Choose Online > Configure > Alert Setup > CM Alerts.
- e. Enable or disable the high and low limit alarms for temperature and density, as desired.

Restriction

The high and low limit alarms require the enhanced core processor.

Example: If Alarm Limit is set to 5%, the high-temperature extrapolation alert is enabled, and the matrix is built for a temperature range of 40 °F to 80 °F, an extrapolation alarm will be posted if process temperature goes above 82 °F

5. Select the label that will be used for the concentration unit.
 - a. Choose Online > Configure > Manual Setup > Measurements > Conc Measurement (CM) > Matrix Configuration.
 - b. Set Matrix Being Configured to the matrix that you want to configure.
 - c. Set Concentration Units to the desired label.
 - d. If you set Units to Special, enter the custom label.
6. Determine how the transmitter will obtain temperature data for the concentration measurement calculations, and perform the required setup.

Option	Setup
Temperature data from the sensor	<ol style="list-style-type: none"> a. Choose Online > Configure > Manual Setup > Measurements > External Pressure/Temperature > Temperature. b. Disable External Temperature.
A user-configured static temperature value	<ol style="list-style-type: none"> a. Choose Online > Configure > Manual Setup > Measurements > External Pressure/Temperature > Temperature. b. Enable External Temperature. c. Set Correction Temperature to the value to be used.

Option	Setup
Polling for temperature	<ol style="list-style-type: none"> Ensure that the primary mA output has been wired to support HART polling. Choose Online > Configure > Manual Setup > Measurements > External Pressure/Temperature > Temperature. Enable External Temperature. Choose Online > Configure > Manual Setup > Measurements > External Pressure/Temperature > External Polling. Set Poll Control to Poll As Primary Host or Poll as Secondary Host. Choose an unused polling slot. Set External Tag to the HART tag of the external temperature device. Set Polled Variable to Temperature. <hr/> <p>Tip</p> <ul style="list-style-type: none"> Poll as Primary: No other HART masters will be on the network. Poll as Secondary: Other HART masters will be on the network. The Field Communicator is not a HART master.
A value written by digital communications	<ol style="list-style-type: none"> Choose Online > Configure > Manual Setup > Measurements > External Pressure/Temperature > Temperature. Enable External Temperature. Perform the necessary host programming and communications setup to write temperature data to the transmitter at appropriate intervals. <hr/> <p>Note</p> <p>If the Weights & Measures application is implemented and the transmitter is secured, digital communications cannot be used to write temperature data to the transmitter.</p>

- Online > Configure > Manual Setup > Measurements > Conc Measurement (CM) > CM Configuration and set Active Matrix to the matrix to be used for measurement.

Concentration process variables are now available on the transmitter. You can view and report them in the same way that you view and report other process variables.

4.8.4 Standard matrices for the concentration measurement application

The standard concentration matrices available from Micro Motion are applicable for a variety of process fluids.

See [Table 4-14](#) for a list of the standard concentration matrices available from Micro Motion, along with the density and temperature measurement units used in calculation, and the unit used to report concentration data.

Tip

If the standard matrices are not appropriate for your application, you can build a custom matrix or purchase a custom matrix from Micro Motion.

Table 4-14: Standard concentration matrices and associated measurement units

Matrix name	Description	Density unit	Temperature unit	Concentration unit
Deg Balling	Matrix represents percent extract, by mass, in solution, based on °Balling. For example, if a wort is 10 °Balling and the extract in solution is 100% sucrose, the extract is 10% of the total mass.	g/cm ³	°F	°Balling
Deg Brix	Matrix represents a hydrometer scale for sucrose solutions that indicates the percent by mass of sucrose in solution at a given temperature. For example, 40 kg of sucrose mixed with 60 kg of water results in a 40 °Brix solution.	g/cm ³	°C	°Brix
Deg Plato	Matrix represents percent extract, by mass, in solution, based on °Plato. For example, if a wort is 10 °Plato and the extract in solution is 100% sucrose, the extract is 10% of the total mass.	g/cm ³	°F	°Plato
HFCS 42	Matrix represents a hydrometer scale for HFCS 42 (high-fructose corn syrup) solutions that indicates the percent by mass of HFCS in solution.	g/cm ³	°C	%
HFCS 55	Matrix represents a hydrometer scale for HFCS 55 (high-fructose corn syrup) solutions that indicates the percent by mass of HFCS in solution.	g/cm ³	°C	%
HFCS 90	Matrix represents a hydrometer scale for HFCS 90 (high-fructose corn syrup) solutions that indicates the percent by mass of HFCS in solution.	g/cm ³	°C	%

4.8.5 Derived variables and calculated process variables

For each derived variable, the concentration measurement application calculates a different set of process variables.

Table 4-15: Derived variables and calculated process variables

Derived Variable	Description	Calculated process variables					
		Density at reference temperature	Standard volume flow rate	Specific gravity	Concentration	Net mass flow rate	Net volume flow rate
Density at reference temperature	Mass/unit volume, corrected to a given reference temperature	✓	✓				
Specific gravity	The ratio of the density of a process fluid at a given temperature to the density of water at a given temperature. The two given temperature conditions do not need to be the same.	✓	✓	✓			
Mass concentration derived from reference density	The percent mass of solute or of material in suspension in the total solution, derived from reference density	✓	✓		✓	✓	
Mass concentration derived from specific gravity	The percent mass of solute or of material in suspension in the total solution, derived from specific gravity	✓	✓	✓	✓	✓	
Volume concentration derived from reference density	The percent volume of solute or of material in suspension in the total solution, derived from reference density	✓	✓		✓		✓
Volume concentration derived from specific gravity	The percent volume of solute or of material in suspension in the total solution, derived from specific gravity	✓	✓	✓	✓		✓
Concentration derived from reference density	The mass, volume, weight, or number of moles of solute or of material in suspension in proportion to the total solution, derived from reference density	✓	✓		✓		

Table 4-15: Derived variables and calculated process variables (continued)

Derived Variable	Description	Calculated process variables					
		Density at reference temperature	Standard volume flow rate	Specific gravity	Concentration	Net mass flow rate	Net volume flow rate
Concentration derived from specific gravity	The mass, volume, weight, or number of moles of solute or of material in suspension in proportion to the total solution, derived from specific gravity	✓	✓	✓	✓		

4.9 Configure pressure compensation

Pressure compensation adjusts process measurement to compensate for the pressure effect on the sensor. The pressure effect is the change in the sensor's sensitivity to flow and density caused by the difference between the calibration pressure and the process pressure.

Tip

Not all sensors or applications require pressure compensation. The pressure effect for a specific sensor model can be found in the product data sheet located at www.micromotion.com. If you are uncertain about implementing pressure compensation, contact Micro Motion customer service.

4.9.1 Configure pressure compensation using ProLink II

Prerequisites

You will need the flow factor, density factor, and calibration pressure values for your sensor.

- For the flow factor and density factor, see the product data sheet for your sensor.
- For the calibration pressure, see the calibration sheet for your sensor. If the data is unavailable, use 20 PSI.

Procedure

1. Choose View > Preferences and ensure that Enable External Pressure Compensation is checked.
2. Choose ProLink > Configuration > Pressure.
3. Enter Flow Factor for your sensor.

The flow factor is the percent change in the flow rate per PSI. When entering the value, reverse the sign.

Example:

If the flow factor is 0.000004 % per PSI, enter -0.000004 % per PSI.

4. Enter Density Factor for your sensor.

The density factor is the change in fluid density, in g/cm³/PSI. When entering the value, reverse the sign.

Example:

If the density factor is 0.000006 g/cm³/PSI, enter -0.000006 g/cm³/PSI.

5. Enter Cal Pressure for your sensor.

The calibration pressure is the pressure at which your sensor was calibrated, and defines the pressure at which there is no pressure effect. If the data is unavailable, enter 20 PSI.

6. Determine how the transmitter will obtain pressure data, and perform the required setup.

Option	Setup
A user-configured static pressure value	<ol style="list-style-type: none"> a. Set Pressure Units to the desired unit. b. Set External Pressure to the desired value.
Polling for pressure	<ol style="list-style-type: none"> a. Ensure that the primary mA output has been wired to support HART polling. b. Choose ProLink > Configuration > Polled Variables. c. Choose an unused polling slot. d. Set Polling Control to Poll As Primary or Poll as Secondary, and click Apply. e. Set External Tag to the HART tag of the external pressure device. f. Set Variable Type to Pressure. <hr/> <p>Tip</p> <ul style="list-style-type: none"> • Poll as Primary: No other HART masters will be on the network. • Poll as Secondary: Other HART masters will be on the network. The Field Communicator is not a HART master. <hr/>

Option	Setup
A value written by digital communications	a. Set Pressure Units to the desired unit. b. Perform the necessary host programming and communications setup to write pressure data to the transmitter at appropriate intervals. <hr/> Note If the Weights & Measures application is implemented and the transmitter is secured, digital communications cannot be used to write temperature data to the transmitter.

Postrequisites

If you are using an external pressure value, verify the setup by choosing ProLink > Process Variables and checking the value displayed in External Pressure.

4.9.2 Configure pressure compensation using ProLink III

Prerequisites

You will need the flow factor, density factor, and calibration pressure values for your sensor.

- For the flow factor and density factor, see the product data sheet for your sensor.
- For the calibration pressure, see the calibration sheet for your sensor. If the data is unavailable, use 20 PSI.

Procedure

1. Choose Device Tools > Configuration > Process Measurement > Pressure Compensation.
2. Set Pressure Compensation Status to Enabled.
3. Enter Flow Calibration Pressure for your sensor.

The calibration pressure is the pressure at which your sensor was calibrated, and defines the pressure at which there is no pressure effect. If the data is unavailable, enter 20 PSI.

4. Enter Flow Factor for your sensor.

The flow factor is the percent change in the flow rate per PSI. When entering the value, reverse the sign.

Example:

If the flow factor is 0.000004 % per PSI, enter -0.000004 % per PSI.

5. Enter Density Factor for your sensor.

The density factor is the change in fluid density, in g/cm³/PSI. When entering the value, reverse the sign.

Example:

If the density factor is 0.000006 g/cm³/PSI, enter -0.000006 g/cm³/PSI.

6. Set Pressure Source to the method that the transmitter will use to obtain pressure data.

Option	Description
Poll for external value	The transmitter will poll an external pressure device, using HART protocol over the primary mA output.
Static or Digital Communications	<p>The transmitter will use the pressure value that it reads from memory.</p> <ul style="list-style-type: none"> • Static: The configured value is used. • Digital Communications: A host writes transmitter data to transmitter memory. <hr/> <p>Note</p> <p>If the Weights & Measures application is implemented and the transmitter is secured, digital communications cannot be used to write temperature data to the transmitter.</p>

7. If you chose to poll for pressure data:

- a. Select the Polling Slot to use.

The transmitter has two polling slots. You can use one for pressure and the other for temperature, if concentration measurement or petroleum measurement is enabled.

- b. Set Polling Control to Poll as Primary or Poll as Secondary, and click Apply.

Tip

- Poll as Primary: No other HART masters will be on the network.
 - Poll as Secondary: Other HART masters will be on the network. The Field Communicator is not a HART master.
-

- c. Set External Device Tag to the HART tag of the external pressure device, and click Apply.

8. If you chose to use a static pressure value:

- a. Set Pressure Unit to the desired unit.
- b. Set Static or Current Pressure to the value to use, and click Apply

9. If you want to use digital communications, click Apply, then perform the necessary host programming and communications setup to write temperature data to the transmitter at appropriate intervals.

Postrequisites

If you are using an external pressure value, verify the setup by checking the External Pressure value displayed in the Inputs area of the main window.

4.9.3 Configure pressure compensation using the Field Communicator

Prerequisites

You will need the flow factor, density factor, and calibration pressure values for your sensor.

- For the flow factor and density factor, see the product data sheet for your sensor.
- For the calibration pressure, see the calibration sheet for your sensor. If the data is unavailable, use 20 PSI.

Procedure

1. Choose Online > Configure > Manual Setup > Measurements > External Pressure/Temperature > Pressure.
2. Set Pressure Compensation to Enabled.
3. Enter Flow Cal Pressure for your sensor.

The calibration pressure is the pressure at which your sensor was calibrated, and defines the pressure at which there is no pressure effect. If the data is unavailable, enter 20 PSI.

4. Enter Flow Press Factor for your sensor.

The flow factor is the percent change in the flow rate per PSI. When entering the value, reverse the sign.

Example:

If the flow factor is 0.000004 % per PSI, enter -0.000004 % per PSI.

5. Enter Dens Press Factor for your sensor.

The density factor is the change in fluid density, in g/cm³/PSI. When entering the value, reverse the sign.

Example:

If the density factor is 0.000006 g/cm³/PSI, enter -0.000006 g/cm³/PSI.

6. Determine how the transmitter will obtain pressure data, and perform the required setup.

Option	Setup
A user-configured static pressure value	<ol style="list-style-type: none"> Set Pressure Unit to the desired unit. Set Compensation Pressure to the desired value.
Polling for pressure	<ol style="list-style-type: none"> Ensure that the primary mA output has been wired to support HART polling. Choose Online > Configure > Manual Setup > Measurements > External Pressure/Temperature > External Polling. Set Poll Control to Poll As Primary Host or Poll as Secondary Host. Choose an unused polling slot. Set External Tag to the HART tag of the external pressure device. Set Polled Variable to Pressure. <hr/> <p>Tip</p> <ul style="list-style-type: none"> Poll as Primary: No other HART masters will be on the network. Poll as Secondary: Other HART masters will be on the network. The Field Communicator is not a HART master.
A value written by digital communications	<ol style="list-style-type: none"> Set Pressure Unit to the desired unit. Perform the necessary host programming and communications setup to write pressure data to the transmitter at appropriate intervals. <hr/> <p>Note</p> <p>If the Weights & Measures application is implemented and the transmitter is secured, digital communications cannot be used to write temperature data to the transmitter.</p>

Postrequisites

If you are using an external pressure value, verify the setup by choosing Service Tools > Variables > External Variables and checking the value displayed for External Pressure.

4.9.4 Options for Pressure Measurement Unit

The transmitter provides a standard set of measurement units for Pressure Measurement Unit. Different communications tools may use different labels for the units. In most applications, Pressure Measurement Unit should be set to match the pressure measurement unit used by the remote device.

Table 4-16: Options for Pressure Measurement Unit

Unit description	Label			
	Display	ProLink II	ProLink III	Field Communicator
Feet water @ 68 °F	FTH2O	Ft Water @ 68°F	Ft Water @ 68°F	ftH2O
Inches water @ 4 °C	INW4C	In Water @ 4°C	In Water @ 4°C	inH2O @4DegC
Inches water @ 60 °F	INW60	In Water @ 60°F	In Water @ 60°F	inH2O @60DegF
Inches water @ 68 °F	INH2O	In Water @ 68°F	In Water @ 68°F	inH2O
Millimeters water @ 4 °C	mmW4C	mm Water @ 4°C	mm Water @ 4°C	mmH2O @4DegC
Millimeters water @ 68 °F	mmH2O	mm Water @ 68°F	mm Water @ 68°F	mmH2O
Millimeters mercury @ 0 °C	mmHG	mm Mercury @ 0°C	mm Mercury @ 0°C	mmHg
Inches mercury @ 0 °C	INHG	In Mercury @ 0°C	In Mercury @ 0°C	inHG
Pounds per square inch	PSI	PSI	PSI	psi
Bar	BAR	bar	bar	bar
Millibar	mBAR	millibar	millibar	mbar
Grams per square centimeter	G/SCM	g/cm2	g/cm2	g/Sqcm
Kilograms per square centimeter	KG/SCM	kg/cm2	kg/cm2	kg/Sqcm
Pascals	PA	pascals	pascals	Pa
Kilopascals	KPA	Kilopascals	Kilopascals	kPa
Megapascals	MPA	megapascals	Megapascals	MPa
Torr @ 0 °C	TORR	Torr @ 0°C	Torr @ 0°C	torr
Atmospheres	ATM	atms	atms	atms

5 Configure device options and preferences

Topics covered in this chapter:

- *Configure the transmitter display*
- *Enable or disable operator actions from the display*
- *Configure security for the display menus*
- *Configure response time parameters*
- *Configure alarm handling*
- *Configure informational parameters*

5.1 Configure the transmitter display

You can control the process variables shown on the display and a variety of display behaviors.

The transmitter display parameters include:

- Display Language
- Display Variables
- Display Precision
- Update Period
- Auto Scroll and Auto Scroll Rate
- Backlight
- Status LED Blinking

5.1.1 Configure the language used for the display

Display	OFF-LINE MAINT > OFF-LINE CONFIG > DISPLAY > LANG
ProLink II	ProLink > Configuration > Display > Display Language
ProLink III	Device Tools > Configuration > Transmitter Display > General
Field Communicator	Configure > Manual Setup > Display > Language

Overview

Display Language controls the language used for process data and menus on the display.

Procedure

Select the language you want to use.

The languages available depend on your transmitter model and version.

5.1.2 Configure the process variables shown on the display

Display	<i>Not available</i>
ProLink II	ProLink > Configuration > Display
ProLink III	Device Tools > Configuration > Transmitter Display > Display Variables
Field Communicator	Configure > Manual Setup > Display > Display Variables

Overview

You can control the process variables shown on the display and the order in which they appear. The display can scroll through up to 15 process variables in any order you choose. In addition, you can repeat variables or leave slots unassigned.

Restrictions

- You cannot set Display Variable 1 to None. Display Variable 1 must be set to a process variable.
- If you have configured Display Variable 1 to track the primary mA output, you cannot change the setting of Display Variable 1 using this procedure. To change the setting of Display Variable 1, you must change the configuration of mA Output Process Variable for the primary mA output.

Note

If you configure a display variable as a volume process variable and then change Volume Flow Type, the display variable is automatically changed to the equivalent process variable. For example, Volume Flow Rate would be changed to Gas Standard Volume Flow Rate.

Procedure

For each display variable you want to change, assign the process variable you want to use.

Example: Default display variable configuration

Display variable	Process variable assignment
Display Variable 1	Mass flow
Display Variable 2	Mass total
Display Variable 3	Volume flow
Display Variable 4	Volume total
Display Variable 5	Density
Display Variable 6	Temperature
Display Variable 7	External pressure
Display Variable 8	Mass flow
Display Variable 9	None

Display variable	Process variable assignment
Display Variable 10	None
Display Variable 11	None
Display Variable 12	None
Display Variable 13	None
Display Variable 14	None
Display Variable 15	None

Configure Display Variable 1 to track the primary mA output

Display	OFF-LINE MAINT > OFF-LINE CONFIG > DISPLY > VAR 1
ProLink II	ProLink > Configuration > Display > Display Options > Display Variable 1 Selection
ProLink III	Device Tools > Configuration > Transmitter Display > Display Security
Field Communicator	<i>Not available</i>

Overview

You can configure Display Variable 1 to track mA Output Process Variable for the primary mA output. When tracking is enabled, you can control Display Variable 1 from the display menu.

Tip

This feature is the only way to configure a display variable from the display menus, and it applies only to Display Variable 1.

Procedure

Configure Display Variable 1 to track the primary mA output.

Display Variable 1 will automatically be set to match mA Output Process Variable for the primary mA output. If you change the configuration of mA Output Process Variable, Display Variable 1 will be updated automatically.

5.1.3

Configure the precision of variables shown on the display

Display	<i>Not available</i>
ProLink II	ProLink > Configuration > Display > Display Precision
ProLink III	Device Tools > Configuration > Transmitter Display > Display Variables
Field Communicator	Configure > Manual Setup > Display > Decimal Places

Overview

Setting Display Precision determines the precision (number of decimal places) shown on the display. You can set Display Precision independently for each variable. Setting Display Precision does not affect the actual value of the process variable.

Procedure

1. Select a process variable.
2. Set Display Precision to the number of decimal places you want shown when the process variable appears on the display.

For temperature and density process variables, the default value is 2 decimal places. For all other process variables, the default value is 4 decimal places. The range is 0 to 5.

Tip

The lower the selected precision, the greater the process change must be for it to be reflected on the display. Do not set Display Precision value too low or too high to be useful.

5.1.4 Configure the refresh rate of data shown on the display

Display	OFF-LINE MAINT > OFF-LINE CONFIG > DISPLAY > RATE
ProLink II	ProLink > Configuration > Display > Update Period
ProLink III	Device Tools > Configuration > Transmitter Display > Display Variables
Field Communicator	Configure > Manual Setup > Display > Display Variable Menu Features > Refresh Rate

Overview

You can set Update Period to control how frequently data is refreshed on the display.

Procedure

Set Update Period to the desired value.

The default value is 200 milliseconds. The range is 100 milliseconds to 10,000 milliseconds (10 seconds).

5.1.5 Enable or disable automatic scrolling through the display variables

Display	OFF-LINE MAINT > OFF-LINE CONFIG > DISPLAY > AUTO SCROLL
ProLink II	ProLink > Configuration > Display > Display Options > Display Auto Scroll
ProLink III	Device Tools > Configuration > Transmitter Display > General
Field Communicator	Configure > Manual Setup > Display > Display Variable Menu Features > Auto Scroll

Overview

You can configure the display to automatically scroll through the configured display variables or to show a single display variable until the operator activates Scroll. When you set automatic scrolling, you can also configure the length of time each display variable is displayed.

Procedure

1. Enable or disable Auto Scroll as desired.

Option	Description
Enabled	The display automatically scrolls through each display variable as specified by Scroll Rate. The operator can move to the next display variable at any time using Scroll.
Disabled (default)	The display shows Display Variable 1 and does not scroll automatically. The operator can move to the next display variable at any time using Scroll.

2. If you enabled Auto Scroll, set Scroll Rate as desired.

The default value is 10 seconds.

Tip

Scroll Rate may not be available until you apply Auto Scroll.

5.1.6 Enable or disable the display backlight

Display	OFF-LINE MAINT > OFF-LINE CONFIG > DISPLAY > BKLT
ProLink II	ProLink > Configuration > Display > Display Options > Display Backlight On/Off
ProLink III	Device Tools > Configuration > Transmitter Display > General
Field Communicator	Configure > Manual Setup > Display > Backlight

Overview

You can enable or disable the display backlight.

Procedure

Enable or disable Backlight.

The default setting is Enabled.

5.1.7 Enable or disable Status LED Blinking

Display	<i>Not available</i>
ProLink II	ProLink > Configuration > Display > Display Options > Display Status LED Blinking
ProLink III	Device Tools > Configuration > Transmitter Display > General
Field Communicator	Configure > Manual Setup > Display > Display Variable Menu Features > Status LED Blinking

Overview

By default, the status LED blinks (flashes) to indicate unacknowledged alarms. If you disable Status LED Blinking, the status LED does not blink, whether alarms are acknowledged or not. It still changes color to indicate active alarms.

Procedure

Enable or disable Status LED Blinking.

The default setting is Enabled.

5.2 Enable or disable operator actions from the display

You can configure the transmitter to let the operator perform specific actions using the display.

You can configure the following:

- Totalizer Start/Stop
- Totalizer Reset
- Acknowledge All Alarms

5.2.1 Enable or disable Totalizer Start/Stop from the display

Display	OFF-LINE MAINT > OFF-LINE CONFIG > DISPLAY > TOTALS STOP
ProLink II	ProLink > Configuration > Display > Display Options > Display Start/Stop Totalizers
ProLink III	Device Tools > Configuration > Totalizer Control Methods
Field Communicator	Configure > Manual Setup > Display > Display Variable Menu Features > Start/Stop Totalizers

Overview

You can control whether or not the operator is able to start and stop totalizers and inventories from the display.

Restrictions

- You cannot start and stop totalizers individually from the display. All totalizers are started or stopped together.
- You cannot start or stop inventories separately from totalizers. When a totalizer is started or stopped, the associated inventory is also started or stopped.
- If the petroleum measurement application is installed on your computer, the operator must enter the off-line password to perform this function, even if the off-line password is not enabled.

Procedure

1. Ensure that at least one totalizer is configured as a display variable.
2. Enable or disable Totalizer Reset as desired.

Option	Description
Enabled	Operators can start and stop totalizers and inventories from the display, if at least one totalizer is configured as a display variable.
Disabled (default)	Operators cannot start and stop totalizers and inventories from the display.

5.2.2 Enable or disable Totalizer Reset from the display

Display	OFF-LINE MAINT > OFF-LINE CONFIG > DISPLAY > TOTALS RESET
ProLink II	ProLink > Configuration > Display > Display Options > Display Totalizer Reset
ProLink III	Device Tools > Configuration > Totalizer Control Methods
Field Communicator	Configure > Manual Setup > Display > Display Variable Menu Features > Totalizer Reset

Overview

You can configure whether or not the operator is able to reset totalizers from the display.

Restrictions

- This parameter does not apply to inventories. You cannot reset inventories from the display.
- You cannot use the display to reset all totalizers as a group. You must reset totalizers individually.
- If the petroleum measurement application is installed on your computer, the operator must enter the off-line password to perform this function, even if the off-line password is not enabled.

Procedure

1. Ensure that the totalizers you want to reset have been configured as display variables.

If the totalizer is not configured as a display variable, the operator will not be able to reset it.

2. Enable or disable resetting the totalizer as desired.

Option	Description
Enabled	Operators can reset a totalizer from the display, if the totalizer is configured as a display variable.
Disabled (default)	Operators cannot reset totalizers from the display.

5.2.3 Enable or disable the Acknowledge All Alarms display command

Display	OFF-LINE MAINT > OFF-LINE CONFIG > DISPLAY > ALARM
ProLink II	ProLink > Configuration > Display > Display Options > Display Ack All Alarms
ProLink III	Device Tools > Configuration > Transmitter Display > Ack All
Field Communicator	Configure > Manual Setup > Display > Offline Variable Menu Features > Acknowledge All

Overview

You can configure whether or not the operator can use a single command to acknowledge all alarms from the display.

Procedure

1. Ensure that the alarm menu is accessible from the display.

To acknowledge alarms from the display, operators must have access to the alarm menu.

2. Enable or disable Acknowledge All Alarms as desired.

Option	Description
Enabled (default)	Operators can use a single display command to acknowledge all alarms at once.
Disabled	Operators cannot acknowledge all alarms at once, they must be acknowledged individually.

5.3 Configure security for the display menus

Display	OFF-LINE MAINT > OFF-LINE CONFIG > DISPLAY
ProLink II	ProLink > Configuration > Display > Display Options
ProLink III	Device Tools > Configuration > Transmitter Display > Display Security
Field Communicator	Configure > Manual Setup > Display > Offline Variable Menu Features

Overview

You can control operator access to different sections of the display off-line menu. You can also configure a password to control access.

Procedure

1. To control operator access to the maintenance section of the off-line menu, enable or disable Off-Line Menu.

Option	Description
Enabled (default)	Operator can access the maintenance section of the off-line menu. This access is required for configuration and calibration, but is not required to view alarms or to access Smart Meter Verification (if applicable).
Disabled	Operator cannot access the maintenance section of the off-line menu.

2. To control operator access to the alarm menu, enable or disable Alarm Menu.

Option	Description
Enabled (default)	Operator can access the alarm menu. This access is required to view and acknowledge alarms, but is not required for Smart Meter Verification (if applicable), configuration, or calibration.
Disabled	Operator cannot access the alarm menu.

Note

The transmitter status LED changes color to indicate that there are active alarms, but does not show specific alarms.

3. To require a password for access to the maintenance section of the off-line menu and the Smart Meter Verification menu, enable or disable Off-Line Password.

Option	Description
Enabled	Operator is prompted for the off-line password at entry to the Smart Meter Verification menu (if applicable) or entry to the maintenance section of the off-line menu.
Disabled (default)	No password is required for entry to the Smart Meter Verification menu (if applicable) or entry to the maintenance section of the off-line menu.

4. To require a password to access the alarm menu, enable or disable Alarm Password.

Option	Description
Enabled	Operator is prompted for the off-line password at entry to the alarm menu.
Disabled (default)	No password is required for entry to the alarm menu.

If both Off-Line Password and Alarm Password are enabled, the operator is prompted for the off-line password to access the off-line menu, but is not prompted thereafter.

5. (Optional) Set Off-Line Password to the desired value.

The same value is used for both the off-line password and the alarm password. The default value is 1234. The range is 0000 to 9999.

Tip

Record your password for future reference.

5.4 Configure response time parameters

You can configure the rate at which process data is polled and process variables are calculated.

Response time parameters include:

- Update Rate
- Calculation Speed (Response Time)

5.4.1 Configure Update Rate

Display	<i>Not available</i>
ProLink II	ProLink > Configuration > Device > Update Rate
ProLink III	Device Tools > Configuration > Process Measurement > Response > Update Rate
Field Communicator	Configure > Manual Setup > Measurements > Update Rate

Overview

Update Rate controls the rate at which process data is polled and process variables are calculated. Update Rate = Special produces faster and “noisier” response to changes in the process. Do not use Special mode unless required by your application.

Tip

For systems with a standard core processor, Special mode can improve performance for applications with entrained air or Empty-Full-Empty conditions. This does not apply to systems with an enhanced core processor.

Prerequisites

Before setting Update Rate to Special:

- Check the effects of Special mode on specific process variables.
- Contact Micro Motion.

Procedure

1. Set Update Rate as desired.

Option	Description
Normal	All process data is polled at the rate of 20 times per second (20 Hz). All process variables are calculated at 20 Hz. This option is appropriate for most applications.
Special	A single, user-specified process variable is polled at the rate of 100 times per second (100 Hz). Other process data is polled at 6.25 Hz). Some process, diagnostic, and calibration data is not polled. All available process variables are calculated at 100 Hz. Use this option only if required by your application.

If you change Update Rate, the settings for Flow Damping, Density Damping, and Temperature Damping are automatically adjusted.

2. If you set Update Rate to Special, select the process variable to be polled at 100 Hz.

Effects of Update Rate = Special

Incompatible features and functions

Special mode is not compatible with the following features and functions:

- Enhanced events. Use basic events instead.
- All calibration procedures.
- Zero verification.
- Restoring the factory zero or the prior zero.

If required, you can switch to Normal mode, perform the desired procedures, and then return to Special mode.

Process variable updates

Some process variables are not updated when Special mode is enabled.

Table 5-1: Special mode and process variable updates

Always polled and updated	Updated only when the petroleum measurement application is disabled	Never updated
<ul style="list-style-type: none"> • Mass flow • Volume flow • Gas standard volume flow • Density • Temperature • Drive gain • LPO amplitude • Status [contains Event 1 and Event 2 (basic events)] • Raw tube frequency • Mass total • Volume total • Gas standard volume total • Temperature-corrected volume total • Temperature-corrected density • Temperature-corrected volume flow • Batch-weighted average temperature • Batch-weighted average density 	<ul style="list-style-type: none"> • RPO amplitude • Board temperature • Core input voltage • Mass inventory • Volume inventory • Gas standard volume inventory 	<p>All other process variables and calibration data. They retain the values held at the time you enabled Special mode.</p>

5.4.2 Configure Calculation Speed (Response Time)

Display	<i>Not available</i>
ProLink II	ProLink > Configuration > Device > Response Time
ProLink III	Device Tools > Configuration > Process Measurement > Response > Calculation Speed
Field Communicator	<i>Not available</i>

Overview

Calculation Speed is used to apply a different algorithm to the calculation of process variables from the raw process data. Calculation Speed = Special produces faster and “noisier” response to changes in the process.

In ProLink II, Calculation Speed is called Response Time.

Restriction

Calculation Speed is available only on systems with the enhanced core processor.

Tip

You can use Calculation Speed = Special with either setting of Update Rate. The parameters control different aspects of flowmeter processing.

Procedure

Set Calculation Speed as desired.

Option	Description
Normal	Transmitter calculates process variables at the standard speed.
Special	Transmitter calculates process variables at a faster speed.

5.5 Configure alarm handling

The alarm handling parameters control the transmitter’s response to process and device conditions.

Alarm handling parameters include:

- Fault Timeout
- Status Alarm Severity

5.5.1 Configure Fault Timeout

Display	<i>Not available</i>
ProLink II	ProLink > Configuration > Analog Output > Last Measured Value Timeout ProLink > Configuration > Frequency/Discrete Output > Frequency > Last Measured Value Timeout
ProLink III	Device Tools > Configuration > Fault Processing
Field Communicator	Configure > Alert Setup > Alert Severity > Fault Timeout

Overview

Fault Timeout controls the delay before fault actions are performed.

Restriction

Fault Timeout is applied only to the following alarms (listed by Status Alarm Code): A003, A004, A005, A008, A016, A017, A033. For all other alarms, fault actions are performed as soon as the alarm is detected.

Procedure

Set Fault Timeout as desired.

The default value is 0 seconds. The range is 0 to 60 seconds.

If you set Fault Timeout to 0, fault actions are performed as soon as the alarm condition is detected.

The fault timeout period begins when the transmitter detects an alarm condition. During the fault timeout period, the transmitter continues to report its last valid measurements.

If the fault timeout period expires while the alarm is still active, the fault actions are performed. If the alarm condition clears before the fault timeout expires, no fault actions are performed.

Tip

ProLink II allows you to set Fault Timeout in two locations. However, there is only one parameter, and the same setting is applied to all outputs.

5.5.2 Configure Status Alarm Severity

Display	<i>Not available</i>
ProLink II	ProLink > Configuration > Alarm > Severity
ProLink III	Device Tools > Configuration > Alert Severity
Field Communicator	Configure > Alert Setup > Alert Severity > Set Alert Severity

Overview

Use Status Alarm Severity to control the fault actions that the transmitter performs when it detects an alarm condition.

Restrictions

- For some alarms, Status Alarm Severity is not configurable.
- For some alarms, Status Alarm Severity can be set only to two of the three options.

Tip

Micro Motion recommends using the default settings for Status Alarm Severity unless you have a specific requirement to change them.

Procedure

1. Select a status alarm.
2. For the selected status alarm, set Status Alarm Severity as desired.

Option	Description
Fault	<p>Actions when fault is detected:</p> <ul style="list-style-type: none"> • The alarm is posted to the Alert List. • Outputs go to the configured fault action (after Fault Timeout has expired, if applicable). • Digital communications go to the configured fault action (after Fault Timeout has expired, if applicable). • The status LED (if available) changes to red or yellow (depending on alarm severity). <p>Actions when alarm clears:</p> <ul style="list-style-type: none"> • Outputs return to normal behavior. • Digital communications return to normal behavior. • The status LED (if available) returns to green and may or may not flash.
Informational	<p>Actions when fault is detected:</p> <ul style="list-style-type: none"> • The alarm is posted to the Alert List. • The status LED (if available) changes to red or yellow (depending on alarm severity). <p>Actions when alarm clears:</p> <ul style="list-style-type: none"> • The status LED (if available) returns to green and may or may not flash.
Ignore	No action

Status alarms and options for Status Alarm Severity

Table 5-2: Status alarms and Status Alarm Severity

Alarm code	Status message	Default severity	Notes	Configurable?
A001	EEPROM Error (Core Processor)	Fault		No
A002	RAM Error (Core Processor)	Fault		No
A003	No Sensor Response	Fault		Yes
A004	Temperature Overrange	Fault		No
A005	Mass Flow Rate Overrange	Fault		Yes
A006	Characterization Required	Fault		Yes
A008	Density Overrange	Fault		Yes
A009	Transmitter Initializing/ Warming Up	Fault		Yes
A010	Calibration Failure	Fault		No
A011	Zero Calibration Failed: Low	Fault		Yes
A012	Zero Calibration Failed: High	Fault		Yes
A013	Zero Calibration Failed: Unstable	Fault		Yes
A014	Transmitter Failure	Fault		No
A016	Sensor RTD Failure	Fault		Yes
A017	T-Series RTD Failure	Fault		Yes
A018	EEPROM Error (Transmitter)	Fault		No
A019	RAM Error (Transmitter)	Fault		No
A020	No Flow Cal Value	Fault		Yes
A021	Incorrect Sensor Type (K1)	Fault		No
A022	Configuration Database Corrupt (Core Processor)	Fault	Applies only to flowmeters with the standard core processor.	No
A023	Internal Totals Corrupt (Core Processor)	Fault	Applies only to flowmeters with the standard core processor.	No
A024	Program Corrupt (Core Processor)	Fault	Applies only to flowmeters with the standard core processor.	No
A025	Boot Sector Fault (Core Processor)	Fault	Applies only to flowmeters with the standard core processor.	No
A026	Sensor/Transmitter Com- munications Failure	Fault		No
A027	Security Breach	Fault		No
A028	Core Processor Write Fail- ure	Fault		No

Table 5-2: Status alarms and Status Alarm Severity (continued)

Alarm code	Status message	Default severity	Notes	Configurable?
A031	Low Power	Fault	Applies only to flowmeters with the enhanced core processor.	No
A032	Meter Verification in Progress: Outputs to Fault	Varies	Applies only to transmitters with Smart Meter Verification. If outputs are set to Last Measured Value, severity is Info. If outputs are set to Fault, severity is Fault.	No
A033	Insufficient Right/Left Pick-off Signal	Fault	Applies only to flowmeters with the enhanced core processor.	Yes
A034	Meter Verification Failed	Informational	Applies only to transmitters with Smart Meter Verification.	Yes
A035	Meter Verification Aborted	Informational	Applies only to transmitters with Smart Meter Verification.	Yes
A100	mA Output 1 Saturated	Informational	Can be set to either Informational or Ignore, but cannot be set to Fault.	Yes
A101	mA Output 1 Fixed	Informational	Can be set to either Informational or Ignore, but cannot be set to Fault.	Yes
A102	Drive Overrange	Informational		Yes
A103	Data Loss Possible (Totals and Inventories)	Informational	Applies only to flowmeters with the standard core processor. Can be set to either Informational or Ignore, but cannot be set to Fault.	Yes
A104	Calibration in Progress	Informational	Can be set to either Informational or Ignore, but cannot be set to Fault.	Yes
A105	Slug Flow	Informational		Yes
A106	Burst Mode Enabled	Informational	Can be set to either Informational or Ignore, but cannot be set to Fault.	Yes
A107	Power Reset Occurred	Informational	Normal transmitter behavior; occurs after every power cycle.	Yes
A108	Basic Event 1 On	Informational	Applies only to basic events.	Yes
A109	Basic Event 2 On	Informational	Applies only to basic events.	Yes
A110	Frequency Output Saturated	Informational	Can be set to either Informational or Ignore, but cannot be set to Fault.	Yes
A111	Frequency Output Fixed	Informational	Can be set to either Informational or Ignore, but cannot be set to Fault.	Yes
A112	Upgrade Transmitter Software	Informational	Applies only to systems with transmitter software earlier than v5.0.	Yes
A113	mA Output 2 Saturated	Informational	Can be set to either Informational or Ignore, but cannot be set to Fault.	Yes

Table 5-2: Status alarms and Status Alarm Severity (continued)

Alarm code	Status message	Default severity	Notes	Configurable?
A114	mA Output 2 Fixed	Informational	Can be set to either Informational or Ignore, but cannot be set to Fault.	Yes
A115	No External Input or Polled Data	Informational		Yes
A116	Temperature Overrange (Petroleum)	Informational	Applies only to transmitters with the petroleum measurement application.	Yes
A117	Density Overrange (Petroleum)	Informational	Applies only to transmitters with the petroleum measurement application.	Yes
A118	Discrete Output 1 Fixed	Informational	Can be set to either Informational or Ignore, but cannot be set to Fault.	Yes
A119	Discrete Output 2 Fixed	Informational	Can be set to either Informational or Ignore, but cannot be set to Fault.	Yes
A120	Curve Fit Failure (Concentration)	Informational	Applies only to transmitters with the concentration measurement application.	No
A121	Extrapolation Alarm (Concentration)	Informational	Applies only to transmitters with the concentration measurement application.	Yes
A131	Meter Verification in Progress: Outputs to Last Measured Value	Informational	Applies only to transmitters with Smart Meter Verification.	Yes
A132	Sensor Simulation Active	Informational	Applies only to flowmeters with the enhanced core processor. Can be set to either Informational or Ignore, but cannot be set to Fault.	Yes
A141	DDC trigger(s) have completed	Informational	Applies only to flowmeters with the enhanced core processor. Can be set to either Informational or Ignore, but cannot be set to Fault.	Yes

5.6 Configure informational parameters

The informational parameters can be used to identify or describe your flowmeter but they are not used in transmitter processing and are not required.

The informational parameters include:

- Device parameters
 - Descriptor

- Message
- Date
- Sensor parameters
 - Sensor Serial Number
 - Sensor Material
 - Sensor Liner Material
 - Sensor Flange Type

5.6.1 Configure Descriptor

Display	<i>Not available</i>
ProLink II	ProLink > Configuration > Device > Descriptor
ProLink III	Device Tools > Configuration > Informational Parameters > Transmitter
Field Communicator	Configure > Manual Setup > Info Parameters > Transmitter Info > Descriptor

Overview

Descriptor lets you store a description in transmitter memory. The description is not used in processing and is not required.

Procedure

Enter a description for the transmitter.

You can use up to 16 characters for the description.

5.6.2 Configure Message

Display	<i>Not available</i>
ProLink II	ProLink > Configuration > Device > Message
ProLink III	Device Tools > Configuration > Informational Parameters > Transmitter
Field Communicator	Configure > Manual Setup > Info Parameters > Transmitter Info > Message

Overview

Message lets you store a short message in transmitter memory. This parameter is not used in processing and is not required.

Procedure

Enter a short message for the transmitter.

Your message can be up to 32 characters long.

5.6.3 Configure Date

Display	<i>Not available</i>
ProLink II	ProLink > Configuration > Device > Date
ProLink III	Device Tools > Configuration > Informational Parameters > Transmitter
Field Communicator	Configure > Manual Setup > Info Parameters > Transmitter Info > Date

Overview

Date lets you store a static date (not updated by the transmitter) in transmitter memory. This parameter is not used in processing and is not required.

Procedure

Enter the date you want to use, in the form mm/dd/yyyy.

Tip

ProLink II and ProLink III provide a calendar tool to help you select the date.

5.6.4 Configure Sensor Serial Number

Display	<i>Not available</i>
ProLink II	ProLink > Configuration > Sensor > Sensor S/N
ProLink III	Device Tools > Configuration > Informational Parameters > Sensor
Field Communicator	Configure > Manual Setup > Info Parameters > Sensor Information > Sensor Serial Number

Overview

Sensor Serial Number lets you store the serial number of the sensor component of your flowmeter in transmitter memory. This parameter is not used in processing and is not required.

Procedure

1. Obtain the sensor serial number from your sensor tag.
2. Enter the serial number in the Sensor Serial Number field.

5.6.5 Configure Sensor Material

Display	<i>Not available</i>
ProLink II	ProLink > Configuration > Sensor > Sensor Matl
ProLink III	Device Tools > Configuration > Informational Parameters > Sensor
Field Communicator	Configure > Manual Setup > Info Parameters > Sensor Information > Tube Wetted Material

Overview

Sensor Material lets you store the type of material used for your sensor's wetted parts in transmitter memory. This parameter is not used in processing and is not required.

Procedure

1. Obtain the material used for your sensor's wetted parts from the documents shipped with your sensor, or from a code in the sensor model number.
To interpret the model number, refer to the product data sheet for your sensor.
2. Set Sensor Material to the appropriate option.

5.6.6 Configure Sensor Liner Material

Display	<i>Not available</i>
ProLink II	ProLink > Configuration > Sensor > Liner Matl
ProLink III	Device Tools > Configuration > Informational Parameters > Sensor
Field Communicator	Configure > Manual Setup > Info Parameters > Sensor Information > Tube Lining

Overview

Sensor Liner Material lets you store the type of material used for your sensor liner in transmitter memory. This parameter is not used in processing and is not required.

Procedure

1. Obtain your sensor's liner material from the documents shipped with your sensor, or from a code in the sensor model number.
To interpret the model number, refer to the product data sheet for your sensor.
2. Set Sensor Liner Material to the appropriate option.

5.6.7 Configure Sensor Flange Type

Display	<i>Not available</i>
ProLink II	ProLink > Configuration > Sensor > Flange
ProLink III	Device Tools > Configuration > Informational Parameters > Sensor
Field Communicator	Configure > Manual Setup > Info Parameters > Sensor Information > Sensor Flange

Overview

Sensor Flange Type lets you store your sensor's flange type in transmitter memory. This parameter is not used in processing and is not required.

Procedure

1. Obtain your sensor's flange type from the documents shipped with your sensor, or from a code in the sensor model number.
To interpret the model number, refer to the product data sheet for your sensor.
2. Set Sensor Flange Type to the appropriate option.

6 Integrate the meter with the control system

Topics covered in this chapter:

- [Configure the transmitter channels](#)
- [Configure the mA output](#)
- [Configure the frequency output](#)
- [Configure the discrete output](#)
- [Configure events](#)
- [Configure digital communications](#)

6.1 Configure the transmitter channels

Display	OFF-LINE MAINT > OFF-LINE CONFIG > IO > CH B
ProLink II	ProLink > Configuration > Frequency/Discrete Output
ProLink III	Device Tools > Configuration > I/O > Channels
Field Communicator	Configure > Manual Setup > Inputs/Outputs > Channels > Channel B

Overview

You can configure Channel B on your transmitter to operate as a frequency output or a discrete output. The channel configuration must match the wiring at the transmitter terminals.

Prerequisites

To avoid causing process errors:

- Configure the channels before configuring the outputs.
- Before changing the channel configuration, ensure that all control loops affected by the channel are under manual control.

Procedure

Set Channel B as desired.

Option	Description
Frequency output	Channel B will operate as a frequency output.
Discrete output	Channel B will operate as a discrete output.

Postrequisites

For each channel that you configured, perform or verify the corresponding input or output configuration. When the configuration of a channel is changed, the channel's behavior will be controlled by the configuration that is stored for the selected input or output type, and the stored configuration may not be appropriate for your process.

After verifying channel and output configuration, return the control loop to automatic control.

6.2 Configure the mA output

The mA output is used to report the configured process variable. The mA output parameters control how the process variable is reported. Your transmitter has one mA output: Channel A.

The mA output parameters include:

- mA Output Process Variable
- Lower Range Value (LRV) and Upper Range Value (URV)
- AO Cutoff
- Added Damping
- AO Fault Action and AO Fault Value

Important

Whenever you change an mA output parameter, verify all other mA output parameters before returning the flowmeter to service. In some situations, the transmitter automatically loads a set of stored values, and these values may not be appropriate for your application.

6.2.1 Configure mA Output Process Variable

Display	OFF-LINE MAINT > OFF-LINE CONFIG > IO > CH A
ProLink II	ProLink > Configuration > Analog Output
ProLink III	Device Tools > Configuration > I/O > Outputs > mA Output
Field Communicator	Configure > Manual Setup > Inputs/Outputs > mA Output

Overview

Use mA Output Process Variable to select the variable that is reported over the mA output.

Prerequisites

- If you plan to configure the output to report volume flow, ensure that you have set Volume Flow Type as desired: Liquid or Gas Standard Volume.

- If you plan to configure an output to report a concentration measurement process variable, ensure that the concentration measurement application is configured so that the desired variable is available.
- If you are using the HART variables, be aware that changing the configuration of mA Output Process Variable will change the configuration of the HART Primary Variable (PV).
- If you have configured Display Variable 1 to track mA Output Process Variable, be aware that changing the configuration of mA Output Process Variable will change the contents of Display Variable 1.

Procedure

Set mA Output Process Variable as desired.

The default setting is Mass Flow Rate.

Options for mA Output Process Variable

The transmitter provides a basic set of options for mA Output Process Variable, plus several application-specific options. Different communications tools may use different labels for the options.

Table 6-1: Options for mA Output Process Variable

Process variable	Label			
	Display	ProLink II	ProLink III	Field Communicator
Standard				
Mass flow rate	MFLOW	Mass Flow Rate	Mass Flow Rate	Mass flo
Volume flow rate	VFLOW	Volume Flow Rate	Volume Flow Rate	Vol flo
Gas standard volume flow rate	GSV F	Gas Std Vol Flow Rate	Gas Standard Volume Flow Rate	Gas vol flo
Temperature	TEMP	Temperature	Temperature	Temp
Density	DENS	Density	Density	Dens
External pressure	EXT P	External Pressure	External Pressure	External pres
External temperature	EXT T	External Temperature	External Temperature	External temp
Drive gain	DGAIN	Drive Gain	Drive Gain	Driv signl
Petroleum measurement				
Temperature-corrected density	TCDEN	API: Temp Corrected Density	Density at Reference Temperature	TC Dens
Temperature-corrected (standard) volume flow rate	TCVOL	API: Temp Corrected Volume Flow	Volume Flow Rate at Reference Temperature	TC Vol
Average corrected density	AVE D	API: Avg Density	Average Density	TC Avg Dens
Average temperature	AVE T	API: Avg Temperature	Average Temperature	TC Avg Temp

Table 6-1: Options for mA Output Process Variable (continued)

Process variable	Label			
	Display	ProLink II	ProLink III	Field Communicator
Concentration measurement				
Density at reference	RDENS	CM: Density @ Reference	Density at Reference Temperature	ED Dens at Ref
Specific gravity	SGU	CM: Density (Fixed SG units)	Density (Fixed SG Units)	ED Dens (SGU)
Standard volume flow rate	STD V	CM: Std Vol Flow Rate	Volume Flow Rate at Reference Temperature	ED Std Vol flo
Net mass flow rate	NET M	CM: Net Mass Flow Rate	Net Mass Flow Rate	ED Net Mass flo
Net volume flow rate	NET V	CM: Net Vol Flow Rate	Net Volume Flow Rate	ED Net Vol flo
Concentration	CONC	CM: Concentration	Concentration	ED Concentration
Baume	BAUME	CM: Density (Fixed Baume Units)	Baume	ED Dens (Baume)

6.2.2 Configure Lower Range Value (LRV) and Upper Range Value (URV)

Display	<ul style="list-style-type: none"> OFF-LINE MAINT > OFF-LINE CONFG > IO > CH A > AO 4 mA OFF-LINE MAINT > OFF-LINE CONFG > IO > CH A > AO 20 mA
ProLink II	<ul style="list-style-type: none"> ProLink > Configuration > Analog Output > Primary Output > Lower Range Value ProLink > Configuration > Analog Output > Primary Output > Upper Range Value
ProLink III	Device Tools > Configuration > I/O > Outputs > mA Output
Field Communicator	<ul style="list-style-type: none"> Configure > Manual Setup > Inputs/Outputs > mA Output > mA Output Settings > PV LRV Configure > Manual Setup > Inputs/Outputs > mA Output > mA Output Settings > PV URV

Overview

The Lower Range Value (LRV) and Upper Range Value (URV) are used to scale the mA output, that is, to define the relationship between mA Output Process Variable and the mA output level.

Note

For transmitter software v5.0 and later, if you change LRV and URV from the factory default values, and you later change mA Output Process Variable, LRV and URV will not reset to the default values. For example, if you set mA Output Process Variable to Mass Flow Rate and change the LRV and URV, then you set mA Output Process Variable to Density, and finally you change mA Output Process Variable back to Mass Flow Rate, LRV and URV for Mass Flow Rate reset to the values that you configured. In earlier versions of the transmitter software, LRV and URV reset to the factory default values.

Procedure

Set LRV and URV as desired.

- LRV is the value of mA Output Process Variable represented by an output of 4 mA. The default value for LRV depends on the setting of mA Output Process Variable. Enter LRV in the measurement units that are configured for mA Output Process Variable.
- URV is the value of mA Output Process Variable represented by an output of 20 mA. The default value for URV depends on the setting of mA Output Process Variable. Enter URV in the measurement units that are configured for mA Output Process Variable.

Tips

For best performance:

- Set $LRV \geq LSL$ (lower sensor limit).
- Set $URV \leq USL$ (upper sensor limit).
- Set these values so that the difference between URV and LRV is \geq Min Span (minimum span).

Defining URV and LRV within the recommended values for Min Span, LSL, and USL ensures that the resolution of the mA output signal is within range of the bit precision of the D/A converter.

Note

You can set URV below LRV. For example, you can set URV to 50 and LRV to 100.

The mA output uses a range of 4–20 mA to represent mA Output Process Variable. Between LRV and URV, the mA output is linear with the process variable. If the process variable drops below LRV or rises above URV, the transmitter posts an output saturation alarm.

Default values for Lower Range Value (LRV) and Upper Range Value (URV)

Each option for mA Output Process Variable has its own LRV and URV. If you change the configuration of mA Output Process Variable, the corresponding LRV and URV are loaded and used.

Table 6-2: Default values for Lower Range Value (LRV) and Upper Range Value (URV)

Process variable	LRV	URV
All mass flow variables	-200.000 g/sec	200.000 g/sec
All liquid volume flow variables	-0.200 l/sec	0.200 l/sec
All density variables	0.000 g/cm ³	10.000 g/cm ³
All temperature variables	-240.000 °C	450.000 °C
Drive gain	0.00%	100.00%
Gas standard volume flow	-423.78 SCFM	423.78 SCFM
External temperature	-240.000 °C	450.000 °C
External pressure	0.000 bar	100.000 bar

Table 6-2: Default values for Lower Range Value (LRV) and Upper Range Value (URV)
(continued)

Process variable	LRV	URV
Concentration	0%	100%
Baume	0	10
Specific gravity	0	10

6.2.3 Configure AO Cutoff

Display	<i>Not available</i>
ProLink II	ProLink > Configuration > Analog Output > Primary Output > AO Cutoff
ProLink III	Device Tools > Configuration > I/O > Outputs > mA Output
Field Communicator	Configure > Manual Setup > Inputs/Outputs > mA Output > mA Output Settings > MAO Cutoff

Overview

AO Cutoff (Analog Output Cutoff) specifies the lowest mass flow rate, volume flow rate, or gas standard volume flow rate that will be reported through the mA output. Any flow rates below AO Cutoff will be reported as 0.

Restriction

AO Cutoff is applied only if mA Output Process Variable is set to Mass Flow Rate, Volume Flow Rate, or Gas Standard Volume Flow Rate. If mA Output Process Variable is set to a different process variable, AO Cutoff is not configurable, and the transmitter does not implement the AO cutoff function.

Procedure

Set AO Cutoff as desired.

The default value for AO Cutoff is 0.0 g/sec.

Tip

For most applications, the default value of AO Cutoff should be used. Contact Micro Motion customer service before changing AO Cutoff.

Interaction between AO Cutoff and process variable cutoffs

When mA Output Process Variable is set to a flow variable (for example, mass flow rate or volume flow rate), AO Cutoff interacts with Mass Flow Cutoff or Volume Flow Cutoff. The transmitter puts the cutoff into effect at the highest flow rate at which a cutoff is applicable.

Example: Cutoff interaction

Configuration:

- mA Output Process Variable = Mass Flow Rate
- Frequency Output Process Variable = Mass Flow Rate
- AO Cutoff = 10 g/sec
- Mass Flow Cutoff = 15 g/sec

Result: If the mass flow rate drops below 15 g/sec, all outputs representing mass flow will report zero flow.

Example: Cutoff interaction

Configuration:

- mA Output Process Variable = Mass Flow Rate
- Frequency Output Process Variable = Mass Flow Rate
- AO Cutoff = 15 g/sec
- Mass Flow Cutoff = 10 g/sec

Result:

- If the mass flow rate drops below 15 g/sec but not below 10 g/sec:
 - The mA output will report zero flow.
 - The frequency output will report the actual flow rate.
- If the mass flow rate drops below 10 g/sec, both outputs will report zero flow.

6.2.4 Configure Added Damping

Display	<i>Not available</i>
ProLink II	ProLink > Configuration > Analog Output > Primary Output > AO Added Damp
ProLink III	Device Tools > Configuration > I/O > Outputs > mA Output
Field Communicator	Configure > Manual Setup > Inputs/Outputs > mA Output > mA Output Settings > PV Added Damping

Overview

Damping is used to smooth out small, rapid fluctuations in process measurement. Damping Value specifies the time period (in seconds) over which the transmitter will spread changes in the reported process variable. At the end of the interval, the reported process variable will reflect 63% of the change in the actual measured value. Added Damping controls the amount of damping that will be applied to the mA output. It affects the reporting of mA Output Process Variable through the mA output only. It does not affect the reporting of that process variable via any other method (e.g., the frequency output or digital communications), or the value of the process variable used in calculations.

Note

Added Damping is not applied if the mA output is fixed (for example, during loop testing) or if the mA output is reporting a fault. Added Damping is applied while sensor simulation is active.

Procedure

Set Added Damping to the desired value.

The default value is 0.0 seconds.

When you specify a value for Added Damping, the transmitter automatically rounds the value down to the nearest valid value.

Note

Added Damping values are affected by the setting of Update Rate and 100 Hz Variable.

Table 6-3: Valid values for Added Damping

Setting of Update Rate	Process variable	Update rate in effect	Valid values for Added Damping
Normal	N/A	20 Hz	0.0, 0.1, 0.3, 0.75, 1.6, 3.3, 6.5, 13.5, 27.5, 55, 110, 220, 440
Special	100 Hz variable (if assigned to the mA output)	100 Hz	0.0, 0.04, 0.12, 0.30, 0.64, 1.32, 2.6, 5.4, 11, 22, 44, 88, 176, 350
	100 Hz variable (if not assigned to the mA output)	6.25 Hz	0.0, 0.32, 0.96, 2.40, 5.12, 10.56, 20.8, 43.2, 88, 176, 352
	All other process variables		

Interaction between Added Damping and process variable damping

When mA Output Process Variable is set to a flow variable, density, or temperature, Added Damping interacts with Flow Damping, Density Damping, or Temperature Damping. If multiple damping parameters are applicable, the effect of damping the process variable is calculated first, and the added damping calculation is applied to the result of that calculation.

Example: Damping interaction

Configuration:

- Flow Damping = 1 second
- mA Output Process Variable = Mass Flow Rate
- Added Damping = 2 seconds

Result: A change in the mass flow rate will be reflected in the mA output over a time period that is greater than 3 seconds. The exact time period is calculated by the transmitter according to internal algorithms which are not configurable.

6.2.5 Configure mA Output Fault Action and mA Output Fault Level

Display	<i>Not available</i>
ProLink II	<ul style="list-style-type: none"> ProLink > Configuration > Analog Output > Primary Output > AO Fault Action ProLink > Configuration > Analog Output > Primary Output > AO Fault Level
ProLink III	Device Tools > Configuration > Fault Processing
Field Communicator	Configure > Manual Setup > Inputs/Outputs > mA Output > MAO Fault Settings

Overview

mA Output Fault Action controls the behavior of the mA output if the transmitter encounters an internal fault condition.

Note

For some faults only: If Last Measured Value Timeout is set to a non-zero value, the transmitter will not implement the fault action until the timeout has elapsed.

Procedure

- Set mA Output Fault Action to the desired value.
The default setting is Downscale.
- If you set mA Output Fault Action to Upscale or Downscale, set mA Output Fault Level as desired.

Options for mA Output Fault Action and mA Output Fault Level

Table 6-4: Options for mA Output Fault Action and mA Output Fault Level

Option	mA output behavior	mA Output Fault Level
Upscale	Goes to the configured fault level	Default: 22.0 mA Range: 21 to 24 mA
Downscale (default)	Goes to the configured fault level	Default: 2.0 mA Range: 1.0 to 3.6 mA
Internal Zero	Goes to the mA output level associated with a process variable value of 0 (zero), as determined by Lower Range Value and Upper Range Value settings	Not applicable

Table 6-4: Options for mA Output Fault Action and mA Output Fault Level (continued)

Option	mA output behavior	mA Output Fault Level
None	Tracks data for the assigned process variable; no fault action	Not applicable

⚠ CAUTION!

If you set mA Output Fault Action or Frequency Output Fault Action to None, be sure to set Digital Communications Fault Action to None. If you do not, the output will not report actual process data, and this may result in measurement errors or unintended consequences for your process.

Restriction

If you set Digital Communications Fault Action to NAN, you cannot set mA Output Fault Action or Frequency Output Fault Action to None. If you try to do this, the transmitter will not accept the configuration.

6.3 Configure the frequency output

The frequency output is used to report a process variable. The frequency output parameters control how the process variable is reported. Your transmitter may have zero or one frequency output: Channel B can be configured as a frequency output or a discrete output.

The frequency output parameters include:

- Frequency Output Process Variable
- Frequency Output Polarity
- Frequency Output Scaling Method
- Frequency Output Maximum Pulse Width
- Frequency Output Fault Action and Frequency Output Fault Value

Important

Whenever you change a frequency output parameter, verify all other frequency output parameters before returning the flowmeter to service. In some situations, the transmitter automatically loads a set of stored values, and these values may not be appropriate for your application.

6.3.1 Configure Frequency Output Process Variable

Display	OFF-LINE MAINT > OFF-LINE CONFIG > IO > CH B > SET FO > FO SRC
ProLink II	ProLink > Configuration > Frequency/Discrete Output > Frequency > Tertiary Variable
ProLink III	Device Tools > Configuration > I/O > Outputs > Frequency Output
Field Communicator	Configure > Manual Setup > Inputs/Outputs > Frequency Output > FO Settings > Third Variable

Overview

Frequency Output Process Variable controls the variable that is reported over the frequency output.

Prerequisites

If you plan to configure the output to report volume flow, ensure that you have set Volume Flow Type as desired: Liquid or Gas Standard Volume.

If you plan to configure an output to report a concentration measurement process variable, ensure that the concentration measurement application is configured so that the desired variable is available.

If you are using the HART variables, be aware that changing the configuration of Frequency Output Process Variable will change the configuration of the HART Tertiary Variable (TV).

Procedure

Set Frequency Output Process Variable as desired.

The default setting is Mass Flow Rate.

Options for Frequency Output Process Variable

The transmitter provides a basic set of options for Frequency Output Process Variable, plus several application-specific options. Different communications tools may use different labels for the options.

Table 6-5: Options for Frequency Output Process Variable

Process variable	Label			
	Display	ProLink II	ProLink III	Field Communicator
Standard				
Mass flow	MFLOW	Mass Flow	Mass Flow Rate	Mass flo
Volume flow	VFLOW	Vol Flow	Volume Flow Rate	Vol flo
Gas standard volume flow rate	GSV F	Gas Std Vol Flow Rate	Gas Standard Volume Flow Rate	Gas vol flo
Petroleum measurement				
Temperature-corrected (standard) volume flow	TCVOL	Std Vol Flow	Volume Flow Rate at Reference Temperature	TC Vol
Concentration measurement				
Standard volume flow	STD V	ED: Std Vol Flow Rate	Volume Flow Rate at Reference Temperature	ED Std Vol flo

Table 6-5: Options for Frequency Output Process Variable (continued)

Process variable	Label			
	Display	ProLink II	ProLink III	Field Communicator
Net mass flow	NET M	ED: Net Mass Flow Rate	Net Mass Flow Rate	ED Net Mass flo
Net volume flow	NET V	ED: Net Vol Flow Rate	Net Volume Flow Rate	ED Net Vol flo

6.3.2 Configure Frequency Output Polarity

Display	OFF-LINE MAINT > OFF-LINE CONFIG > IO > CH B > SET FO > FO POLAR
ProLink II	ProLink > Configuration > Frequency/Discrete Output > Frequency > Freq Output Polarity
ProLink III	Device Tools > Configuration > I/O > Outputs > Frequency Output
Field Communicator	Configure > Manual Setup > Inputs/Outputs > Frequency Output > FO Settings > FO Polarity

Overview

Frequency Output Polarity controls how the output indicates the ON (active) state. The default value, Active High, is appropriate for most applications. Active Low may be required by applications that use low-frequency signals.



Procedure

Set Frequency Output Polarity as desired.

The default setting is Active High.

Options for Frequency Output Polarity

Table 6-6: Options for Frequency Output Polarity

Polarity	Reference voltage (OFF)	Pulse voltage (ON)
Active High 	0	As determined by power supply, pull-up resistor, and load (see the installation manual for your transmitter)
Active Low 	As determined by power supply, pull-up resistor, and load (see the installation manual for your transmitter)	0

6.3.3 Configure Frequency Output Scaling Method

Display	OFF-LINE MAINT > OFF-LINE CONFIG > IO > CH B > SET FO > FO SCALE
ProLink II	ProLink > Configuration > Frequency/Discrete Output > Frequency > Scaling Method
ProLink III	Device Tools > Configuration > I/O > Outputs > Frequency Output
Field Communicator	Configure > Manual Setup > Inputs/Outputs > Frequency Output > FO Scaling

Overview

Frequency Output Scaling Method defines the relationship between output pulse and flow units. Set Frequency Output Scaling Method as required by your frequency receiving device.

Procedure

1. Set Frequency Output Scaling Method.

Option	Description
Frequency=Flow (default)	Frequency calculated from flow rate
Pulses/Unit	A user-specified number of pulses represents one flow unit
Units/Pulse	A pulse represents a user-specified number of flow units

2. Set additional required parameters.
 - If you set Frequency Output Scaling Method to Frequency=Flow, set Rate Factor and Frequency Factor.
 - If you set Frequency Output Scaling Method to Pulses/Unit, define the number of pulses that will represent one flow unit.
 - If you set Frequency Output Scaling Method to Units/Pulse, define the number of units that each pulse will indicate.

Calculate frequency from flow rate

The Frequency=Flow option is used to customize the frequency output for your application when you do not know appropriate values for Units/Pulse or Pulses/Unit.

If you specify Frequency=Flow, you must provide values for Rate Factor and Frequency Factor:

Rate Factor The maximum flow rate that you want the frequency output to report. Above this rate, the transmitter will report A110: Frequency Output Saturated.

Frequency Factor A value calculated as follows:

$$\text{FrequencyFactor} = \frac{\text{RateFactor}}{\text{T}} \times \text{N}$$

where:

T Factor to convert selected time base to seconds

N Number of pulses per flow unit, as configured in the receiving device

The resulting Frequency Factor must be within the range of the frequency output (0 to 10,000 Hz):

- If Frequency Factor is less than 1 Hz, reconfigure the receiving device for a higher pulses/unit setting.
- If Frequency Factor is greater than 10,000 Hz, reconfigure the receiving device for a lower pulses/unit setting.

Tip

If Frequency Output Scale Method is set to Frequency=Flow, and Frequency Output Maximum Pulse Width is set to a non-zero value, Micro Motion recommends setting Frequency Factor to a value below 200 Hz.

Example: Configure Frequency=Flow

You want the frequency output to report all flow rates up to 2000 kg/min.

The frequency receiving device is configured for 10 pulses/kg.

Solution:

$$\text{FrequencyFactor} = \frac{\text{RateFactor}}{T} \times N$$

$$\text{FrequencyFactor} = \frac{2000}{60} \times 10$$

$$\text{FrequencyFactor} = 333.33$$

Set parameters as follows:

- Rate Factor: 2000
- Frequency Factor: 333.33

6.3.4 Configure Frequency Output Maximum Pulse Width

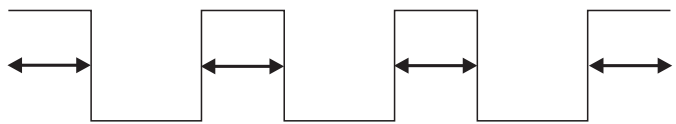
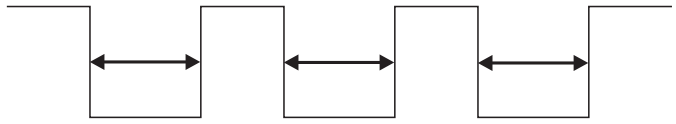
Display	<i>Not available</i>
ProLink II	ProLink > Configuration > Frequency/Discrete Output > Frequency > Freq Pulse Width
ProLink III	Device Tools > Configuration > I/O > Outputs > Frequency Output
Field Communicator	Configure > Manual Setup > Inputs/Outputs > Frequency Output > FO Settings > Max Pulse Width

Overview

Frequency Output Maximum Pulse Width is used to ensure that the duration of the ON signal is great enough for your frequency receiving device to detect.

The ON signal may be the high voltage or 0.0 V, depending on Frequency Output Polarity.

Table 6-7: Interaction of Frequency Output Maximum Pulse Width and Frequency Output Polarity

Polarity	Pulse width
Active High	
Active Low	

Procedure

Set Frequency Output Maximum Pulse Width as desired.

The default value is 277 milliseconds. You can set Frequency Output Maximum Pulse Width to 0 milliseconds or to a value between 0.5 milliseconds and 277.5 milliseconds. The transmitter automatically adjusts the value to the nearest valid value.

Tip

Micro Motion recommends leaving Frequency Output Maximum Pulse Width at the default value. Contact Micro Motion customer service before changing Frequency Output Maximum Pulse Width.

6.3.5

Configure Frequency Output Fault Action and Frequency Output Fault Level

Display	<i>Not available</i>
ProLink II	<ul style="list-style-type: none"> ProLink > Configuration > Frequency/Discrete Output > Frequency > Freq Fault Action ProLink > Configuration > Frequency/Discrete Output > Frequency > Freq Fault Level
ProLink III	Device Tools > Configuration > Fault Processing
Field Communicator	<ul style="list-style-type: none"> Configure > Manual Setup > Inputs/Outputs > Frequency Output > FO Fault Parameters > FO Fault Action Configure > Manual Setup > Inputs/Outputs > Frequency Output > FO Fault Parameters > FO Fault Level

Overview

Frequency Output Fault Action controls the behavior of the frequency output if the transmitter encounters an internal fault condition.

Note

For some faults only: If Last Measured Value Timeout is set to a non-zero value, the transmitter will not implement the fault action until the timeout has elapsed.

Procedure

1. Set Frequency Output Fault Action as desired.
The default value is Downscale (0 Hz).
2. If you set Frequency Output Fault Action to Upscale, set Frequency Fault Level to the desired value.
The default value is 15000 Hz. The range is 10 to 15000 Hz.

Options for Frequency Output Fault Action

Table 6-8: Options for Frequency Output Fault Action

Label	Frequency output behavior
Upscale	Goes to configured Upscale value: <ul style="list-style-type: none"> • Range: 10 Hz to 15000 Hz • Default: 15000 Hz
Downscale	0 Hz
Internal Zero	0 Hz
None (default)	Tracks data for the assigned process variable; no fault action

⚠ CAUTION!

If you set mA Output Fault Action or Frequency Output Fault Action to None, be sure to set Digital Communications Fault Action to None. If you do not, the output will not report actual process data, and this may result in measurement errors or unintended consequences for your process.

Restriction

If you set Digital Communications Fault Action to NAN, you cannot set mA Output Fault Action or Frequency Output Fault Action to None. If you try to do this, the transmitter will not accept the configuration.

6.4 Configure the discrete output

The discrete output is used to report specific flowmeter or process conditions. The discrete output parameters control which condition is reported and how it is reported. Your transmitter may have zero or one discrete output: Channel B can be configured as a frequency output or a discrete output.

The discrete output parameters include:

- Discrete Output Source

- Discrete Output Polarity
- Discrete Output Fault Action

Restriction

Before you can configure the discrete output, you must configure a channel to operate as a discrete output.

Important

Whenever you change a discrete output parameter, verify all other discrete output parameters before returning the flowmeter to service. In some situations, the transmitter automatically loads a set of stored values, and these values may not be appropriate for your application.

6.4.1 Configure Discrete Output Source

Display	OFF-LINE MAINT > OFF-LINE CONFIG > IO > CH B > SET DO > DO SRC
ProLink II	ProLink > Configuration > Frequency/Discrete Output > Discrete Output > DO Assignment
ProLink III	Device Tools > Configuration > I/O > Outputs > Discrete Output
Field Communicator	Configure > Manual Setup > Inputs/Outputs > Discrete Output > DO Assignment

Overview

Discrete Output Source controls which flowmeter condition or process condition is reported via the discrete output.

Procedure

Set Discrete Output Source to the desired option.

The default setting for Discrete Output Source is Flow Direction.

Options for Discrete Output Source

Table 6-9: Options for Discrete Output Source

Option	Label				Condition	Discrete output voltage
	Display	ProLink II	ProLink III	Field Communicator		
Discrete Event 1–5 ⁽¹⁾	D EV x	Discrete Event x	Enhanced Event 1 Enhanced Event 2 Enhanced Event 3	Discrete Event x	ON	Site-specific

(1) Events configured using the enhanced event model.

Table 6-9: Options for Discrete Output Source (continued)

Option	Label				Condition	Discrete output voltage
	Display	ProLink II	ProLink III	Field Communicator		
			Enhanced Event 4 Enhanced Event 5		OFF	0 V
Event 1–2 ⁽²⁾	EVNT1 EVNT2 E1OR2	Event 1 Event 2 Event 1 or Event 2	Event 1 Event 2 Event 1 or Event 2 Status	Event 1 Event 2 Event 1 or Event 2	ON	Site-specific
					OFF	0 V
Flow Switch	FL SW	Flow Switch Indication	Flow Switch Indicator	Flow Switch	ON	Site-specific
					OFF	0 V
Flow Direction	FLDIR	Forward/Reverse Indication	Forward Reverse Indicator	Forward/Reverse	Forward flow	0 V
					Reverse flow	Site-specific
Calibration in Progress	ZERO	Calibration in Progress	Calibration in Progress	Calibration in Progress	ON	Site-specific
					OFF	0 V
Fault	FAULT	Fault Condition Indication	Fault Indication	Fault	ON	Site-specific
					OFF	0 V

Important

This table assumes that Discrete Output Polarity is set to Active High. If Discrete Output Polarity is set to Active Low, reverse the voltage values.

Important

If you assign flow switch to the discrete output, you must also configure Flow Switch Variable, Flow Switch Setpoint, and Hysteresis.

(2) Events configured using the basic event model.

Configure Flow Switch parameters

Display	OFF-LINE MAINT > OFF-LINE CONFG > IO > CH B > SET DO > CONFIG FL SW
ProLink II	<ul style="list-style-type: none"> ProLink > Configuration > Flow > Flow Switch Variable ProLink > Configuration > Flow > Flow Switch Setpoint ProLink > Configuration > Flow > Flow Switch Hysteresis
ProLink III	Device Tools > Configuration > I/O > Outputs > Discrete Output
Field Communicator	<ul style="list-style-type: none"> Configure > Manual Setup > Inputs/Outputs > Discrete Output > Flow Switch Source Configure > Manual Setup > Inputs/Outputs > Discrete Output > Flow Switch Setpoint Configure > Manual Setup > Inputs/Outputs > Discrete Output > Hysteresis

Overview

Flow Switch is used to indicate that the flow rate (measured by the configured flow variable) has moved past the configured setpoint, in either direction. The flow switch is implemented with a user-configurable hysteresis.

Procedure

1. Set Discrete Output Source to Flow Switch, if you have not already done so.
2. Set Flow Switch Variable to the flow variable that you want to use to control the flow switch.
3. Set Flow Switch Setpoint to the value at which the flow switch will be triggered (after Hysteresis is applied).
 - If the flow rate is below this value, the discrete output is ON.
 - If the flow rate is above this value, the discrete output is OFF.
4. Set Hysteresis to the percentage of variation above and below the setpoint that will operate as a deadband.

Hysteresis defines a range around the setpoint within which the flow switch will not change. The default is 5%. The valid range is 0.1% to 10%.

Example: If Flow Switch Setpoint = 100 g/sec and Hysteresis = 5%, and the first measured flow rate is above 100 g/sec, the discrete output is OFF. It will remain OFF unless the flow rate drops below 95 g/sec. If this happens, the discrete output will turn ON, and remain ON until the flow rate rises above 105 g/sec. At this point it turns OFF and will remain OFF until the flow rate drops below 95 g/sec.

6.4.2 Configure Discrete Output Polarity

Display	OFF-LINE MAINT > OFF-LINE CONFIG > IO > CH B > SET DO > DO POLAR
ProLink II	ProLink > Configuration > Frequency/Discrete Output > Discrete Output > DO Polarity
ProLink III	Device Tools > Configuration > I/O > Outputs > Discrete Output
Field Communicator	Configure > Manual Setup > Inputs/Outputs > Discrete Output > DO Polarity

Overview

Discrete outputs have two states: ON (active) and OFF (inactive). Two different voltage levels are used to represent these states. Discrete Output Polarity controls which voltage level represents which state.

Procedure

Set Discrete Output Polarity as desired.

The default setting is Active High.

Options for Discrete Output Polarity

Table 6-10: Options for Discrete Output Polarity



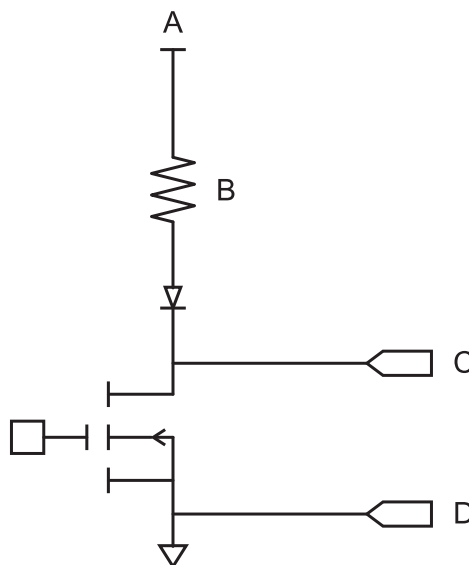
Polarity		Description
Active High		<ul style="list-style-type: none"> When asserted (condition tied to DO is true), the circuit provides a pull-up to 24 V. When not asserted (condition tied to DO is false), the circuit provides 0 V.
Active Low		<ul style="list-style-type: none"> When asserted (condition tied to DO is true), the circuit provides 0 V. When not asserted (condition tied to DO is false), the circuit provides a pull-up to 24 V.

Figure 6-1: Typical discrete output circuit

- A. 24 V (Nom)
- B. 3.2 K Ω
- C. Out+
- D. Out-

6.4.3 Configure Discrete Output Fault Action

Display	<i>Not available</i>
ProLink II	ProLink > Configuration > Frequency/Discrete Output > Discrete Output > DO Fault Action
ProLink III	Device Tools > Configuration > Fault Processing
Field Communicator	Configure > Manual Setup > Inputs/Outputs > Discrete Output > DO Fault Action

Overview

Discrete Output Fault Action controls the behavior of the discrete output if the transmitter encounters an internal fault condition.

Note

For some faults only: If Last Measured Value Timeout is set to a non-zero value, the transmitter will not implement the fault action until the timeout has elapsed.

⚠ CAUTION!

Do not use Discrete Output Fault Action as a fault indicator. If you do, you may not be able to distinguish a fault condition from a normal operating condition. If you want to use the discrete output as a fault indicator, see [Fault indication with the discrete output](#).

Procedure

Set Discrete Output Fault Action as desired.

The default setting is None.

Options for Discrete Output Fault Action**Table 6-11: Options for Discrete Output Fault Action**

Label	Discrete output behavior	
	Polarity=Active High	Polarity=Active Low
Upscale	<ul style="list-style-type: none"> Fault: discrete output is ON (site-specific voltage) No fault: discrete output is controlled by its assignment 	<ul style="list-style-type: none"> Fault: discrete output is OFF (0 V) No fault: discrete output is controlled by its assignment
Downscale	<ul style="list-style-type: none"> Fault: discrete output is OFF (0 V) No fault: discrete output is controlled by its assignment 	<ul style="list-style-type: none"> Fault: discrete output is ON (site-specific voltage) No fault: discrete output is controlled by its assignment
None (default)	Discrete output is controlled by its assignment	

Fault indication with the discrete output

To indicate faults via the discrete output, set parameters as follows:

- Discrete Output Source = Fault
- Discrete Output Fault Action = None

Note

If Discrete Output Source is set to Fault and a fault occurs, the discrete output is always ON. The setting of Discrete Output Fault Action is ignored.

6.5 Configure events

An event occurs when the real-time value of a user-specified process variable moves past a user-defined setpoint. Events are used to provide notification of process changes or to perform specific transmitter actions if a process change occurs.

Your transmitter supports two event models:

- Basic event model
- Enhanced event model

6.5.1 Configure a basic event

Display	<i>Not available</i>
ProLink II	ProLink > Configuration > Events
ProLink III	Device Tools > Configuration > Events > Basic Events
Field Communicator	<i>Not available</i>

Overview

A basic event is used to provide notification of process changes. A basic event occurs (is ON) if the real-time value of a user-specified process variable moves above (HI) or below (LO) a user-defined setpoint. You can define up to two basic events. Event status can be queried via digital communications, and a discrete output can be configured to report event status.

Procedure

1. Select the event that you want to configure.
2. Specify Event Type.

Options	Description
HI	$x > A$ The event occurs when the value of the assigned process variable (x) is greater than the setpoint (Setpoint A), endpoint not included.
LO	$x < A$ The event occurs when the value of the assigned process variable (x) is less than the setpoint (Setpoint A), endpoint not included.

3. Assign a process variable to the event.
4. Set a value for Setpoint A.
5. (Optional) Configure a discrete output to switch states in response to the event status.

6.5.2 Configure an enhanced event

Display	<i>Not available</i>
ProLink II	ProLink > Configuration > Discrete Events
ProLink III	Device Tools > Configuration > Events > Enhanced Events
Field Communicator	Configure > Alert Setup > Discrete Events

Overview

An enhanced event is used to provide notification of process changes and, optionally, to perform specific transmitter actions if the event occurs. An enhanced event occurs (is ON) if the real-time value of a user-specified process variable moves above (HI) or below (LO) a user-defined setpoint, or in range (IN) or out of range (OUT) with respect to two user-defined setpoints. You can define up to five enhanced events. For each enhanced event, you can assign one or more actions that the transmitter will perform if the enhanced event occurs.

Procedure

1. Select the event that you want to configure.
2. Specify Event Type.

Options	Description
HI	$x > A$ The event occurs when the value of the assigned process variable (x) is greater than the setpoint (Setpoint A), endpoint not included.
LO	$x < A$ The event occurs when the value of the assigned process variable (x) is less than the setpoint (Setpoint A), endpoint not included.
IN	$A \leq x \leq B$ The event occurs when the value of the assigned process variable (x) is "in range," that is, between Setpoint A and Setpoint B, endpoints included.
OUT	$x \leq A$ or $x \geq B$ The event occurs when the value of the assigned process variable (x) is "out of range," that is, less than Setpoint A or greater than Setpoint B, endpoints included.

3. Assign a process variable to the event.
4. Set values for the required setpoints.
 - For HI and LO events, set Setpoint A.
 - For IN and OUT events, set Setpoint A and Setpoint B.
5. (Optional) Configure a discrete output to switch states in response to the event status.
6. (Optional) Specify the action or actions that the transmitter will perform when the event occurs.
 - With the display: OFF-LINE MAINT > OFF-LINE CONFIG > IO > CH C > SET DI > DI ACT
 - With ProLink II: ProLink > Configuration > Discrete Input
 - With ProLink III: Device Tools > Configuration > I/O > Action Assignment
 - With the Field Communicator: Configure > Alert Setup > Discrete Events > Assign Discrete Action

Options for Enhanced Event Action

Table 6-12: Options for Enhanced Event Action

Action	Label			
	Display	ProLink II	ProLink III	Field Communicator
Standard				
None (default)	NONE	None	None	None
Start sensor zero	START ZERO	Start Sensor Zero	Start Sensor Zero	Perform auto zero
Start/stop all totalizers	START STOP	Start/Stop All Totalization	Start/Stop All Totalization	Start/stop totals
Reset mass total	RESET MASS	Reset Mass Total	Reset Mass Total	Reset mass total
Reset volume total	RESET VOL	Reset Volume Total	Reset Volume Total	Reset volume total
Reset gas standard volume total	RESET GSVT	Reset Gas Std Volume Total	Reset Gas Std Volume Total	Reset gas standard volume total
Reset all totals	RESET ALL	Reset All Totals	Reset All Totals	Reset totals
Petroleum measurement				
Reset temperature-corrected volume total	TCVOL	Reset API Ref Vol Total	Reset Volume Total at Reference Temperature	Reset corrected volume total
Concentration measurement				
Reset CM reference volume total	RESET STD V	Reset CM Ref Vol Total	Reset Volume Total at Reference Temperature	<i>Not available</i>
Reset CM net mass total	RESET NET M	Reset CM Net Mass Total	Reset Net Mass Total	<i>Not available</i>
Reset CM net volume total	RESET NET V	Reset CM Net Vol Total	Reset Net Volume Total	<i>Not available</i>
Increment CM matrix	INCr CURVE	Increment Current CM Curve	Increment Concentration Matrix	<i>Not available</i>
Meter verification				
Start meter verification test	START VERIFY	Start Meter Verification	Start Meter Verification	<i>Not available</i>

⚠ CAUTION!

Before assigning actions to an enhanced event or discrete input, check the status of the event or the remote input device. If it is ON, all assigned actions will be performed when the new configuration is implemented. If this is not acceptable, wait until an appropriate time to assign actions to the event or discrete input.

6.6 Configure digital communications

The digital communications parameters control how the transmitter will communicate using digital communications.

Your transmitter supports the following types of digital communications:

- HART/Bell 202 over the primary mA terminals
- HART/RS-485 over the RS-485 terminals
- Modbus/RS-485 over the RS-485 terminals
- Modbus RTU via the service port

Note

The service port responds automatically to a wide range of connection requests. It is not configurable.

6.6.1 Configure HART/Bell 202 communications

Display	OFF-LINE MAINT > OFF-LINE CONFIG > COMM
ProLink II	ProLink > Configuration > Device > Digital Comm Settings
ProLink III	Device Tools > Configuration > Communications > Communications (HART)
Field Communicator	Configure > Manual Setup > Inputs/Outputs > Communications > HART Communications

Overview

HART/Bell 202 communications parameters support HART communication with the transmitter's primary mA terminals over a HART/Bell 202 network.

The HART/Bell 202 communications parameters include:

- HART Address (Polling Address)
- Loop Current Mode (ProLink II) or mA Output Action (ProLink III)
- Burst Parameters (optional)
- HART Variables (optional)

Procedure

1. Set HART Address to a unique value on your network.

Valid address values are between 0 and 15. The default address (0) is typically used unless you are in a multidrop environment.

Tip

Devices using HART protocol to communicate with the transmitter may use either HART Address or HART Tag (Software Tag) to identify the transmitter. Configure either or both, as required by your other HART devices.

2. Ensure Loop Current Mode (mA Output Action) is configured appropriately.

Options	Description
Enabled	The primary mA output reports process data as configured.
Disabled	The primary mA output is fixed at 4 mA and does not report process data.

Important

If you use ProLink II or ProLink III to set HART Address to 0, the program automatically enables Loop Current Mode. If you use ProLink II or ProLink III to set HART Address to any other value, the program automatically disables Loop Current Mode. This is designed to make it easier to configure the transmitter for legacy behavior. Always verify Loop Current Mode after setting HART Address.

3. (Optional) Enable and configure Burst Parameters.

Tip

In typical installations, burst mode is disabled. Enable burst mode only if another device on the network requires burst mode communication.

4. (Optional) Configure HART Variables.

Configure burst parameters

Display	<i>Not available</i>
ProLink II	ProLink > Configuration > Device > Burst Setup
ProLink III	Device Tools > Configuration > Communications > Communications (HART)
Field Communicator	Configure > Manual Setup > Inputs/Outputs > Communications > Set Up Burst Mode

Overview

Burst mode is a mode of communication during which the transmitter regularly broadcasts HART digital information over the mA output. The burst parameters control the information that is broadcast when burst mode is enabled.

Tip

In typical installations, burst mode is disabled. Enable burst mode only if another device on the network requires burst mode communication.

Procedure

1. Enable Burst Mode.
2. Set Burst Mode Output as desired.

Label			Description
ProLink II	ProLink III	Field Communicator	
Primary Variable	Source (Primary Variable)	PV	The transmitter sends the primary variable (PV) in the configured measurement units in each burst (e.g., 14.0 g/sec, 13.5 g/sec, 12.0 g/sec).
PV current & % of range	Primary Variable (Percent Range/Current)	% range/current	The transmitter sends the PV's percent of range and the PV's actual mA level in each burst (e.g., 25%, 11.0 mA).
Dynamic vars & PV current	Process Variables/Current	Process variables/current	The transmitter sends PV, SV, TV, and QV values in measurement units and the PV's actual milliamp reading in each burst (e.g., 50 g/sec, 23 °C, 50 g/sec, 0.0023 g/cm ³ , 11.8 mA).
Transmitter vars	Transmitter variables	Fld dev var	The transmitter sends four user-specified process variables in each burst.

3. Ensure that the burst output variables are set appropriately.
 - If you set Burst Mode Output to send four user-specified variables, set the four process variables to be sent in each burst.
 - If you set Burst Mode Output to any other option, ensure that the HART variables are set as desired.

Configure HART variables (PV, SV, TV, QV)

Display	<i>Not available</i>
ProLink II	ProLink > Configuration > Variable Mapping
ProLink III	Device Tools > Configuration > Communications > Communications (HART)
Field Communicator	Configure > Manual Setup > Inputs/Outputs > Variable Mapping

Overview

The HART variables are a set of four variables predefined for HART use. The HART variables include the Primary Variable (PV), Secondary Variable (SV), Tertiary Variable (TV), and Quaternary Variable (QV). You can assign specific process variables to the HART variables, and then use standard HART methods to read or broadcast the assigned process data.

Options for HART variables

Table 6-13: Options for HART variables

Process variable	Primary Variable (PV)	Secondary Variable (SV)	Third Variable (TV)	Fourth Variable (QV)
Standard				
Mass flow rate	✓	✓	✓	✓
Line (Gross) Volume flow rate	✓	✓	✓	✓
Temperature	✓	✓		✓
Density	✓	✓		✓
Drive gain	✓	✓		✓
Mass total				✓
Line (Gross) Volume total				✓
Mass inventory				✓
Line (Gross) Volume inventory				✓
Tube frequency				✓
Meter temperature				✓
LPO amplitude				✓
RPO amplitude				✓
Board temperature				✓
External pressure	✓	✓		✓
External temperature	✓	✓		✓
Gas standard volume flow rate	✓	✓	✓	✓
Gas standard volume total				✓
Gas standard volume inventory				✓
Live zero				✓
Petroleum measurement				
API density	✓	✓		✓
API volume flow rate	✓	✓	✓	✓
API volume total				✓
API volume inventory				✓
API average density	✓	✓		✓
API average temperature	✓	✓		✓
API CTL				✓
Concentration measurement				
ED density at reference temperature	✓	✓		✓
ED specific gravity	✓	✓		✓

Table 6-13: Options for HART variables (continued)

Process variable	Primary Variable (PV)	Secondary Variable (SV)	Third Variable (TV)	Fourth Variable (QV)
ED standard volume flow rate	✓	✓	✓	✓
ED standard volume total				✓
ED standard volume inventory				✓
ED net mass flow rate	✓	✓	✓	✓
ED net mass total				✓
ED net mass inventory				✓
ED net volume flow rate	✓	✓	✓	✓
ED net volume total				✓
ED net volume inventory				✓
ED concentration	✓	✓		✓
ED Baume	✓	✓		✓

Interaction of HART variables and transmitter outputs

The HART variables are automatically reported through specific transmitter outputs. They may also be reported through HART burst mode, if enabled on your transmitter.

Table 6-14: HART variables and transmitter outputs

HART variable	Reported via	Comments
Primary Variable (PV)	Primary mA output	If one assignment is changed, the other is changed automatically, and vice versa.
Secondary Variable (SV)	Not associated with an output	The SV must be configured directly, and the value of the SV is available only via digital communications.
Tertiary Variable (TV)	Frequency output (if present on your transmitter)	If one assignment is changed, the other is changed automatically, and vice versa. If your transmitter does not have a frequency output, the TV must be configured directly, and the value of the TV is available only via digital communications.
Quaternary Variable (QV)	Not associated with an output	The QV must be configured directly, and the value of the QV is available only via digital communications.

6.6.2 Configure HART/RS-485 communications

Display	OFF-LINE MAINT > OFF-LINE CONFIG > COMM
ProLink II	ProLink > Configuration > Device > Digital Comm Settings > HART Address ProLink > Configuration > RS-485
ProLink III	Device Tools > Configuration > Communications > Communications (HART)
Field Communicator	Configure > Manual Setup > Inputs/Outputs > Communications > HART Communications

Overview

HART/RS-485 communications parameters support HART communication with the transmitter's RS-485 terminals.

HART/RS-485 communication parameters include:

- Protocol
- HART Address (Polling Address)
- Parity, Stop Bits, and Baud Rate

Restriction

The transmitter uses the same RS-485 terminals for HART/RS-485, Modbus RTU, and Modbus ASCII communications. All RS-485 connection requests must use the same protocol and connection parameters that are configured in the transmitter.

Procedure

1. Set Protocol to HART RS-485.
2. Set Baud Rate to match the baud rate that will be used by your HART master.
3. Set Parity to match the parity that will be used by your HART master.
4. Set Stop Bits to match the stop bits setting that will be used by your HART master.
5. Set HART Address to a unique value on your network.

Valid address values are between 0 and 15. The default address (0) is typically used unless you are in a multidrop environment.

Tip

Devices using HART protocol to communicate with the transmitter may use either HART Address or HART Tag (Software Tag) to identify the transmitter. Configure either or both, as required by your other HART devices.

6.6.3 Configure Modbus/RS-485 communications

Display	OFF-LINE MAINT > OFF-LINE CONFIG > COMM
ProLink II	ProLink > Configuration > Device > Digital Comm Settings
ProLink III	Device Tools > Configuration > Communications > RS-485 Terminals
Field Communicator	Configure > Manual Setup > Inputs/Outputs > Communications > Set Up RS-485 Port

Overview

Modbus/RS-485 communications parameters control Modbus communication with the transmitter's RS-485 terminals.

Modbus/RS-485 communications parameters include:

- Disable Modbus ASCII
- Protocol
- Modbus Address (Slave Address)
- Parity, Stop Bits, and Baud Rate
- Floating-Point Byte Order
- Additional Communications Response Delay

Restriction

To configure Floating-Point Byte Order or Additional Communications Response Delay, you must use ProLink II.

Procedure

1. Set Disable Modbus ASCII as desired.

Support for Modbus ASCII limits the set of addresses that are available for the transmitter's Modbus address.

Modbus ASCII support	Available Modbus addresses
Disabled	1–127, excluding 111 (111 is reserved to the service port)
Enabled	1–15, 32–47, 64–79, and 96–110

2. Set Protocol to match the protocol used by your Modbus/RS-485 host.

Options	Description
Modbus RTU (default)	8-bit communications
Modbus ASCII	7-bit communications

If support for Modbus ASCII is disabled, you must use Modbus RTU.

3. Set Modbus Address to a unique value on the network.

4. Set Parity, Stop Bits, and Baud Rate as appropriate for your network.
5. Set Floating-Point Byte Order to match the byte order used by your Modbus host.

Code	Byte order
0	1-2 3-4
1	3-4 1-2
2	2-1 4-3
3	4-3 2-1

See [Table 6-15](#) for the bit structure of bytes 1, 2, 3, and 4.

Table 6-15: Bit structure of floating-point bytes

Byte	Bits	Definition
1	SEEEEEEE	S=Sign E=Exponent
2	EMMMMMMM	E=Exponent M=Mantissa
3	MMMMMMMM	M=Mantissa
4	MMMMMMMM	M=Mantissa

6. (Optional) Set Additional Communications Response Delay in “delay units.”

A delay unit is 2/3 of the time required to transmit one character, as calculated for the port currently in use and the character transmission parameters. Valid values range from 1 to 255.

Additional Communications Response Delay is used to synchronize Modbus communications with hosts that operate at a slower speed than the transmitter. The value specified here will be added to each response the transmitter sends to the host.

Tip

Do not set Additional Communications Response Delay unless required by your Modbus host.

6.6.4 Configure Digital Communications Fault Action

Display	<i>Not available</i>
ProLink II	ProLink > Configuration > Device > Digital Comm Settings > Digital Comm Fault Setting
ProLink III	Device Tools > Configuration > Fault Processing
Field Communicator	Configure > Alert Setup > I/O Fault Actions > Comm Fault Action

Overview

Digital Communications Fault Action specifies the values that will be reported via digital communications if the transmitter encounters an internal fault condition.

Procedure

Set Digital Communications Fault Action as desired.

The default setting is None.

Options for Digital Communications Fault Action

Table 6-16: Options for Digital Communications Fault Action

Label			Description
ProLink II	ProLink III	Field Communicator	
Upscale	Upscale	Upscale	<ul style="list-style-type: none"> Process variable values indicate that the value is greater than the upper sensor limit. Totalizers stop incrementing.
Downscale	Downscale	Downscale	<ul style="list-style-type: none"> Process variable values indicate that the value is greater than the upper sensor limit. Totalizers stop incrementing.
Zero	Zero	IntZero-All 0	<ul style="list-style-type: none"> Flow rate variables go to the value that represents a flow rate of 0 (zero). Density is reported as 0. Temperature is reported as 0 °C, or the equivalent if other units are used (e.g., 32 °F). Drive gain is reported as measured. Totalizers stop incrementing.
Not-a-Number (NaN)	Not a Number	Not-a-Number	<ul style="list-style-type: none"> Process variables are reported as IEEE NaN. Drive gain is reported as measured. Modbus scaled integers are reported as Max Int. Totalizers stop incrementing.
Flow to Zero	Flow to Zero	IntZero-Flow 0	<ul style="list-style-type: none"> Flow rates are reported as 0. Other process variables are reported as measured. Totalizers stop incrementing.
None (default)	None	None (default)	<ul style="list-style-type: none"> All process variables are reported as measured. Totalizers increment if they are running.

 **CAUTION!**

If you set mA Output Fault Action or Frequency Output Fault Action to None, be sure to set Digital Communications Fault Action to None. If you do not, the output will not report actual process data, and this may result in measurement errors or unintended consequences for your process.

Restriction

If you set Digital Communications Fault Action to NAN, you cannot set mA Output Fault Action or Frequency Output Fault Action to None. If you try to do this, the transmitter will not accept the configuration.

7 Completing the configuration

Topics covered in this chapter:

- *Test or tune the system using sensor simulation*
- *Back up transmitter configuration*
- *Enable write-protection on the transmitter configuration*

7.1 Test or tune the system using sensor simulation

Use sensor simulation to test the system's response to a variety of process conditions, including boundary conditions, problem conditions, or alarm conditions, or to tune the loop.

Restriction

Sensor simulation is available only on flowmeters with the enhanced core processor.

Prerequisites

Before enabling sensor simulation, ensure that your process can tolerate the effects of the simulated process values.

Procedure

1. Navigate to the sensor simulation menu.

Communications tool	Menu path
Display	<i>Not available</i>
ProLink II	ProLink > Configuration > Sensor Simulation
ProLink III	Device Tools > Diagnostics > Testing > Sensor Simulation
Field Communicator	Service Tools > Simulate > Simulate Sensor

2. Enable sensor simulation.
3. For mass flow, set Wave Form as desired and enter the required values.

Option	Required values
Fixed	Fixed Value
Sawtooth	Period Minimum Maximum

Option	Required values
Sine	Period Minimum Maximum

- For density, set Wave Form as desired and enter the required values.

Option	Required values
Fixed	Fixed Value
Sawtooth	Period Minimum Maximum
Sine	Period Minimum Maximum

- For temperature, set Wave Form as desired and enter the required values.

Option	Required values
Fixed	Fixed Value
Sawtooth	Period Minimum Maximum
Sine	Period Minimum Maximum

- Observe the system response to the simulated values and make any appropriate changes to the transmitter configuration or to the system.
- Modify the simulated values and repeat.
- When you have finished testing or tuning, disable sensor simulation.

7.1.1 Sensor simulation

Sensor simulation allows you to test the system or tune the loop without having to create the test conditions in your process. When sensor simulation is enabled, the transmitter reports the simulated values for mass flow, density, and temperature, and takes all appropriate actions. For example, the transmitter might apply a cutoff, activate an event, or post an alarm.

When sensor simulation is enabled, the simulated values are stored in the same memory locations used for process data from the sensor. The simulated values are then used throughout transmitter functioning. For example, sensor simulation will affect:

- All mass flow rate, temperature, and density values shown on the display or reported via outputs or digital communications
- The mass total and mass inventory values
- All volume calculations and data, including reported values, volume totals, and volume inventories
- All mass, temperature, density, or volume values logged to Data Logger

Sensor simulation does not affect any diagnostic values.

Unlike actual mass flow rate and density values, the simulated values are not temperature-compensated (adjusted for the effect of temperature on the sensor's flow tubes).

7.2 Back up transmitter configuration

ProLink II and ProLink III provide a configuration upload/download function which allows you to save configuration sets to your PC. This allows you to back up and restore your transmitter configuration. It is also a convenient way to replicate a configuration across multiple devices.

Prerequisites

One of the following:

- An active connection from ProLink II
- An active connection from ProLink III

Restriction

This function is not available with any other communications tools.

Procedure

- To back up the transmitter configuration using ProLink II:
 1. Choose File > Load from Xmtr to File.
 2. Specify a name and location for the backup file, and click Save.
 3. Select the options that you want to include in the backup file, and click Download Configuration.
- To back up the transmitter configuration using ProLink III:
 1. Choose Device Tools > Configuration Transfer > Save or Load Configuration Data.
 2. In the Configuration groupbox, select the configuration data you want to save.
 3. Click Save, then specify a file name and location on your computer.
 4. Click Start Save.

The backup file is saved to the specified name and location. It is saved as a text file and can be read using any text editor.

7.3 Enable write-protection on the transmitter configuration

Display	OFF-LINE MAINT > CONFIG > LOCK
ProLink II	ProLink > Configuration > Device > Enable Write Protection
ProLink III	Device Tools > Configuration > Write-Protection
Field Communicator	Configure > Manual Setup > Info Parameters > Transmitter Info > Write Protect

Overview

If the transmitter is write-protected, the configuration is locked and nobody can change it until it is unlocked. This prevents accidental or unauthorized changes to the transmitter configuration parameters.

8 Set up the Weights & Measures application

Topics covered in this chapter:

- [Weights & Measures application](#)
- [Set up the Weights & Measures application using ProLink II](#)
- [Set up the Weights & Measures application using ProLink III](#)

Information in this chapter is applicable only if your transmitter was ordered with the Weights & Measures application.

8.1 Weights & Measures application

The Weights & Measures application is used to provide process data that is legal for custody transfer applications when an approved method is used to read or obtain the measurement.

Regulatory agencies

When installed, configured, and used as recommended by Micro Motion, the Weights & Measures application is certified by the following regulatory agencies:

- NTEP (National Type Evaluation Program). NTEP requirements apply in the U.S.A. and Canada.
- OIML (Organization of Legal Metrology). OIML requirements apply in all other world areas.

Depending on the regulatory agency that governs your installation, different setup, configuration, and operation methods are applicable.

Secured vs. unsecured

When the Weights & Measures application is installed, the transmitter is always “secured” or “unsecured.” The transmitter leaves the factory in unsecured mode, with Status Alarm A027: Security Breach active. Additionally, flow measurement may be disabled. Measurement data from an unsecured transmitter cannot be used for custody transfer applications.

To clear the alarm and enable flow measurement, you must configure the Weights & Measures application and secure the transmitter. When the transmitter is secured, the alarm is cleared and flow measurement is enabled automatically.

Security types and requirements

Before using the transmitter for Weights & Measures measurement, both metrological security and physical security must be implemented.

Metrological security	<p>Metrological security protects the transmitter from all changes that would affect measurement. This includes changes to configuration and some maintenance procedures.</p> <p>Micro Motion implements metrological security via “software security.” Software security is a setting inside the transmitter that programmatically disables the prohibited actions. Software security can be enabled or disabled from ProLink II and ProLink III. Practically speaking, software security provides complete protection against unauthorized changes or actions.</p>
Physical security	<p>Physical security is implemented by a seal installed by a certified Weights & Measures inspector. The seal prevents access to the service port terminals.</p> <p>Although the seal can be broken easily, it cannot be replaced by anybody other than a Weights & Measures inspector. This makes it easy to detect that security has been violated. If the seal is not intact, transmitter measurements are not valid for custody transfer.</p>

Configuration methods

You must use ProLink II or ProLink III and a service port connection to configure the Weights & Measures parameters.

8.2 Set up the Weights & Measures application using ProLink II

When your transmitter is set up to comply with OIML or NTEP requirements, and the transmitter is “secured,” selected measurement data from the transmitter is approved for Weights & Measures applications.

Prerequisites

Important

Review the Weights & Measures requirements for your location and ensure that you are complying with all local requirements as well as the OIML or NTEP requirements.

If necessary for your installation, arrange for a site visit by a certified Weights & Measures inspector, and ensure that the inspector is present for the appropriate portions of this procedure.

Ensure that the transmitter is ready to be secured, i.e., it is configured as desired and you have performed all appropriate tests and adjustments. After the transmitter is secured, you cannot make any changes to configuration, many maintenance actions are disallowed, and some operator actions are disallowed.

Procedure

1. Make a service port connection from ProLink II to your transmitter.
2. Navigate to the Weights & Measures menu: ProLink > Configuration > System.

3. Set Approval to the appropriate regulatory agency for your application.

Option	Description
NTEP	Regulatory agency for the U.S.A. and Canada
OIML	Regulatory agency for all other world areas

4. Set Totalizer Reset Options as desired.

Option	Description
Not Resettable from Display and Digital Comm	When the transmitter is secured, totalizers cannot be reset from either the transmitter display or digital communications.
Resettable from Digital Comm Only	When the transmitter is secured, you must use digital communications to reset the totalizers.
Resettable from Display and Digital Comm	When the transmitter is secured, you can use either the transmitter display or digital communications to reset the totalizers.
Resettable from Display Only	When the transmitter is secured, you must use the transmitter display to reset the totalizers.

“Digital communications” refers to any method that uses Modbus or HART communications to interact with the transmitter. This includes ProLink II, ProLink III, the Field Communicator, and any host.

5. If required for your installation, configure your transmitters for two frequency outputs and set them to operate in Quadrature mode.
- Choose ProLink > Configuration > Channel.
 - Set Channel B Type Assignment to Frequency Output and click Apply.
 - Set Channel C Type Assignment to Frequency Output and click Apply.
 - Choose ProLink > Configuration > Frequency and set Freq Output Mode to Quadrature.
6. If required for your installation, enable Alarm Menu Password for the display: ProLink > Configuration > Display.

Alarm Menu Password is required under German law for PTB-type approval for gas applications, and may be required in other locations or for other application types.

7. If required for your installation, read and record the firmware checksum values for the transmitter and the core processor: ProLink > Configuration > Device.

The checksum values for the transmitter firmware and the core processor firmware must be read during meter commissioning to meet Weights & Measures requirements for gas applications in Germany. They may also be useful for MID/Welmec 7.2 test reports.

8. If required for your installation, configure Field Verification Zero (FVZ) as a display variable, then observe and record the current value of FVZ: ProLink > Configuration > Display.

FVZ is a diagnostic variable that monitors the zero value over a period of 3 minutes. It must be read during meter commissioning to comply with MID requirements for Weights & Measures applications in Measuring Instrument Directive (MID) 2004/22/EC. Refer to your Standard Operating Procedures documentation for detailed instructions.

9. Enable software security:
 - a. Choose Plug-ins > Enable/Disable Custody Transfer.
 - b. Click Enable Custody Transfer.

Important

Depending on local requirements, this step may need to be witnessed by a certified Weights & Measures inspector.

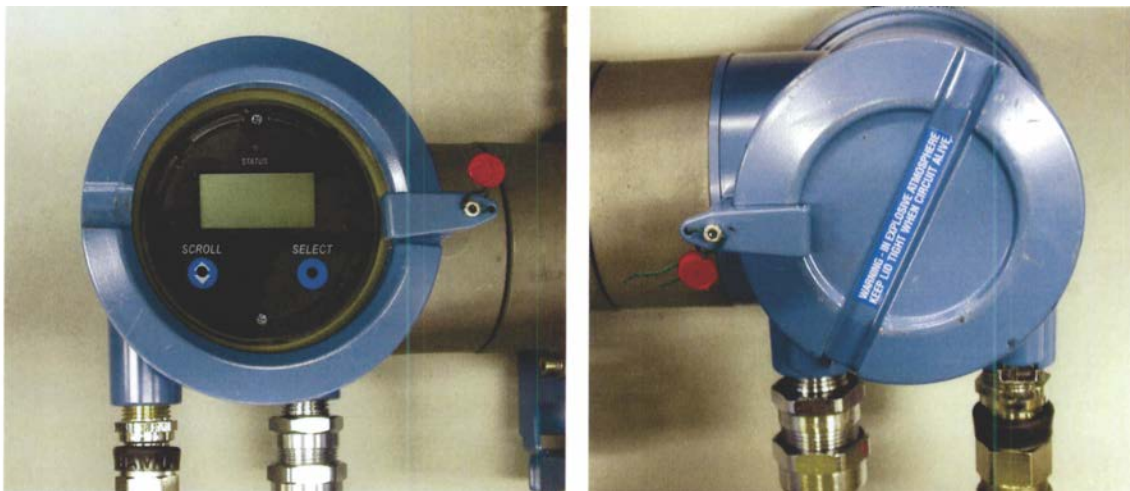
After this step, the transmitter is in a condition of metrological security (measurement security). The transmitter performs the following actions:

- Securing all measurement parameters. You can read the current configurations but you cannot change them.
 - Clearing Status Alarm A027: Security Breach.
10. Install the physical seal.

Important

In most installations, the physical seal is a wire seal that must be installed by a certified Weights & Measures inspector. The seal is provided by the inspector. The physical seal is inserted through the locking clamps on the transmitter (if available on your transmitter).

Figure 8-1: Example of locking clamp and seal on transmitter



8.3 Set up the Weights & Measures application using ProLink III

When your transmitter is set up to comply with OIML or NTEP requirements, and the transmitter is “secured,” selected measurement data from the transmitter is approved for Weights & Measures applications.

Prerequisites

Important

Review the Weights & Measures requirements for your location and ensure that you are complying with all local requirements as well as the OIML or NTEP requirements.

If necessary for your installation, arrange for a site visit by a certified Weights & Measures inspector, and ensure that the inspector is present for the appropriate portions of this procedure.

Ensure that the transmitter is ready to be secured, i.e., it is configured as desired and you have performed all appropriate tests and adjustments. After the transmitter is secured, you cannot make any changes to configuration, many maintenance actions are disallowed, and some operator actions are disallowed.

Procedure

1. Make a service port connection from ProLink III to your transmitter.
2. Choose Device Tools > Configuration > Weights & Measures and set Regulatory Agency to the appropriate regulatory agency for your application.

Option	Description
NTEP	Regulatory agency for the U.S.A. and Canada
OIML	Regulatory agency for all other world areas

3. Choose Device Tools > Configuration > Totalizer Control Methods and set totalizer control methods as desired.

Parameter	Option
Reset Totalizers from Display	<ul style="list-style-type: none"> • Enabled: You can reset totalizers from the display, whether or not the transmitter is secured. • Disabled: You can reset totalizers from the display only when the transmitter is unsecured.
Reset Totalizers via Remote Communications	<ul style="list-style-type: none"> • Enabled: You can reset totalizers using digital communications, whether or not the transmitter is secured. • Disabled: You can reset totalizers using digital communications only when the transmitter is unsecured.

“Digital communications” refers to any method that uses Modbus or HART communications to interact with the transmitter. This includes ProLink II, ProLink III, the Field Communicator, and any host.

4. If required for your installation, configure your transmitters for two frequency outputs and set them to operate in Quadrature mode.
 - a. Choose Device Tools > Configuration > I/O > Channels.
 - b. For Channel B, set Channel Type to Frequency Output and click Apply.
 - c. For Channel C, set Channel Type to Frequency Output and click Apply.
 - d. Choose Device Tools > Configuration > I/O > Outputs > Frequency Output Mode and select Quadrature.
5. If required for your installation, choose Device Tools > Configuration > Transmitter Display > Display Security, then enable and configure a password for the alarm menu.

Security for the alarm menu is required under German law for PTB-type approval for gas applications.

6. If required for your installation, choose Device Tools > Device Information, then read and record the firmware checksum values for the transmitter and the core processor.

The checksum values for the transmitter firmware and the core processor firmware must be read during meter commissioning to meet Weights & Measures requirements for gas applications in Germany. They may also be useful for MID/Welmec 7.2 test reports.

7. If required for your installation, monitor the zero value of your system:
 - a. Choose Device Tools > Configuration > Transmitter Display > Display Variables and configure Field Verification Zero (FVZ) as a display variable.
 - b. At the transmitter display, read and record the current value of FVZ.

FVZ is a diagnostic variable that monitors the zero value over a period of 3 minutes. It must be read during meter commissioning to comply with MID requirements for Weights & Measures applications in Measuring Instrument Directive (MID) 2004/22/EC. Refer to your Standard Operating Procedures documentation for detailed instructions.

8. Enable software security: Device Tools > Configuration > Weights & Measures > Software Security.

Important

Depending on local requirements, this step may need to be witnessed by a certified Weights & Measures inspector.

After this step, the transmitter is in a condition of metrological security (measurement security). The transmitter performs the following actions:

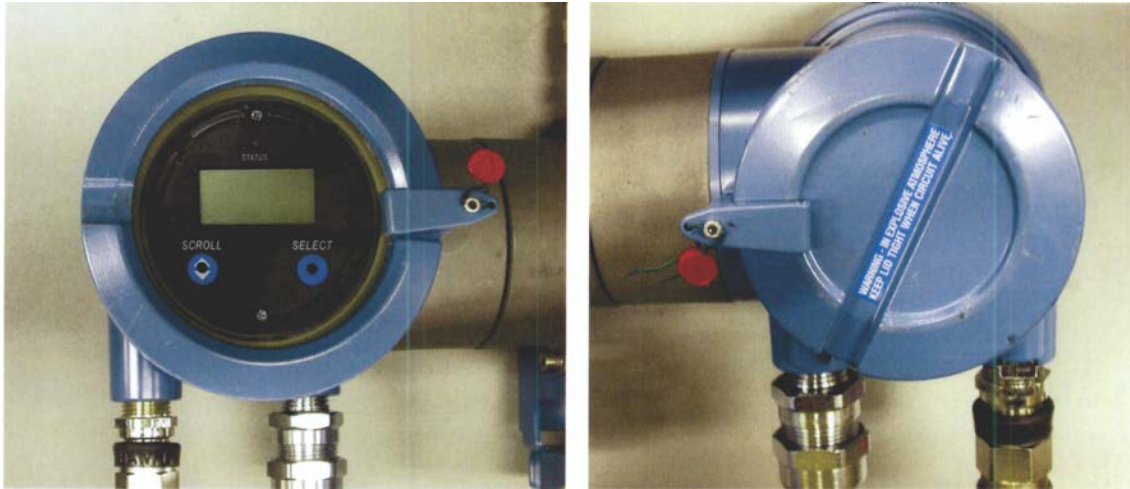
- Securing all measurement parameters. You can read the current configurations but you cannot change them.
- Clearing Status Alarm A027: Security Breach.

9. Install the physical seal.

Important

In most installations, the physical seal is a wire seal that must be installed by a certified Weights & Measures inspector. The seal is provided by the inspector. The physical seal is inserted through the locking clamps on the transmitter (if available on your transmitter).

Figure 8-2: Example of locking clamp and seal on transmitter



Part III

Operations, maintenance, and troubleshooting

Chapters covered in this part:

- *Transmitter operation*
- *Operate the transmitter with the Weights & Measures application*
- *Measurement support*
- *Troubleshooting*

9 Transmitter operation

Topics covered in this chapter:

- *Record the process variables*
- *View process variables*
- *View transmitter status using the status LED*
- *View and acknowledge status alarms*
- *Read totalizer and inventory values*
- *Start and stop totalizers and inventories*
- *Reset totalizers*
- *Reset inventories*

9.1 Record the process variables

Micro Motion suggests that you make a record of specific process variable measurements, including the acceptable range of measurements, under normal operating conditions. This data will help you recognize when the process variables are unusually high or low, and may help you better diagnose and troubleshoot application issues.

Procedure

Record the following process variables, under normal operating conditions:

Process variable	Measurement		
	Typical average	Typical high	Typical low
Flow rate			
Density			
Temperature			
Tube frequency			
Pickoff voltage			
Drive gain			

9.2 View process variables

Display	Scroll to the desired process variable. If AutoScroll is enabled, you can wait until the process variable is displayed. See Section 9.2.1 for more information.
ProLink II	ProLink > Process Variables ProLink > API process variables (petroleum measurement application) ProLink > CM process variables (concentration measurement application)
ProLink III	View the desired variable on the main screen under Process Variables. See Section 9.2.2 for more information.
Field Communicator	Overview > Shortcuts > Variables > Process Variables

Overview

Process variables provide information about the state of the process fluid, such as flow rate, density, and temperature, as well as running totals. Process variables can also provide data about flowmeter operation, such as drive gain and pickoff voltage. This information can be used to understand and troubleshoot your process.

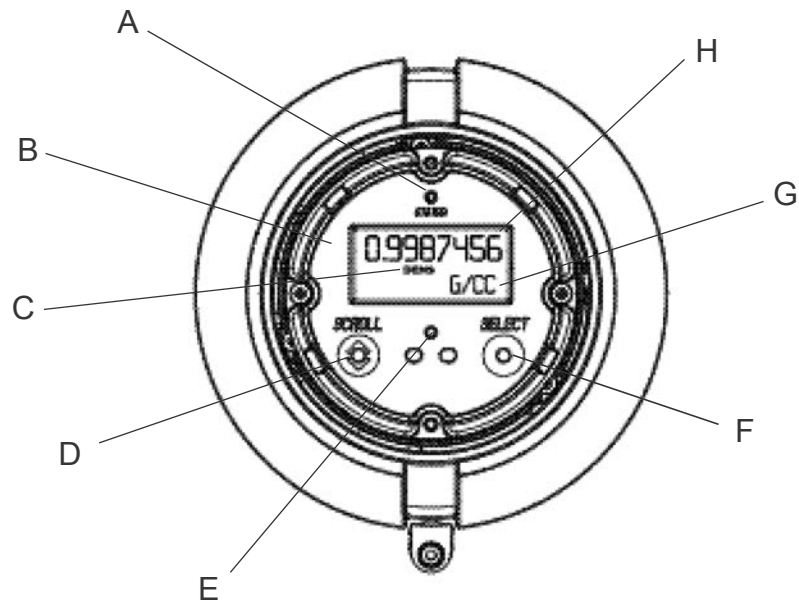
9.2.1 View process variables using the display

View the desired process variable(s).

If you are using the transmitter display, by default the display shows the mass flow rate, mass total, volume flow rate, volume total, temperature, density, and drive gain. The display reports the abbreviated name of the process variable (for example, DENS for density), the current value of that process variable, and the associated unit of measure (for example, G/CM3).

If desired, you can configure the display to show other process variables, such as totalizers and inventories.

If Auto Scroll is enabled, the display cycles through the configured display variables, showing each display variable for a user-specified number of seconds.

Figure 9-1: Transmitter display features

- A. Status LED
- B. Display (LCD panel)
- C. Process variable
- D. Scroll optical switch
- E. Optical switch indicator: turns red when either Scroll or Select is activated
- F. Select optical switch
- G. Unit of measure for process variable
- H. Current value of process variable

9.2.2 View process variables using ProLink III

When you connect to a device, the process variables are displayed on the main screen of ProLink III.

Procedure

View the desired process variable(s).

Tip

ProLink III allows you to choose the process variables that appear on the main screen. You can also choose whether to view data in Analog Gauge view or digital view, and you can customize the gauge settings. For more information, see the ProLink III user manual.

9.3 View transmitter status using the status LED

The status LED shows the current alarm condition of the transmitter. The status LED is located on the face of the transmitter.

Observe the status LED.

- If your transmitter has a display, you can view the status LED with the transmitter housing cover in place.
- If your transmitter does not have a display, it does not have a status LED. This option is not available.

To interpret the status LED, see the following table.

Restriction

If LED Blinking is disabled, the status LED will flash only during calibration. It will not flash to indicate an unacknowledged alarm.

Table 9-1: Status LED states

LED behavior	Alarm condition	Description
Solid green	No alarm	Normal operation
Flashing green	No active alarm	Previously active alarm has not been acknowledged
Solid yellow	Active low-severity alarm	Alarm has been acknowledged
Flashing yellow	Active low-severity alarm	Alarm has not been acknowledged
Solid red	Active high-severity alarm	Alarm has been acknowledged
Flashing red	Active high-severity alarm	Alarm has not been acknowledged

9.4 View and acknowledge status alarms

The transmitter posts status alarms whenever a process variable exceeds its defined limits or the transmitter detects a fault condition. You can view active alarms, and you can acknowledge alarms.

9.4.1 View and acknowledge alarms using the display

You can view a list containing all alarms that are active, or inactive but unacknowledged. From this list, you can acknowledge individual alarms.

Note

Only Fault and Informational alarms are listed. The transmitter automatically filters out alarms with Status Alarm Severity set to Ignore.

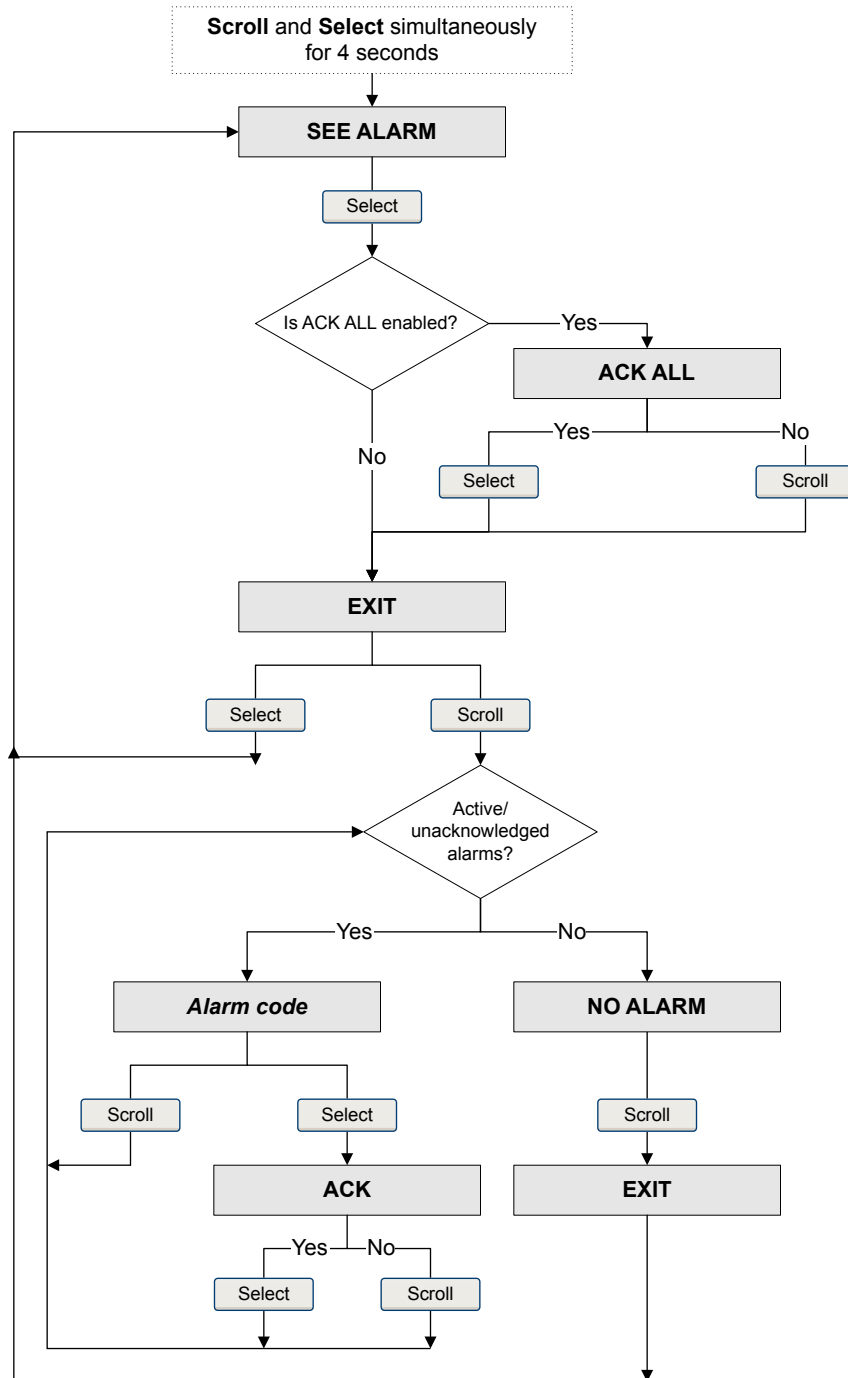
Prerequisites

Operator access to the alarm menu must be enabled (default setting). If operator access to the alarm menu is disabled, you must use another method to view or acknowledge status alarms.

Procedure

See [Figure 9-2](#).

Figure 9-2: Using the display to view and acknowledge the status alarms



Postrequisites

- To clear the following alarms, you must correct the problem, acknowledge the alarm, then power-cycle the transmitter: A001, A002, A010, A011, A012, A013, A018, A019, A022, A023, A024, A025, A028, A029, A031.
- For all other alarms:
 - If the alarm is inactive when it is acknowledged, it will be removed from the list.
 - If the alarm is active when it is acknowledged, it will be removed from the list when the alarm condition clears.

9.4.2 View and acknowledge alarms using ProLink II

You can view a list containing all alarms that are active, or inactive but unacknowledged. From this list, you can acknowledge individual alarms.

1. Choose ProLink > Alarm Log.
2. Choose the High Priority or Low Priority panel.

Note

The grouping of alarms into these two categories is hard-coded and is not affected by Status Alarm Severity.

All active or unacknowledged alarms are listed:

- Red indicator: Alarm is currently active.
- Green indicator: Alarm is inactive but unacknowledged.

Note

Only Fault and Informational alarms are listed. The transmitter automatically filters out alarms with Status Alarm Severity set to Ignore.

3. To acknowledge an alarm, check the Ack checkbox.

Postrequisites

- To clear the following alarms, you must correct the problem, acknowledge the alarm, then power-cycle the transmitter: A001, A002, A010, A011, A012, A013, A018, A019, A022, A023, A024, A025, A028, A029, A031.
- For all other alarms:
 - If the alarm is inactive when it is acknowledged, it will be removed from the list.
 - If the alarm is active when it is acknowledged, it will be removed from the list when the alarm condition clears.

9.4.3 View and acknowledge alerts using ProLink III

You can view a list containing all alerts that are active, or inactive and have been unacknowledged. From this list, you can acknowledge individual alerts or choose to acknowledge all alerts at once.

1. View alerts on the ProLink III main screen under Alerts.

All active or unacknowledged alarms are listed, and displayed according to the following categories:

Category	Description
Failed: Fix Now	A meter failure has occurred and must be addressed immediately.
Maintenance: Fix Soon	A condition has occurred that can be fixed at a later time.
Advisory: Informational	A condition has occurred, but requires no maintenance from you.

Notes

- All fault alerts are displayed in the Failed: Fix Now category.
 - All information alerts are displayed in either the Maintenance: Fix Soon category or the Advisory: Informational category. The category assignment is hard-coded.
 - The transmitter automatically filters out alerts with Alert Severity set to Ignore.
-
2. To acknowledge a single alert, check the Ack checkbox for that alert. To acknowledge all alerts at once, click Ack All.

Postrequisites

- To clear the following alarms, you must correct the problem, acknowledge the alarm, then power-cycle the transmitter: A001, A002, A010, A011, A012, A013, A018, A019, A022, A023, A024, A025, A028, A029, A031.
- For all other alarms:
 - If the alarm is inactive when it is acknowledged, it will be removed from the list.
 - If the alarm is active when it is acknowledged, it will be removed from the list when the alarm condition clears.

9.4.4 View alarms using the Field Communicator

You can view a list containing all alarms that are active, or inactive but unacknowledged.

- To view active or unacknowledged alarms, press Service Tools > Alerts.

All active alarms or unacknowledged alarms are listed.

Note

Only Fault and Informational alarms are listed. The transmitter automatically filters out alarms with Status Alarm Severity set to Ignore.

- To refresh the list of active or unacknowledged alarms, press Service Tools > Alerts > Refresh Alerts.

9.4.5 Alarm data in transmitter memory

The transmitter maintains three sets of data for every alarm that is posted.

For each alarm occurrence, the following three sets of data are maintained in transmitter memory:

- Alert List
- Alert Statistics
- Recent Alerts

Table 9-2: Alarm data in transmitter memory

Alarm data structure	Transmitter action if condition occurs	
	Contents	Clearing
Alert List	As determined by the alarm status bits, a list of: <ul style="list-style-type: none"> • All currently active alarms • All previously active alarms that have not been acknowledged 	Cleared and regenerated with every transmitter power cycle
Alert Statistics	One record for each alarm (by alarm number) that has occurred since the last master reset. Each record contains: <ul style="list-style-type: none"> • A count of the number of occurrences • Timestamps for the most recent posting and clearing 	Not cleared; maintained across transmitter power cycles
Recent Alerts	50 most recent alarm postings or alarm clearings	Not cleared; maintained across transmitter power cycles

9.5 Read totalizer and inventory values

Display	To read a totalizer or inventory value from the display, it must be configured as a display variable.
ProLink II	ProLink > Totalizer Control
ProLink III	View the desired variable on the main screen under Process Variables.
Field Communicator	Service Tools > Variables > Totalizer Control

Overview

Totalizers keep track of the total amount of mass or volume measured by the transmitter since the last totalizer reset. Inventories keep track of the total amount of mass or volume measured by the transmitter since the last inventory reset.

Tip

You can use the inventories to keep a running total of mass or volume across multiple totalizer resets.

9.6 Start and stop totalizers and inventories

Display	See Section 9.6.1 .
ProLink II	ProLink > Totalizer Control > Start ProLink > Totalizer Control > Stop
ProLink III	Device Tools > Totalizer Control > Totalizer and Inventories > Start All Totals Device Tools > Totalizer Control > Totalizer and Inventories > Stop All Totals
Field Communicator	Service Tools > Variables > Totalizer Control > All Totalizers > Start Totalizers Service Tools > Variables > Totalizer Control > All Totalizers > Stop Totalizers

Overview

When you start a totalizer, it tracks process measurement. In a typical application, its value increases with flow. When you stop a totalizer, it stops tracking process measurement and its value does not change with flow. Inventories are started and stopped automatically, when totalizers are started and stopped.

Important

Totalizers and inventories are started or stopped as a group. When you start any totalizer, all other totalizers and all inventories are started simultaneously. When you stop any totalizer, all other totalizers and all inventories are stopped simultaneously. You cannot start or stop inventories directly.

9.6.1 Start and stop totalizers and inventories using the display

Prerequisites

The Totalizer Start/Stop display function must be enabled.

At least one totalizer must be configured as a display variable.

Procedure

- To start all totalizers and inventories using the display:

1. Scroll until the word TOTAL appears in the lower left corner of the display.

Important

Because all totalizers are started or stopped together, it does not matter which total you use.

2. Select.
 3. Scroll until START appears beneath the current totalizer value.
 4. Select.
 5. Select again to confirm.
 6. Scroll to EXIT.
- To stop all totalizers and inventories using the display:
 1. Scroll until the word TOTAL appears in the lower left corner of the display.

Important

Because all totalizers are started or stopped together, it does not matter which total you use.

2. Select.
3. Scroll until STOP appears beneath the current totalizer value.
4. Select.
5. Select again to confirm.
6. Scroll to EXIT.

9.7 Reset totalizers

Display	See Section 9.7.1 .
ProLink II	ProLink > Totalizer Control > Reset Mass Total ProLink > Totalizer Control > Reset Volume Total ProLink > Totalizer Control > Reset Gas Volume Total ProLink > Totalizer Control > Reset
ProLink III	Device Tools > Totalizer Control > Totalizer and Inventories > Reset Mass Total Device Tools > Totalizer Control > Totalizer and Inventories > Reset Volume Total Device Tools > Totalizer Control > Totalizer and Inventories > Reset Gas Total Device Tools > Totalizer Control > Totalizer and Inventories > Reset All Totals
Field Communicator	Service Tools > Variables > Totalizer Control > Mass > Mass Total Service Tools > Variables > Totalizer Control > Gas Standard Volume > Volume Total Service Tools > Variables > Totalizer Control > Gas Standard Volume > GSV Total Service Tools > Variables > Totalizer Control > All Totalizers > Reset All Totals

Overview

When you reset a totalizer, the transmitter sets its value to 0. It does not matter whether the totalizer is started or stopped. If the totalizer is started, it continues to track process measurement.

Tip

When you reset a single totalizer, the values of other totalizers are not reset. Inventory values are not reset.

9.7.1 Reset totalizers using the display

Prerequisites

The Totalizer Reset display function must be enabled.

The totalizer that you want to reset must be configured as a display variable. For example:

- If you want to reset the mass totalizer, Mass Total must be configured as a display variable.
- If you want to reset the volume totalizer, Volume Total must be configured as a display variable.

Procedure

- To reset the mass totalizer:
 1. Scroll until the mass totalizer value appears.
 2. Select.

3. Scroll until RESET appears beneath the current totalizer value.
 4. Select.
 5. Select again to confirm.
 6. Scroll to EXIT.
 7. Select.
- To reset the volume totalizer:
 1. Scroll until the volume totalizer value appears.
 2. Select.
 3. Scroll until RESET appears beneath the current totalizer value.
 4. Select.
 5. Select again to confirm.
 6. Scroll to EXIT.
 7. Select.
 - To reset the gas standard volume totalizer:
 1. Scroll until the gas standard volume totalizer value appears.
 2. Select.
 3. Scroll until RESET appears beneath the current totalizer value.
 4. Select.
 5. Select again to confirm.
 6. Scroll to EXIT.
 7. Select.

9.8 Reset inventories

ProLink II	ProLink > Totalizer Control > Reset Inventories ProLink > Totalizer Control > Reset Mass Inventory ProLink > Totalizer Control > Reset Volume Inventory ProLink > Totalizer Control > Reset Gas Volume Inventory
ProLink III	Device Tools > Totalizer Control > Totalizer and Inventories > Reset Mass Inventory Device Tools > Totalizer Control > Totalizer and Inventories > Reset Volume Inventory Device Tools > Totalizer Control > Totalizer and Inventories > Reset Gas Inventory Device Tools > Totalizer Control > Totalizer and Inventories > Reset All Inventories

Overview

When you reset an inventory, the transmitter sets its value to 0. It does not matter whether the inventory is started or stopped. If the inventory is started, it continues to track process measurement.

Tip

When you reset a single inventory, the values of other inventories are not reset. Totalizer values are not reset.

Prerequisites

To use ProLink II or ProLink III to reset the inventories, the feature must be enabled.

- To enable inventory reset in ProLink II:
 1. Click View > Preferences.
 2. Check the Enable Inventory Totals Reset checkbox.
 3. Click Apply.
- To enable inventory reset in ProLink III:
 1. Choose Tools > Options.
 2. Select Reset Inventories from ProLink III.

10 Operate the transmitter with the Weights & Measures application

Topics covered in this chapter:

- *Operate the transmitter when the Weights & Measures application is installed*
- *Switch between secured and unsecured mode*
- *Clear Status Alarm A027: Security Breach*
- *Replacing the core processor in a Weights & Measures installation*

Information in this chapter is applicable only if your transmitter was ordered with the Weights & Measures application.

10.1 Operate the transmitter when the Weights & Measures application is installed

When the Weights & Measures application is installed, many of the basic functions of the transmitter are modified.

- To make a connection:
 - If the physical seal is not installed, you can use any supported connection type.
 - If the physical seal is installed, you cannot make a service port connection. You can use any other supported connection type.
- To read or obtain process data:
 - For an approved measurement, you must use an approved method.
 - If the measurement does not have to be approved, you can use any available method.

Important

The behavior of transmitter outputs and process variable values is modified by the Weights & Measures application. Ensure that you know the effects of this application on outputs and process variable values.

- To reset totalizers:
 - If the transmitter is unsecured, you can reset totalizers. If you reset one totalizer, all other totalizers are reset automatically.
 - If the transmitter is secured, you may or may not be able to reset totalizers, depending on configuration. If totalizer reset is enabled, you cannot reset totalizers unless the flow rate is 0. To reset totalizers from the display, you may need to enter the alarm menu password, whether or not you have enabled it. The default value for Alarm Menu Password is 1234.

- You cannot stop totalizers while the transmitter is secured.
- You cannot reset inventories while the transmitter is secured.

10.1.1 Approved methods to read or obtain process data

When the Weights & Measures application is installed, process data is approved for custody transfer use only if an approved method is used for reading or obtaining it.

Note

On the primary mA output, HART/Bell 202 communications may be used to poll for either temperature or pressure, in conjunction with process data reporting.

Table 10-1: NTEP-approved methods to read or obtain process data

Process data	mA output	Modbus/RS-485 or HART/RS-485	Transmitter display
Mass		✓	✓
Volume		✓	✓
Density	✓	✓	✓
Totalizer values		✓	✓
Inventory values		✓	✓

Table 10-2: OIML-approved methods to read or obtain process data

Process data	mA output	Modbus/RS-485 or HART/RS-485	Transmitter display
Mass		✓	✓
Volume		✓	✓
Density	✓	✓	✓
Totalizer values		✓	✓ ⁽¹⁾
Inventory values		✓	✓

10.1.2 Large totalizer values on the display (OIML applications only)

If Approval is set to OIML and totalizer values become large enough, the display handles large values in a special way. The value displayed may not reflect the actual value.

(1) Special handling is applied to large totalizer values.

The display is able to show a maximum of eight characters, including the decimal point. For all totalizer values configured as display variables, the position of the decimal point on the display is fixed to the configured precision of the display variable.

When the totalizer reaches the largest value that can be displayed in these circumstances:

- The digits roll over.
- The decimal point does not move.
- The number of digits on the display does not change.
- The internal totalizer is reset to 0.

For example, the value 99999.999 rolls over to 00000.000.

Tip

If you are not sure whether or not the totalizer value on the display has rolled over, check the value by using another method to read the current data.

Notes

- The mass and volume totalizers do not necessarily roll over at the same time.
 - This feature does not apply to inventories. The display presents large inventory values in the standard manner.
-

10.1.3 Effect of the Weights & Measures application on process measurement and outputs

When the Weights & Measures application is installed, process measurement and reporting is modified to prevent unauthorized use of the data. Specific changes are controlled by whether the transmitter is secured or unsecured.

Table 10-3: Transmitter outputs and process data when Approvals=NTEP

Function		Transmitter status	
		Unsecured	Secured
Outputs	mA output behavior	If reporting a flow variable, mA output reports zero flow. Otherwise, normal.	Normal
	Frequency output behavior	Inactive (produces no pulses), even under fault conditions	Normal
	Discrete output behavior	Normal	Normal
Process variables	All flow rates	Reported as zero	Reported normally
	Density	Reported normally	Reported normally
	Temperature	Reported normally	Reported normally
Totalizers	Values	Do not increment or decrement	Increment normally
Inventories	Values	Do not increment or decrement	Increment normally

Table 10-4: Transmitter outputs and process data when Approvals=OIML

Function		Transmitter status	
		Unsecured	Secured
Outputs	mA output behavior	Performs configured fault action	Normal
	Frequency output behavior	Performs configured fault action	Normal
	Discrete output behavior	Performs configured fault action	Normal
Process variables	All flow rates	Reported normally	Reported normally
	Density	Reported normally	Reported normally
	Temperature	Reported normally	Reported normally
Totalizers	Values	Do not increment or decrement	Increment normally
Inventories	Values	Do not increment or decrement	Increment normally

10.1.4 Effect of the Weights & Measures application on operation and maintenance functions

When the Weights & Measures application is installed, specific operations and maintenance activities may be disallowed. You can switch to unsecured mode, perform the required actions, then switch back to secured mode.

Table 10-5: Available actions when Approvals=NTEP

Function		Transmitter status	
		Unsecured	Secured
Connecting from ProLink II, ProLink III, the Field Communicator, or a host		All supported connection types are available.	Physical security prevents access to the service port terminals. Modbus/RS-485, HART/RS-485, and HART/Bell 202 connections can be used to read data from the transmitter, but software security prevents writing to the transmitter.
Configuration	Reading	Allowed	Allowed
	Changing	Allowed	Not allowed
Calibration	Zero	Allowed	Not allowed
	Density	Allowed	Not allowed
	Temperature	Allowed	Not allowed
Smart Meter Verification	Outputs set to Continue Measuring	Allowed	Allowed
	Outputs set to Fault	Allowed	Allowed

Table 10-5: Available actions when Approvals=NTEP (continued)

Function		Transmitter status	
		Unsecured	Secured
	Outputs set to Last Measured Value	Allowed	Not allowed
External pressure and temperature data	Retrieved by polling	Allowed	Allowed
	Written by Modbus or HART host	Allowed	Not allowed
Testing and trimming outputs	mA output loop test	Allowed	Not allowed
	mA output trim	Allowed	Not allowed
	Frequency output loop test	Not allowed	Not allowed
	Discrete output loop test	Allowed	Not allowed
Totalizers	Resetting	Allowed. If any single totalizer is reset, all other totalizers are reset automatically.	May or may not be allowed, depending on configuration. Can be performed only if flow rate is zero. If any single totalizer is reset, all other totalizers are reset automatically.
	Starting	Not allowed	N/A
	Stopping	N/A	Not allowed
Inventories	Resetting	Not allowed	Not allowed
Sensor simulation		Allowed	Not allowed

Table 10-6: Available actions when Approvals=OIML

Function		Transmitter status	
		Unsecured	Secured
Connecting from ProLink II, ProLink III, the Field Communicator, or a host		All supported connection types are available.	Physical security prevents access to the service port terminals. Modbus/RS-485, HART/RS-485, and HART/Bell 202 connections can be used to read data from the transmitter, but software security prevents writing to the transmitter.
Configuration	Reading	Allowed	Allowed
	Changing	Allowed	Not allowed
Calibration	Zero	Allowed	Not allowed
	Density	Allowed	Not allowed
	Temperature	Allowed	Not allowed

Table 10-6: Available actions when Approvals=OIML (continued)

Function		Transmitter status	
		Unsecured	Secured
Smart Meter Verification	Outputs set to Continue Measuring	Allowed	Allowed
	Outputs set to Fault	Allowed	Allowed
	Outputs set to Last Measured Value	Allowed	Not allowed
External pressure and temperature data	Retrieved by polling	Allowed	Allowed
	Written by Modbus or HART host	Allowed	Not allowed
Outputs	mA output loop test	Allowed	Not allowed
	mA output trim	Allowed	Not allowed
	Frequency output loop test	Allowed	Not allowed
	Discrete output loop test	Allowed	Not allowed
Process variables	All flow rates	Reported normally	Reported normally
	Density	Reported normally	Reported normally
	Temperature	Reported normally	Reported normally
Totalizers	Resetting	Allowed. If any single totalizer is reset, all other totalizers are reset automatically.	May or may not be allowed, depending on configuration. Can be performed only if flow rate is zero. If any single totalizer is reset, all other totalizers are reset automatically.
	Starting	Not allowed	N/A
	Stopping	N/A	Not allowed
Inventories	Resetting	Allowed	Not allowed
Sensor simulation		Allowed	Not allowed

10.2 Switch between secured and unsecured mode

You must switch to unsecured mode to change the transmitter configuration or perform many administrative tasks. You must switch back to secured mode in order to meet Weights & Measures requirements for process measurement.

You must use one of the following tools to switch modes:

- ProLink II
- ProLink III
- The Custody Transfer “switching” utility. The switching utility is free, and is available from the Micro Motion web site: www.micromotion.com/softwaredownloads.

The controls are not accessible in any other way.

10.2.1 Switch between secured and unsecured mode using ProLink II

Prerequisites

Before switching to unsecured mode, ensure that you will be able to switch back to secured mode. Because switching to unsecured mode requires breaking the physical seal, switching back to secured mode may require a site visit from a certified Weights & Measures inspector and reinstallation of the physical seal.

Ensure that the wiring is in place for a service port connection. You may need to break the seal and remove the clamp.

Procedure

- To switch from secured mode to unsecured mode:
 1. Make a service port connection to your transmitter.
 2. Choose Plug-ins > Enable/Disable Custody Transfer.
 3. Click Disable Custody Transfer.
- To switch from unsecured mode to secured mode:
 1. Make a service port connection to your transmitter.
 2. Choose Plug-ins > Enable/Disable Custody Transfer
 3. Click Enable Custody Transfer.

10.2.2 Switch between secured and unsecured mode using ProLink III

Prerequisites

Before switching to unsecured mode, ensure that you will be able to switch back to secured mode. Because switching to unsecured mode requires breaking the physical seal, switching back to secured mode may require a site visit from a certified Weights & Measures inspector and reinstallation of the physical seal.

Ensure that the wiring is in place for a service port connection. You may need to break the seal and remove the clamp.

Procedure

- To switch from secured mode to unsecured mode:
 1. Make a service port connection to your transmitter.
 2. Choose Device Tools > Configuration > Weights & Measures.
 3. Set Software Security to Disabled.
- To switch from unsecured mode to secured mode:

1. Make a service port connection to your transmitter.
2. Choose Device Tools > Configuration > Weights & Measures.
3. Set Software Security to Enabled.

10.2.3 Switch between secured and unsecured mode using the switching utility

Prerequisites

The switching utility must be installed on your PC. The switching utility is available from the Micro Motion web site: www.micromotion.com/softwaredownloads.

Before switching to unsecured mode, ensure that you will be able to switch back to secured mode. Because switching to unsecured mode requires breaking the physical seal, switching back to secured mode may require a site visit from a certified Weights & Measures inspector and reinstallation of the physical seal.

Ensure that the wiring is in place for a service port connection. You may need to break the seal and remove the clamp.

Procedure

- To switch from secured mode to unsecured mode:
 1. Run the switching utility.
 2. Select the COM port to use for the connection.
 3. Click Disable Custody Transfer.
- To switch from unsecured mode to secured mode:
 1. Run the switching utility.
 2. Select the COM port to use for the connection.
 3. Click Enable Custody Transfer.

10.3 Clear Status Alarm A027: Security Breach

Status Alarm A027: Security Breach is posted if the transmitter is switched to unsecured mode or if the transmitter detects that the core processor ID has changed.

1. If the transmitter is in secured mode, switch to unsecured mode.
2. Take any required actions related to the cause of the security breach.
3. Switch to secured mode.

10.4 Replacing the core processor in a Weights & Measures installation

In a Weights & Measures installation, replacing the core processor requires re-sealing the transmitter.

When the transmitter is first secured, the core processor's unique ID is registered with the transmitter. If you replace the core processor with another core processor, the transmitter will post Status Alarm A026: Sensor/Xmtr Communication Error. To clear this alarm, you must switch the transmitter to unsecured mode and resecure it. This requires breaking the physical seal and reinstalling it when the entire process is complete.

Other procedures may be required. Refer to the Weights & Measurements documentation for your installation.

Important

In most cases, the physical seal must be installed by a certified Weights & Measures inspector.

11 Measurement support

Topics covered in this chapter:

- *Options for measurement support*
- *Use Smart Meter Verification*
- *Zero the flowmeter*
- *Validate the meter*
- *Perform a (standard) D1 and D2 density calibration*
- *Perform a D3 and D4 density calibration (T-Series sensors only)*
- *Perform temperature calibration*

11.1 Options for measurement support

Micro Motion provides several measurement support procedures to help you evaluate and maintain your flowmeter's accuracy.

The following methods are available:

- Smart Meter Verification evaluates the structural integrity of the sensor tubes by comparing current tube stiffness to the stiffness measured at the factory. Stiffness is defined as the load per unit deflection, or force divided by displacement. Because a change in structural integrity changes the sensor's response to mass and density, this value can be used as an indicator of measurement performance.
- Meter validation compares flowmeter measurements reported by the transmitter to an external measurement standard. Meter validation requires one data point.
- Calibration establishes the relationship between a process variable and the signal produced at the sensor. You can calibrate the flowmeter for zero, density, and temperature. Density and temperature calibration require two data points (low and high) and an external measurement for each.

Tips

- Perform Smart Meter Verification at regular intervals to get the best data on your meter's performance.
 - To prove the meter against a regulatory standard, or to correct measurement error, use meter validation and meter factors.
 - Before performing a field calibration, contact Micro Motion to see if there is an alternative. In many cases, field calibrations have a negative effect on measurement accuracy.
-

11.2 Use Smart Meter Verification

You can run a Smart Meter Verification test, view and interpret the results, and set up automatic execution.

11.2.1 Smart Meter Verification requirements

To use Smart Meter Verification, the transmitter must be paired with an enhanced core processor, and the Smart Meter Verification option must be ordered for the transmitter.

See [Table 11-1](#) for the minimum version of the transmitter, enhanced core processor, and communication tool needed to support Smart Meter Verification. (If you are going to perform Smart Meter Verification using the display, only the transmitter and enhanced core processor versions apply.)

Table 11-1: Minimum version to support Smart Meter Verification

Item	Minimum version
Transmitter	6.0
Enhanced core processor	3.6
ProLink II	2.9
ProLink III	1.0
Field Communicator	HART device description: device rev 6, DD rev 2

If your devices or tools do not meet the minimum version requirements for Smart Meter Verification, you still may have access to an older version of meter verification if the option was ordered for your transmitter. See [Table 11-2](#) for a description of the major differences between the older meter verification and the newer Smart Meter Verification.

Table 11-2: Major differences between meter verification and Smart Meter Verification

Feature	Meter verification (older)	Smart Meter Verification (newer)
Measurement interruption	Suspended during the test (3 minutes)	No interruption necessary
Result storage	No results stored in the transmitter	Last 20 results stored in the transmitter
Results reporting	Pass/fail/abort	Pass/fail/abort, abort code, comparison tables and graphs for stored test results ⁽¹⁾
Test start methods	Manual only	Manual, scheduled, event-based

11.2.2 Smart Meter Verification test preparation

Although it is not necessary to match factory conditions or change the transmitter's configuration during a Smart Meter Verification test, the test will run more smoothly when conditions are stable.

(1) Detailed test analyses such as comparison graphs are not available on the local display.

Smart Meter Verification has an output mode called Continuous Measurement that allows the transmitter to keep measuring while the test is in progress. If you choose to run the test in Last Measured Value or Fault modes instead, the transmitter outputs will be held constant for the two minute duration of the test. If control loops depend on transmitter outputs, take appropriate action.

Avoid process instability during the test. If conditions are too unstable, the Smart Meter Verification test will abort. To maximize process stability:

- Maintain a constant fluid pressure and temperature.
- Avoid changes to fluid composition, e.g., two-phase flow or settling.
- Maintain a constant flow rate.

Tips

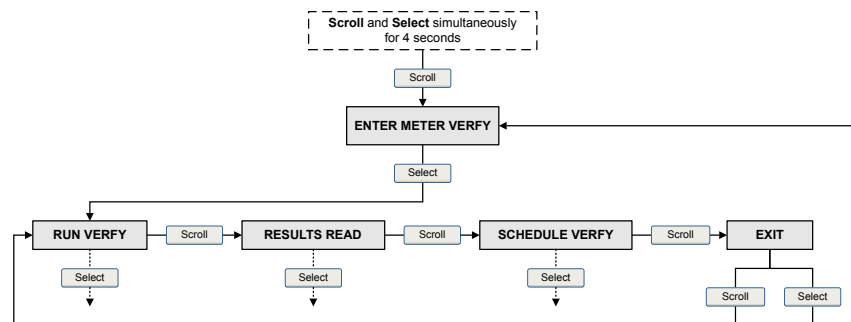
- The Smart Meter Verification test runs best when flow is stopped through the sensor.
- Smart Meter Verification is not affected by any configured transmitter parameters for flow, density, or temperature.

11.2.3 Run Smart Meter Verification

Run a Smart Meter Verification test using the display

1. Navigate to the Smart Meter Verification menu.

Figure 11-1: Smart Meter Verification – Top-level menu



2. Choose Run Verify.
3. Choose Outputs and select the desired output behavior.

Option	Description
Continue Measr	During the test, all outputs will continue to report their assigned process variable. The test will run for approximately 90 seconds.
Fault	During the test, all outputs will report the last measured value of their assigned process variable. The test will run for approximately 140 seconds.

Option	Description
Last Value	During the test, all outputs will go to their configured fault action. The test will run for approximately 140 seconds.

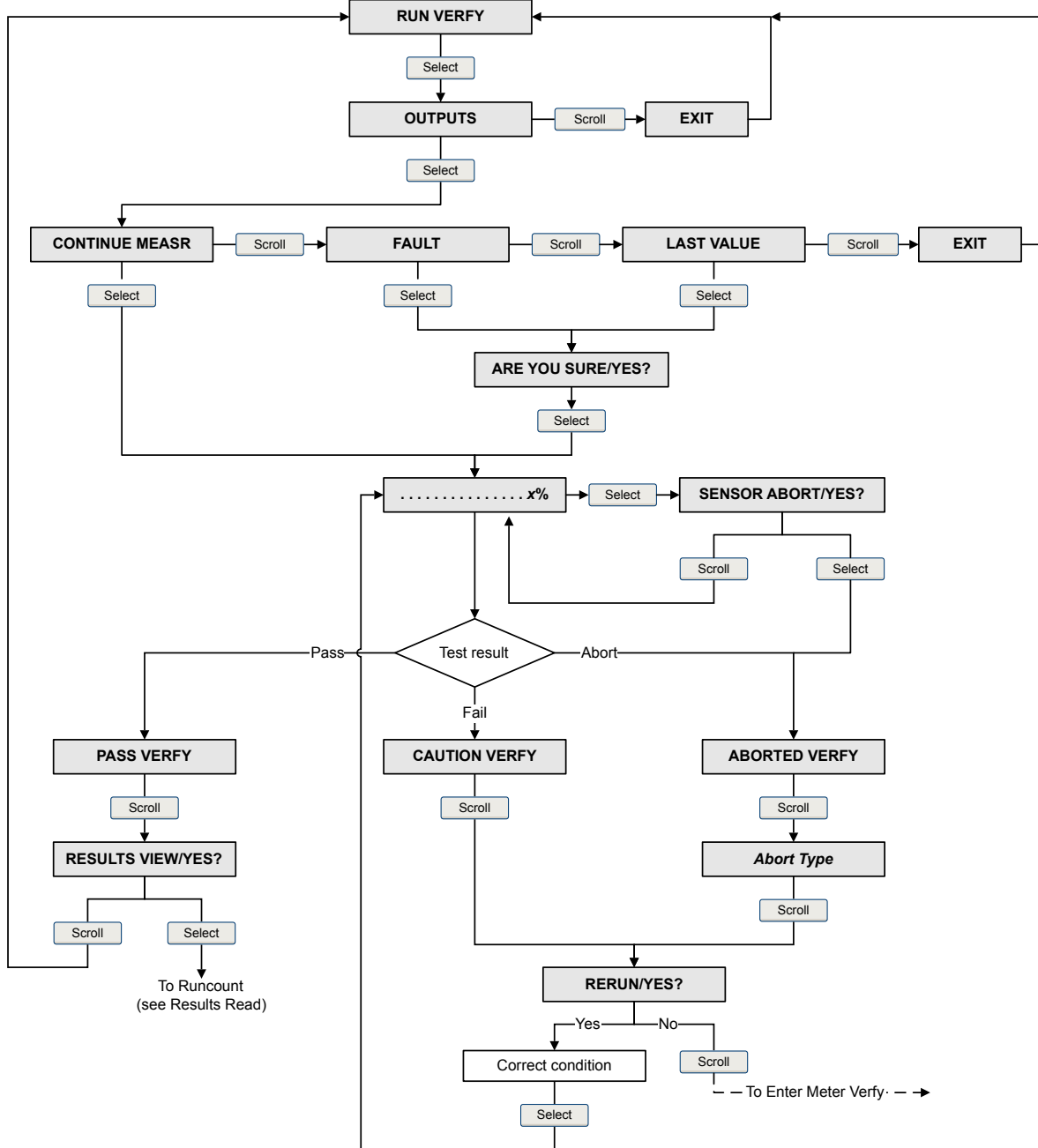
While the test is in progress, dots traverse the display and test progress is shown.

Postrequisites

View the test results and take any appropriate actions.

Smart Meter Verification flowchart: Running a test using the display

Figure 11-2: Running a Smart Meter Verification test using the display



Run a Smart Meter Verification test using ProLink II

1. Choose Tools > Meter Verification > Run Meter Verification.

You may need to wait a few seconds while ProLink II synchronizes its database with the transmitter data.

2. Review the information presented on the screen, and click Next.
3. Enter any desired information on the Test Definition screen, and click Next.

All information on this screen is optional.

4. Choose the desired output behavior.

Option	Description
Outputs Continue Measuring	During the test, all outputs will continue to report their assigned process variable. The test will run for approximately 90 seconds.
Outputs Held at Last Value	During the test, all outputs will report the last measured value of their assigned process variable. The test will run for approximately 140 seconds.
Outputs Held at Fault	During the test, all outputs will go to their configured fault action. The test will run for approximately 140 seconds.

5. Press Start Meter Verification.

Test progress is displayed on the screen.

Postrequisites

View the test results and take any appropriate actions.

Run a Smart Meter Verification test using ProLink III

1. Choose Device Tools > Diagnostics > Meter Verification > Run Test.

You may need to wait a few seconds while ProLink II synchronizes its database with the transmitter data.

2. Enter any desired information on the Test Definition screen, and click Next.

All information on this screen is optional.

3. Choose the desired output behavior.

Option	Description
Continue Measuring	During the test, all outputs will continue to report their assigned process variable. The test will run for approximately 90 seconds.
Held at Last Value	During the test, all outputs will report the last measured value of their assigned process variable. The test will run for approximately 140 seconds.
Held at Fault	During the test, all outputs will go to their configured fault action. The test will run for approximately 140 seconds.

4. Press Start.

Test progress is displayed on the screen.

Postrequisites

View the test results and take any appropriate actions.

Run a Smart Meter Verification test using the Field Communicator

1. Navigate to the Smart Meter Verification menu:
 - Overview > Shortcuts > Meter Verification
 - Service Tools > Maintenance > Routine Maintenance > Meter Verification
2. Choose Manual Verification.
3. Choose Start.
4. Set output behavior as desired, and press OK if prompted.

Option	Description
Continue Measuring	During the test, all outputs will continue to report their assigned process variable. The test will run for approximately 90 seconds.
Outputs Held at Last Value	During the test, all outputs will report the last measured value of their assigned process variable. The test will run for approximately 140 seconds.
Outputs Held at Fault	During the test, all outputs will go to their configured fault action. The test will run for approximately 140 seconds.

Test progress is displayed on the screen.

Postrequisites

View the test results and take any appropriate actions.

11.2.4 View test data

You can view the results of the current test. You can also view results from previous tests.

The transmitter stores the following information about the last twenty Smart Meter Verification tests:

- Powered-on hours at the time of the test.
- Test result (Pass, Fail, Abort).
- Stiffness of the left and right pickoffs, shown as percentage variation from the factory value. If the test aborted, 0 is stored for these values.
- Abort code, if applicable.

In addition, ProLink II and ProLink III provide a detailed test reporting and analysis framework. This information is stored on the PC where ProLink II or ProLink III is installed. It includes:

- Timestamp from the PC clock

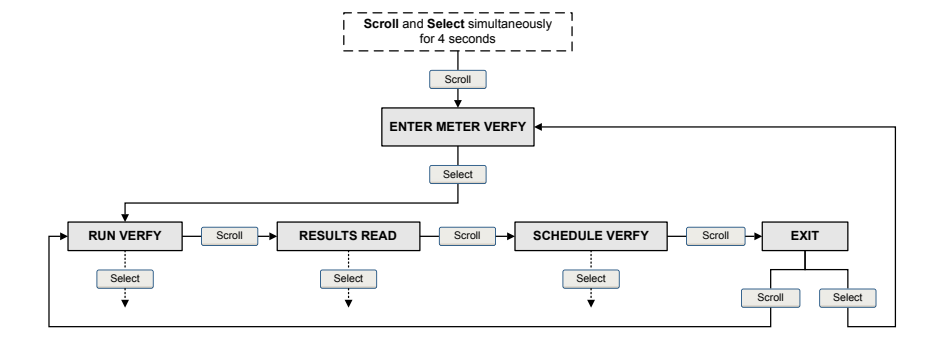
- Current flowmeter identification data
- Current flow and density configuration parameters
- Current zero values
- Current process values for mass flow rate, volume flow rate, density, temperature, and external pressure
- Customer and test descriptions (if entered by the user)

If you use ProLink II or ProLink III to run a test, a test result chart and a test report are displayed at the completion of the test. On-screen directions are provided to manipulate the test data or export the data to a CSV file for offline analysis.

View test result data using the display

1. If you have just run a test, results are displayed automatically at the end of the test.
2. If you want to view results from previous tests:
 - a. Navigate to the Smart Meter Verification menu.

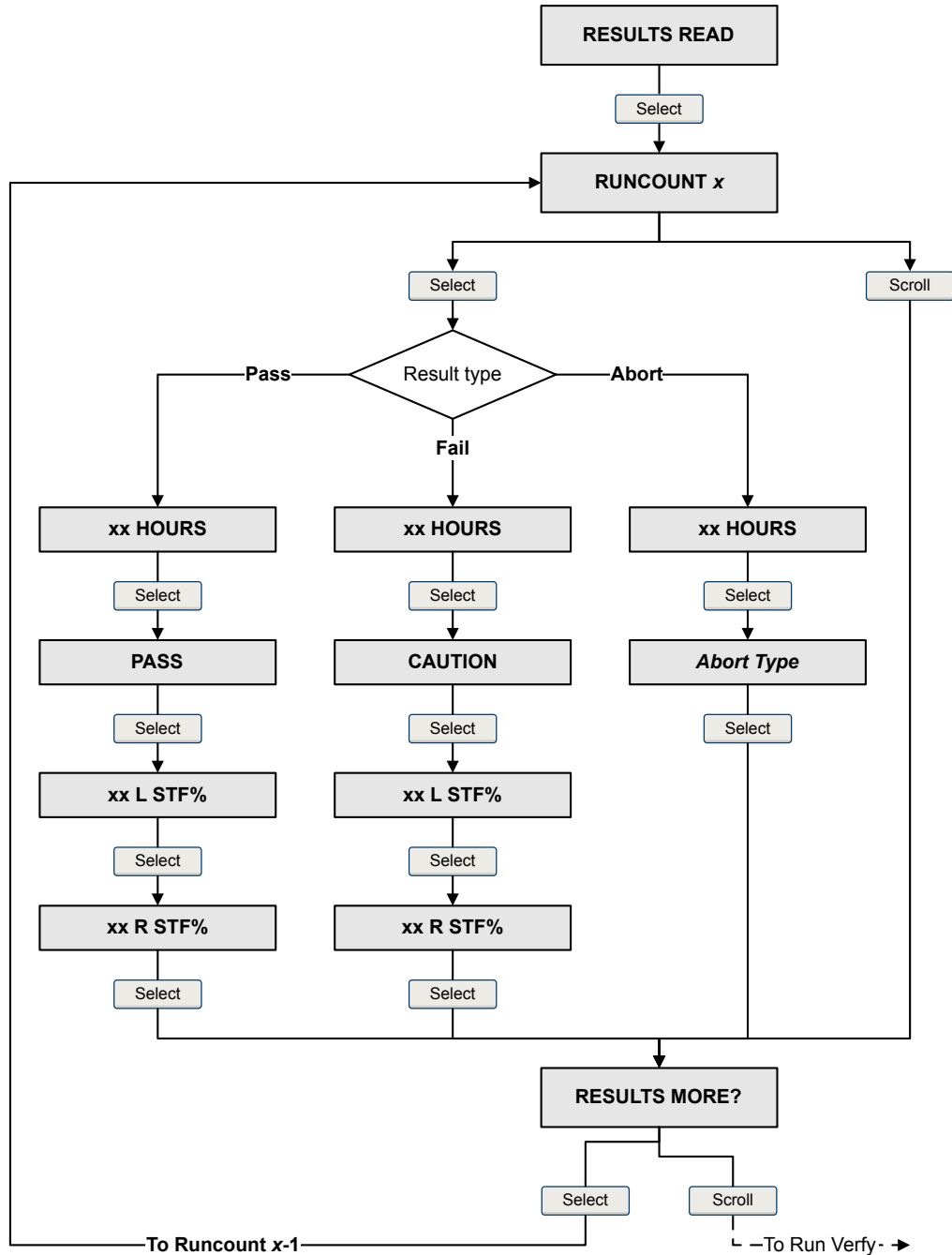
Figure 11-3: Smart Meter Verification – Top-level menu



- b. Scroll to Results Read and press Select.
The runcount of the most recent test is displayed.
- c. To view data for this test, press Select, then press Scroll to scroll through test data.
- d. To select a different test, press Scroll, then press Select when the transmitter displays Results More?. When the desired test appears, as identified by runcount, press Select.

Smart Meter Verification flowchart: Viewing test results using the display

Figure 11-4: Viewing Smart Meter Verification test results using the display



View test result data using ProLink II

1. Choose Tools > Meter Verification > Run Meter Verification and click View Previous Test Results and Print Report.

The chart shows test results for all tests stored in the ProLink II database.

2. (Optional) Click Next to view and print a test report.
3. (Optional) Click Export Data to CSV File to save the data to a file on your PC.

View test result data using ProLink III

1. Choose Device Tools > Diagnostics > Meter Verification and click Previous Test Results.

The chart shows test results for all tests stored in the ProLink III database.

2. (Optional) Click Next to view and print a test report.
3. (Optional) Click Export Data to CSV File to save the data to a file on your PC.

View test result data using the Field Communicator

1. Navigate to the Smart Meter Verification menu:
 - Overview > Shortcuts > Meter Verification
 - Service Tools > Maintenance > Routine Maintenance > Meter Verification
2. (Optional) If the Field Communicator database is out of date, choose Upload Results Data from Device.
3. To view data from the most recent test, choose Most Recent Test Results.
4. To view data for all tests in the Field Communicator database:
 - a. Press Show Results Table.

Data from the most recent test is displayed.
 - b. Press OK to scroll through data from previous tests.
 - c. To exit the results table, press Abort.

Smart Meter Verification results interpretation

When the meter verification test is completed, the result is reported as Pass, Fail, or Abort. (Some tools report the Fail result as Caution instead.)

- Pass** The test result is within the specification uncertainty limit. In other words, the stiffness of the left and right pickoffs match the factory values plus or minus the specification uncertain limit. If transmitter zero and configuration match factory values, the sensor will meet factory specifications for flow and density measurement. It is expected that meters will pass meter verification every time the test is run.

Fail The test result is not within the specification uncertainty limit. Micro Motion recommends that you immediately repeat the meter verification test. If during the failed test you had set outputs to Continue Measurement, set outputs to Fault or Last Measured Value instead.

- If the meter passes the second test, the first result can be ignored.
- If the meter fails the second test, the flow tubes may be damaged. Use your process knowledge to determine the possibilities for damage and the appropriate actions for each. These actions might include removing the meter from service and physically inspecting the tubes. At minimum, you should perform a flow validation and a density calibration.

Abort A problem occurred with the meter verification test (e.g., process instability) or you stopped the test manually. See [Table 11-3](#) for a list of abort codes, a description of each code, and possible actions you can take in response.

Table 11-3: Smart Meter Verification abort codes

Code	Description	Recommended actions
1	User-initiated abort	None required. Wait 15 seconds before starting another test.
3	Frequency drift	Ensure that temperature, flow, and density are stable, and rerun the test.
5	High drive gain	Ensure that flow is stable, minimize entrained gas, and rerun the test.
8	Unstable flow	Check factors that could cause process instability, then rerun the test. To maximize process stability: <ul style="list-style-type: none"> • Maintain a constant fluid pressure and temperature. • Avoid changes to fluid composition, e.g., two-phase flow or settling. • Maintain a constant flow rate.
13	No factory reference data for meter verification test performed on air	Contact Micro Motion.
14	No factory reference data for meter verification test performed on water	Contact Micro Motion.
15	No configuration data for meter verification	Contact Micro Motion.
Other	General abort	Repeat the test. If the test aborts again, contact Micro Motion.

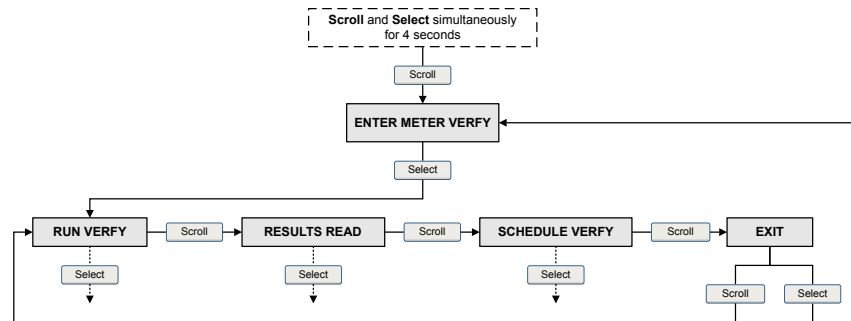
11.2.5 Schedule automatic execution of the Smart Meter Verification test

You can set up and run a single test at a user-defined future time. You can also set up and run tests on a regular schedule.

Manage scheduled test execution using the display

1. Navigate to the Smart Meter Verification menu.

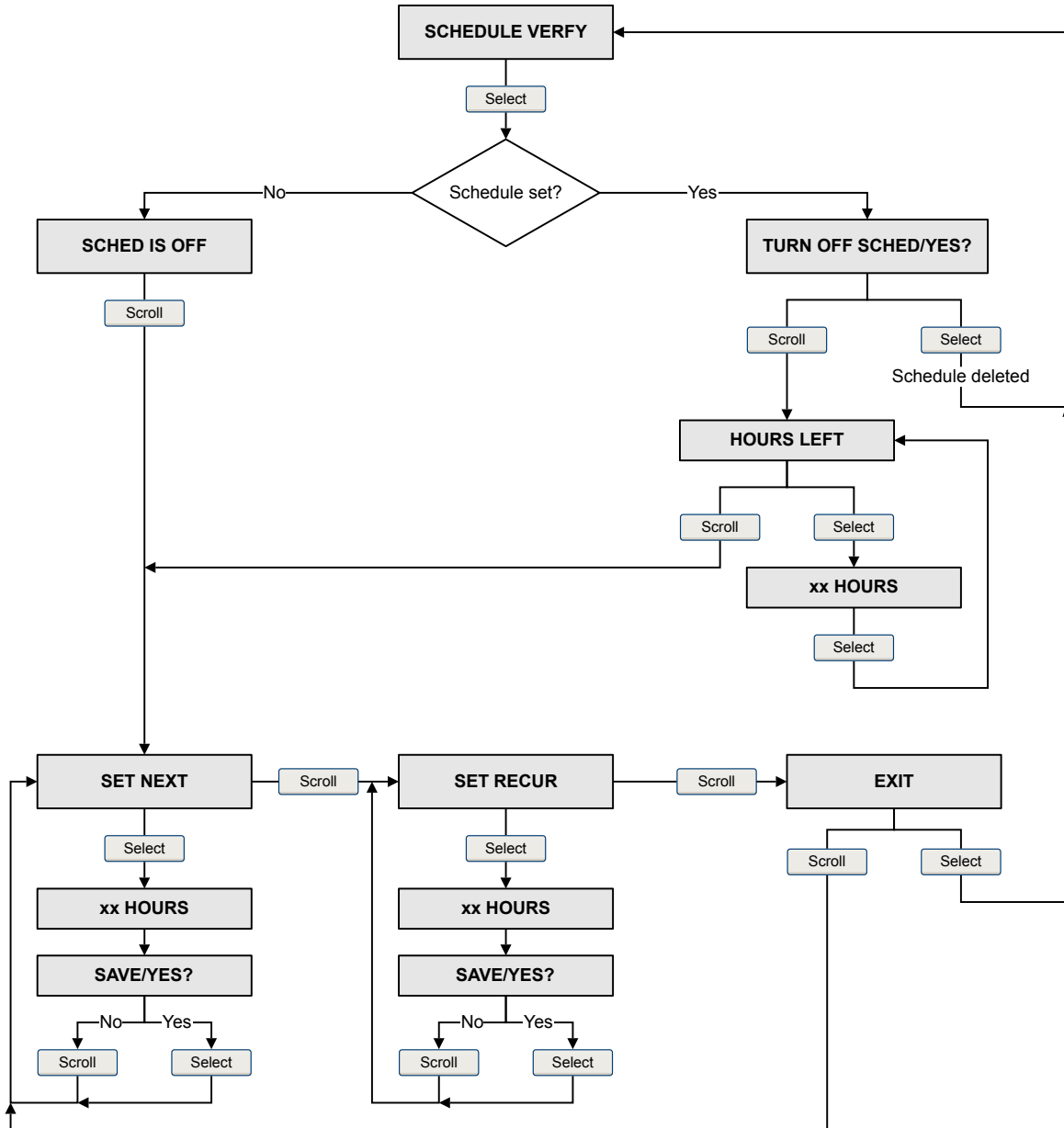
Figure 11-5: Smart Meter Verification – Top-level menu



2. Scroll to Schedule Verify and press Select.
3. To schedule a single test or the first test in recurring execution:
 - a. Scroll to Set Next and press Select.
 - b. Enter the number of hours that the transmitter will wait before beginning the test.
4. To schedule recurring execution:
 - a. Scroll to Set Recur and press Select.
 - b. Enter the number of hours that will elapse between tests.
5. To disable scheduled execution:
 - To disable execution of a single scheduled test, set Set Next to 0.
 - To disable recurring execution, set Set Recur to 0.
 - To disable all scheduled execution, choose Turn Off Sched when you enter the Smart Meter Verification menu.

Smart Meter Verification flowchart: Scheduling test execution using the display

Figure 11-6: Scheduling Smart Meter Verification test execution using the display



Manage scheduled test execution using ProLink II

1. Choose Tools > Meter Verification > Schedule Meter Verification.
2. To schedule a single test or the first test in recurring execution, specify a value for Hours Until Next Run.
3. To schedule recurring execution, specify a value for Hours Between Recurring Runs.

4. To disable scheduled execution:
 - To disable execution of a single scheduled test, set Hours Until Next Run to 0.
 - To disable recurring execution, set Hours Between Recurring Runs to 0.
 - To disable all scheduled execution, click Turn Off Schedule.

Manage scheduled test execution using ProLink III

1. Choose Device Tools > Diagnostics > Meter Verification > Schedule Meter Verification.
2. To schedule a single test or the first test in recurring execution, specify a value for Hours Until Next Run.
3. To schedule recurring execution, specify a value for Hours Between Recurring Runs.
4. To disable scheduled execution:
 - To disable execution of a single scheduled test, set Hours Until Next Run to 0.
 - To disable recurring execution, set Hours Between Recurring Runs to 0.
 - To disable all scheduled execution, click Disable Scheduled Execution.

Manage scheduled test execution using the Field Communicator

1. Navigate to the Smart Meter Verification menu:
 - Overview > Shortcuts > Meter Verification
 - Service Tools > Maintenance > Routine Maintenance > Meter Verification
2. Choose Automatic Verification.
3. To schedule a single test or the first test in recurring execution, specify a value for Hrs Until Next Run.
4. To schedule recurring execution, specify a value for Set Recurring Hours.
5. To disable scheduled execution:
 - To disable execution of a single scheduled test, set Hrs Until Next Run to 0.
 - To disable recurring execution, set Set Recurring Hours to 0.
 - To disable all scheduled execution, choose Turn Off Schedule.

11.3 Zero the flowmeter

Zeroing the flowmeter establishes a baseline for process measurement by analyzing the sensor's output when there is no flow through the sensor tubes.

Important

In most cases, the factory zero is more accurate than the field zero. Do not zero the flowmeter unless one of the following is true:

- The zero is required by site procedures.
 - The stored zero value fails the Zero Verification procedure.
-

Prerequisites

Before performing a field zero, execute the Zero Verification procedure to see whether or not a field zero can improve measurement accuracy. See [Section 2.6](#).

Important

Do not verify the zero or zero the flowmeter if a high-severity alarm is active. Correct the problem, then verify the zero or zero the flowmeter. You may verify the zero or zero the flowmeter if a low-severity alarm is active.

11.3.1 Zero the flowmeter using the display

Zeroing the flowmeter establishes a baseline for process measurement by analyzing the sensor's output when there is no flow through the sensor tubes.

Restriction

You cannot change the Zero Time setting from the display. The current setting of Zero Time will be applied to the zero procedure. The default value is 20 seconds. If you need to change Zero Time, you must make a connection to the transmitter from a communications tool such as ProLink II.

Prerequisites

Assign the following as display variables:

- Live Zero or Field Verification Zero
- Drive Gain
- Temperature
- Density

See [Section 5.1.2](#) for assistance.

Procedure

1. Prepare the flowmeter:
 - a. Allow the flowmeter to warm up for at least 20 minutes after applying power.
 - b. Run the process fluid through the sensor until the sensor temperature reaches the normal process operating temperature.
 - c. Stop flow through the sensor by shutting the downstream valve, and then the upstream valve if available.
 - d. Verify that the sensor is blocked in, that flow has stopped, and that the sensor is completely full of process fluid.
 - e. Observe the drive gain, temperature, and density readings. If they are stable, check the Live Zero or Field Verification Zero value. If the average value is close to 0, you should not need to zero the flowmeter.

2. Navigate to OFFLINE MAINT > ZERO > CAL ZERO and select CAL/YES?.
Dots traverse the display while flowmeter zero is in progress.
3. Read the zero result on the display.
The display reports CAL PASS if the zero was successful, or CAL FAIL if it was not.

Postrequisites

Restore normal flow through the sensor by opening the valves.

Need help? If the zero fails:

- Ensure that there is no flow through the sensor, then retry.
- Remove or reduce sources of electromechanical noise, then retry.
- Set Zero Time to a lower value, then retry.
- If the zero continues to fail, contact Micro Motion.
- If you want to return the flowmeter to operation using a previous zero value:
 - To restore the zero value set at the factory: OFFLINE MAINT > ZERO > RESTORE ZERO > RESTORE/YES? . This function requires the enhanced core processor.

Restriction

Restore the factory zero only if your flowmeter was purchased as a unit, it was zeroed at the factory, and you are using the original components.

11.3.2 Zero the flowmeter using ProLink II

Zeroing the flowmeter establishes a baseline for process measurement by analyzing the sensor's output when there is no flow through the sensor tubes.

Prerequisites

ProLink II must be running and must be connected to the transmitter.

Procedure

1. Prepare the flowmeter:
 - a. Allow the flowmeter to warm up for at least 20 minutes after applying power.
 - b. Run the process fluid through the sensor until the sensor temperature reaches the normal process operating temperature.
 - c. Stop flow through the sensor by shutting the downstream valve, and then the upstream valve if available.
 - d. Verify that the sensor is blocked in, that flow has stopped, and that the sensor is completely full of process fluid.
 - e. Observe the drive gain, temperature, and density readings. If they are stable, check the Live Zero or Field Verification Zero value. If the average value is close to 0, you should not need to zero the flowmeter.
2. Choose ProLink > Calibration > Zero Verification and Calibration.

3. Click Calibrate Zero.
4. Modify Zero Time, if desired.

Zero Time controls the amount of time the transmitter takes to determine its zero-flow reference point. The default Zero Time is 20 seconds. For most applications, the default Zero Time is appropriate.

5. Click Perform Auto Zero.

The Calibration in Progress light will turn red during the zero procedure. At the end of the procedure:

- If the zero procedure was successful, the Calibration in Progress light returns to green and a new zero value is displayed.
- If the zero procedure failed, the Calibration Failure light turns red.

Postrequisites

Restore normal flow through the sensor by opening the valves.

Need help? If the zero fails:

- Ensure that there is no flow through the sensor, then retry.
- Remove or reduce sources of electromechanical noise, then retry.
- Set Zero Time to a lower value, then retry.
- If the zero continues to fail, contact Micro Motion.
- If you want to return the flowmeter to operation using a previous zero value:
 - To restore the zero value set at the factory: ProLink > Zero Verification and Calibration > Calibrate Zero > Restore Factory Zero . This function requires the enhanced core processor.
 - To restore the most recent valid value from transmitter memory: ProLink > Zero Verification and Calibration > Calibrate Zero > Restore Prior Zero . Restore Prior Zero is available only while the Flow Calibration window is open. If you close the Flow Calibration window, you will no longer be able to restore the prior zero.

Restriction

Restore the factory zero only if your flowmeter was purchased as a unit, it was zeroed at the factory, and you are using the original components.

11.3.3 Zero the flowmeter using ProLink III

Zeroing the flowmeter establishes a baseline for process measurement by analyzing the sensor's output when there is no flow through the sensor tubes.

Prerequisites

ProLink III must be running and must be connected to the transmitter.

Procedure

1. Prepare the flowmeter:

- a. Allow the flowmeter to warm up for at least 20 minutes after applying power.
 - b. Run the process fluid through the sensor until the sensor temperature reaches the normal process operating temperature.
 - c. Stop flow through the sensor by shutting the downstream valve, and then the upstream valve if available.
 - d. Verify that the sensor is blocked in, that flow has stopped, and that the sensor is completely full of process fluid.
 - e. Observe the drive gain, temperature, and density readings. If they are stable, check the Live Zero or Field Verification Zero value. If the average value is close to 0, you should not need to zero the flowmeter.
2. Choose Device Tools > Calibration > Zero Verification and Calibration.
 3. Click Calibrate Zero.
 4. Modify Zero Time, if desired.

Zero Time controls the amount of time the transmitter takes to determine its zero-flow reference point. The default Zero Time is 20 seconds. For most applications, the default Zero Time is appropriate.

5. Click Calibrate Zero.

The Calibration in Progress message is displayed. When the calibration is complete:

- If the zero procedure was successful, a Calibration Success message and a new zero value are displayed.
- If the zero procedure failed, a Calibration Failed message is displayed.

Postrequisites

Restore normal flow through the sensor by opening the valves.

Need help? If the zero fails:

- Ensure that there is no flow through the sensor, then retry.
- Remove or reduce sources of electromechanical noise, then retry.
- Set Zero Time to a lower value, then retry.
- If the zero continues to fail, contact Micro Motion.
- If you want to return the flowmeter to operation using a previous zero value:
 - To restore the zero value set at the factory: Device Tools > Zero Verification and Calibration > Calibrate Zero > Restore Factory Zero . This function requires the enhanced core processor.
 - To restore the most recent valid value from transmitter memory: Device Tools > Zero Verification and Calibration > Calibrate Zero > Restore Prior Zero . Restore Prior Zero is available only while the Flow Calibration window is open. If you close the Flow Calibration window, you will no longer be able to restore the prior zero.

Restriction

Restore the factory zero only if your flowmeter was purchased as a unit, it was zeroed at the factory, and you are using the original components.

11.3.4 Zero the flowmeter using the Field Communicator

Zeroing the flowmeter establishes a baseline for process measurement by analyzing the sensor's output when there is no flow through the sensor tubes.

1. Prepare the flowmeter:
 - a. Allow the flowmeter to warm up for at least 20 minutes after applying power.
 - b. Run the process fluid through the sensor until the sensor temperature reaches the normal process operating temperature.
 - c. Stop flow through the sensor by shutting the downstream valve, and then the upstream valve if available.
 - d. Verify that the sensor is blocked in, that flow has stopped, and that the sensor is completely full of process fluid.
 - e. Observe the drive gain, temperature, and density readings. If they are stable, check the Live Zero or Field Verification Zero value. If the average value is close to 0, you should not need to zero the flowmeter.
2. Press Service Tools > Maintenance > Zero Calibration > Perform Auto Zero.
3. Modify Zero Time, if desired.

Zero Time controls the amount of time the transmitter takes to determine its zero-flow reference point. The default Zero Time is 20 seconds. For most applications, the default Zero Time is appropriate.

4. Press OK to start the zero, and wait while the zero calibration is performed.
5. When the zero is complete, data from the zero calibration is displayed.
 - Press OK to accept the data and store the values.
 - Press ABORT to discard the data and return to the previous zero values.

Postrequisites

Restore normal flow through the sensor by opening the valves.

Need help? If the zero fails:

- Ensure that there is no flow through the sensor, then retry.
- Remove or reduce sources of electromechanical noise, then retry.
- Set Zero Time to a lower value, then retry.
- If the zero continues to fail, contact Micro Motion.
- If you want to return the flowmeter to operation using a previous zero value:
 - To restore the zero value set at the factory: Service Tools > Maintenance > Zero Calibration > Restore Factory Zero . This function requires the enhanced core processor.

Restriction

Restore the factory zero only if your flowmeter was purchased as a unit, it was zeroed at the factory, and you are using the original components.

11.4 Validate the meter

Display	OFF-LINE MAINT > CONFIG > UNITS > MTR F
ProLink II	ProLink > Configuration > Flow
ProLink III	Device Tools > Configuration > Process Measurement > Flow Device Tools > Configuration > Process Measurement > Density
Field Communicator	Configure > Manual Setup > Measurements > Flow Configure > Manual Setup > Measurements > Density

Overview

Meter validation compares flowmeter measurements reported by the transmitter to an external measurement standard. If the transmitter value for mass flow, volume flow, or density measurement is significantly different from the external measurement standard, you may want to adjust the corresponding meter factor. The flowmeter's actual measurement is multiplied by the meter factor, and the resulting value is reported and used in further processing.

Prerequisites

Identify the meter factor(s) that you will calculate and set. You may set any combination of the three meter factors: mass flow, volume flow, and density. Note that all three meter factors are independent:

- The meter factor for mass flow affects only the value reported for mass flow.
- The meter factor for density affects only the value reported for density.
- The meter factor for volume flow affects only the value reported for volume flow or gas standard volume flow.

Important

To adjust volume flow, you must set the meter factor for volume flow. Setting a meter factor for mass flow and a meter factor for density will not produce the desired result. The volume flow calculations are based on original mass flow and density values, before the corresponding meter factors have been applied.

If you plan to calculate the meter factor for volume flow, be aware that validating volume in the field may be expensive, and the procedure may be hazardous for some process fluids. Therefore, because volume is inversely proportional to density, an alternative to direct measurement is to calculate the meter factor for volume flow from the meter factor for density. See [Section 11.4.1](#) for instructions on this method.

Obtain a reference device (external measurement device) for the appropriate process variable.

Important

For good results, the reference device must be highly accurate.

Procedure

1. Determine the meter factor as follows:
 - a. Use the flowmeter to take a sample measurement.
 - b. Measure the same sample using the reference device.
 - c. Calculate the meter factor using the following formula:

$$\text{NewMeterFactor} = \text{ConfiguredMeterFactor} \times \frac{\text{ReferenceMeasurement}}{\text{FlowmeterMeasurement}}$$

2. Ensure that the calculated meter factor is between 0.8 and 1.2, inclusive. If the meter factor is outside these limits, contact Micro Motion customer service.
3. Configure the meter factor in the transmitter.

Example: Calculating the meter factor for mass flow

The flowmeter is installed and validated for the first time. The mass flow measurement from the transmitter is 250.27 lb. The mass flow measurement from the reference device is 250 lb. The mass flow meter factor is calculated as follows:

$$\text{MeterFactor}_{\text{MassFlow}} = 1 \times \frac{250}{250.27} = 0.9989$$

The first meter factor for mass flow is 0.9989.

One year later, the flowmeter is validated again. The mass flow measurement from the transmitter is 250.07 lb. The mass flow measurement from the reference device is 250.25 lb. The new mass flow meter factor is calculated as follows:

$$\text{MeterFactor}_{\text{MassFlow}} = 0.9989 \times \frac{250.25}{250.07} = 0.9996$$

The new meter factor for mass flow is 0.9996.

11.4.1 Alternate method for calculating the meter factor for volume flow

The alternate method for calculating the meter factor for volume flow is used to avoid the difficulties that may be associated with the standard method.

This alternate method is based on the fact that volume is inversely proportional to density. It provides partial correction of the volume flow measurement by adjusting for the portion of the total offset that is caused by the density measurement offset. Use this method only when a volume flow reference is not available, but a density reference is available.

Procedure

1. Calculate the meter factor for density, using the standard method (see [Section 11.4](#)).
2. Calculate the meter factor for volume flow from the meter factor for density:

$$\text{MeterFactor}_{\text{Volume}} = \frac{1}{\text{MeterFactor}_{\text{Density}}}$$

Note

The following equation is mathematically equivalent to the first equation. You may use whichever version you prefer.

$$\text{MeterFactor}_{\text{Volume}} = \text{ConfiguredMeterFactor}_{\text{Density}} \times \frac{\text{Density}_{\text{Flowmeter}}}{\text{Density}_{\text{ReferenceDevice}}}$$

3. Ensure that the calculated meter factor is between 0.8 and 1.2, inclusive. If the meter factor is outside these limits, contact Micro Motion customer service.
4. Configure the meter factor for volume flow in the transmitter.

11.5 Perform a (standard) D1 and D2 density calibration

Density calibration establishes the relationship between the density of the calibration fluids and the signal produced at the sensor. Density calibration includes the calibration of the D1 (low-density) and D2 (high-density) calibration points.

Important

Micro Motion flowmeters are calibrated at the factory, and normally do not need to be calibrated in the field. Calibrate the flowmeter only if you must do so to meet regulatory requirements. Contact Micro Motion before calibrating the flowmeter.

Tip

Micro Motion recommends using meter validation and meter factors, rather than calibration, to prove the meter against a regulatory standard or to correct measurement error.

11.5.1 Perform a D1 and D2 density calibration using ProLink II

Prerequisites

- During density calibration, the sensor must be completely filled with the calibration fluid, and flow through the sensor must be at the lowest rate allowed by your application. This is usually accomplished by closing the shutoff valve downstream from the sensor, then filling the sensor with the appropriate fluid.
- D1 and D2 density calibration require a D1 (low-density) fluid and a D2 (high-density) fluid. You may use air and water.

- If LD Optimization is enabled on your meter, disable it. To do this, choose ProLink > Configuration > Sensor and ensure that the checkbox is not checked. LD Optimization is used only with large sensors in hydrocarbon applications. In some installations, only Micro Motion customer service has access to this parameter. If this is the case, contact Micro Motion before continuing.
- The calibrations must be performed without interruption, in the order shown. Make sure that you are prepared to complete the process without interruption.
- Before performing the calibration, record your current calibration parameters. You can do this by saving the current configuration to a file on the PC. If the calibration fails, restore the known values.

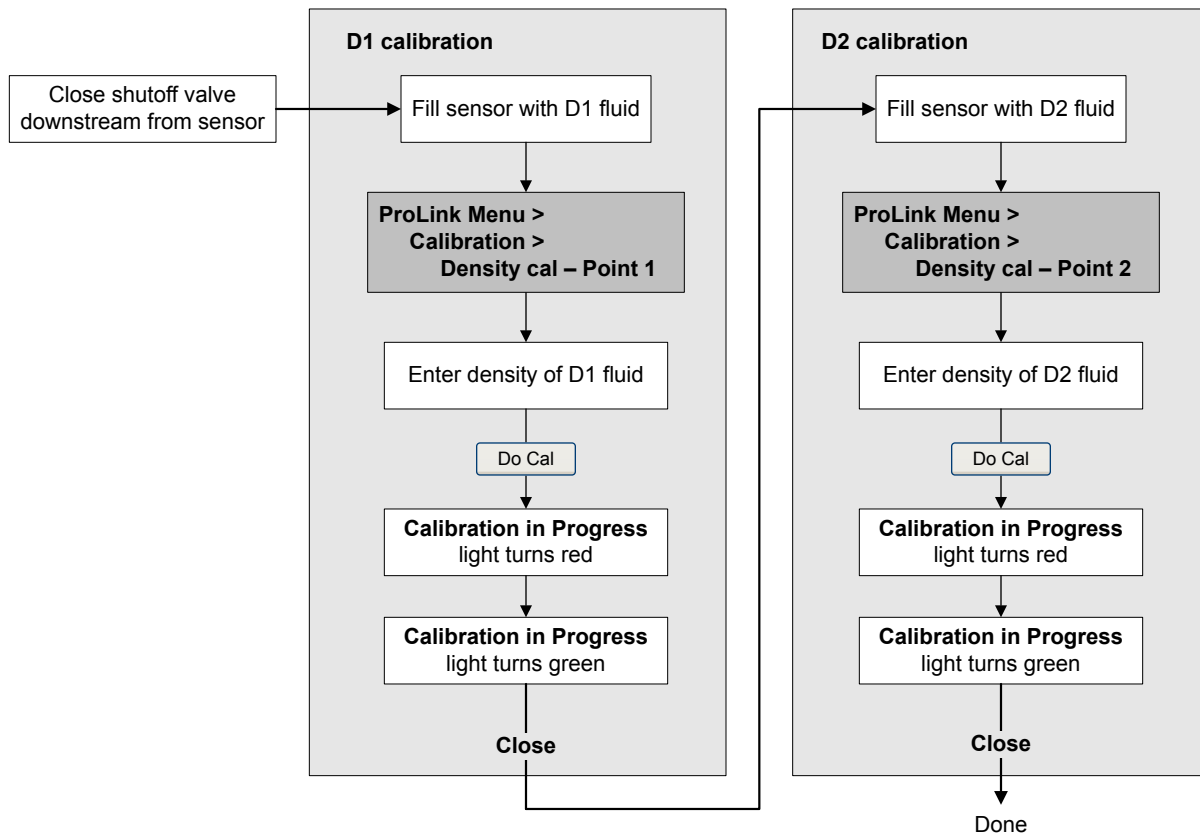
Restriction

For T-Series sensors, the D1 calibration must be performed on air and the D2 calibration must be performed on water.

Procedure

See [Figure 11-7](#).

Figure 11-7: D1 and D2 density calibration using ProLink II



Postrequisites

If you disabled LD Optimization before the calibration procedure, re-enable it.

11.5.2 Perform a D1 and D2 density calibration using ProLink III

Prerequisites

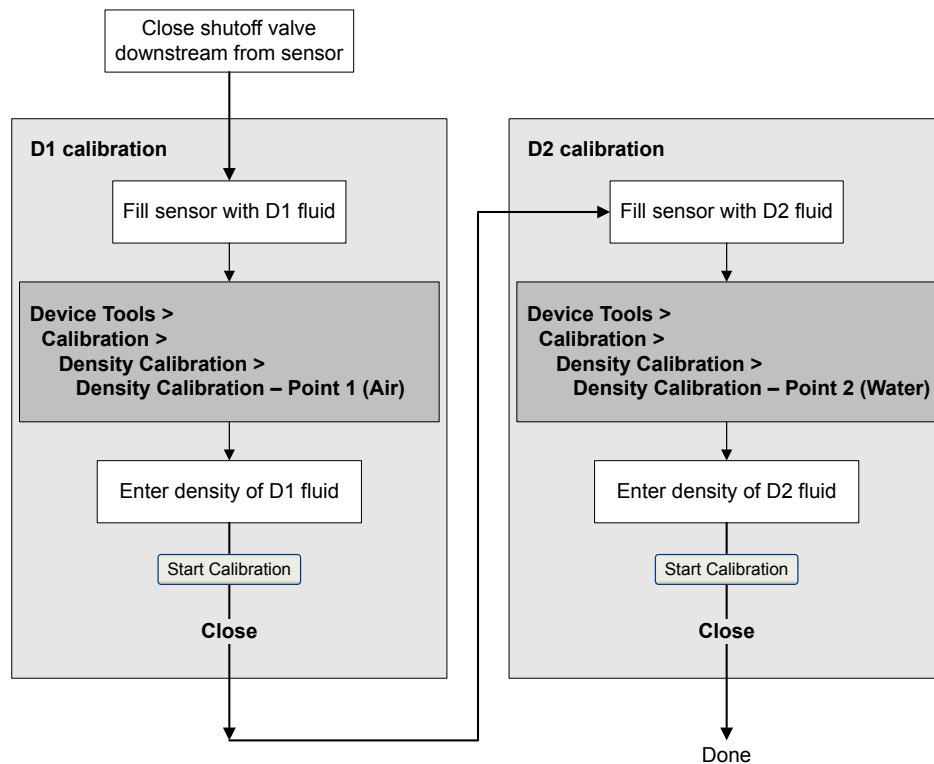
- During density calibration, the sensor must be completely filled with the calibration fluid, and flow through the sensor must be at the lowest rate allowed by your application. This is usually accomplished by closing the shutoff valve downstream from the sensor, then filling the sensor with the appropriate fluid.
- D1 and D2 density calibration require a D1 (low-density) fluid and a D2 (high-density) fluid. You may use air and water.
- If LD Optimization is enabled on your meter, disable it. To do this, choose Device Tools > Configuration > LD Optimization. LD Optimization is used only with large sensors in hydrocarbon applications. In some installations, only Micro Motion customer service has access to this parameter. If this is the case, contact Micro Motion before continuing.
- The calibrations must be performed without interruption, in the order shown. Make sure that you are prepared to complete the process without interruption.
- Before performing the calibration, record your current calibration parameters. You can do this by saving the current configuration to a file on the PC. If the calibration fails, restore the known values.

Restriction

For T-Series sensors, the D1 calibration must be performed on air and the D2 calibration must be performed on water.

Procedure

See [Figure 11-8](#).

Figure 11-8: D1 and D2 density calibration using ProLink III**Postrequisites**

If you disabled LD Optimization before the calibration procedure, re-enable it.

11.5.3 Perform a D1 and D2 density calibration using the Field Communicator

Prerequisites

- During density calibration, the sensor must be completely filled with the calibration fluid, and flow through the sensor must be at the lowest rate allowed by your application. This is usually accomplished by closing the shutoff valve downstream from the sensor, then filling the sensor with the appropriate fluid.
- D1 and D2 density calibration require a D1 (low-density) fluid and a D2 (high-density) fluid. You may use air and water.
- If LD Optimization is enabled on your meter, disable it. To do this, choose **Configure > Manual Setup > Measurements > LD Optimization**. LD Optimization is used only with large sensors in hydrocarbon applications. In some installations, only Micro Motion customer service has access to this parameter. If this is the case, contact Micro Motion before continuing.
- The calibrations must be performed without interruption, in the order shown. Make sure that you are prepared to complete the process without interruption.

- Before performing the calibration, record your current calibration parameters. If the calibration fails, restore the known values.

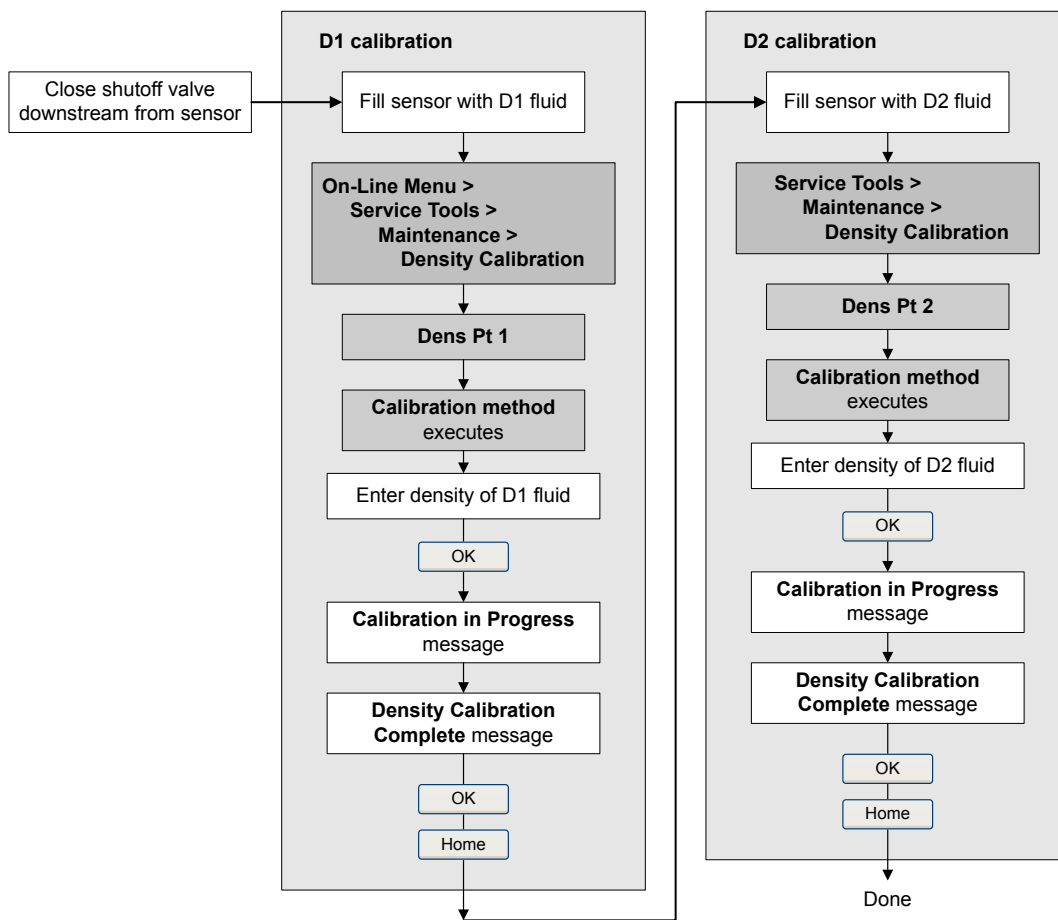
Restriction

For T-Series sensors, the D1 calibration must be performed on air and the D2 calibration must be performed on water.

Procedure

See [Figure 11-9](#).

Figure 11-9: D1 and D2 density calibration using the Field Communicator



Postrequisites

If you disabled LD Optimization before the calibration procedure, re-enable it.

11.6 Perform a D3 and D4 density calibration (T-Series sensors only)

For T-Series sensors, the optional D3 and D4 calibration could improve the accuracy of the density measurement if the density of your process fluid is less than 0.8 g/cm^3 or greater than 1.2 g/cm^3 .

If you perform the D3 and D4 calibration, note the following:

- Do not perform the D1 and D2 calibration.
- Perform the D3 calibration if you have one calibrated fluid.
- Perform both the D3 and D4 calibrations if you have two calibrated fluids (other than air and water). The calibrations must be performed without interruption, in the order shown. Make sure that you are prepared to complete the process without interruption.

11.6.1 Perform a D3 or D3 and D4 density calibration using ProLink II

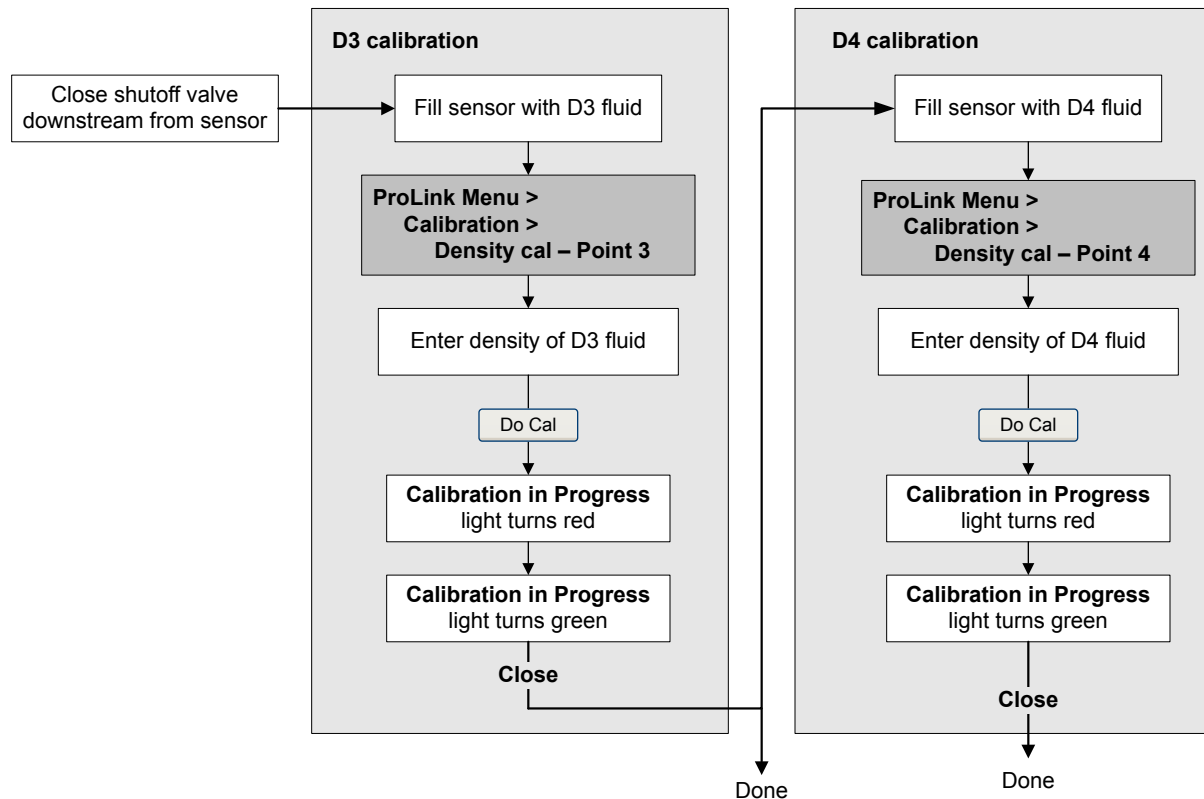
Prerequisites

- During density calibration, the sensor must be completely filled with the calibration fluid, and flow through the sensor must be at the lowest rate allowed by your application. This is usually accomplished by closing the shutoff valve downstream from the sensor, then filling the sensor with the appropriate fluid.
- For D3 density calibration, the D3 fluid must meet the following requirements:
 - Minimum density of 0.6 g/cm^3
 - Minimum difference of 0.1 g/cm^3 between the density of the D3 fluid and the density of water. The density of the D3 fluid may be either greater or less than the density of water.
- For D4 density calibration, the D4 fluid must meet the following requirements:
 - Minimum density of 0.6 g/cm^3
 - Minimum difference of 0.1 g/cm^3 between the density of the D4 fluid and the density of the D3 fluid. The density of the D4 fluid must be greater than the density of the D3 fluid.
 - Minimum difference of 0.1 g/cm^3 between the density of the D4 fluid and the density of water. The density of the D4 fluid may be either greater or less than the density of water.
- Before performing the calibration, record your current calibration parameters. You can do this by saving the current configuration to a file on the PC. If the calibration fails, restore the known values.

Procedure

See [Figure 11-10](#).

Figure 11-10: D3 or D3 and D4 density calibration using ProLink II



11.6.2 Perform a D3 or D3 and D4 density calibration using ProLink III

Prerequisites

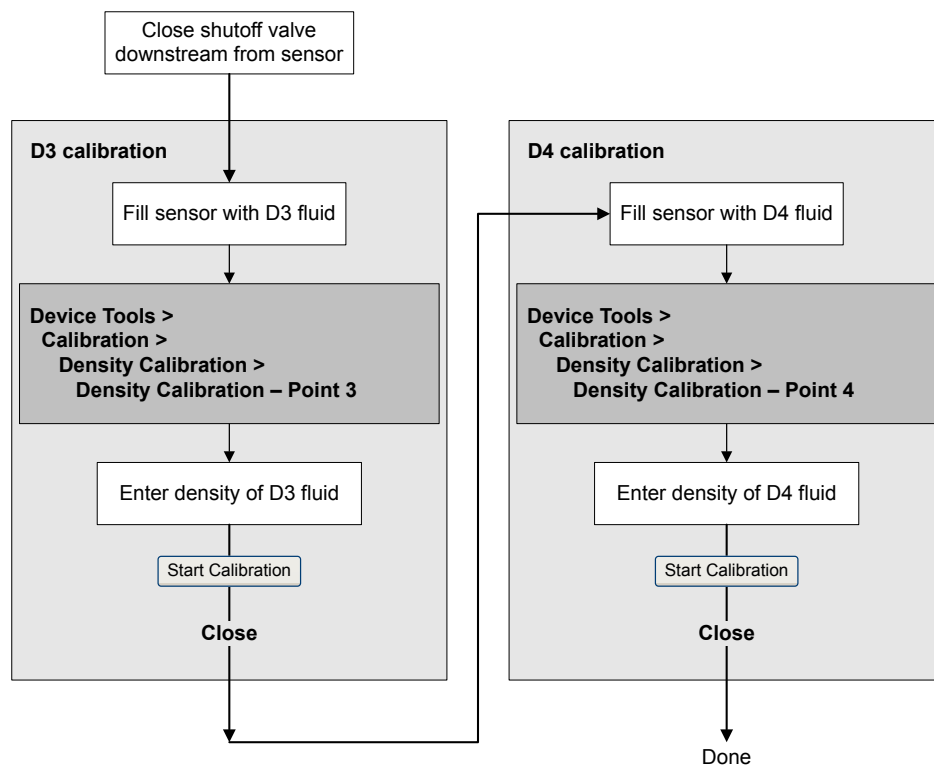
- During density calibration, the sensor must be completely filled with the calibration fluid, and flow through the sensor must be at the lowest rate allowed by your application. This is usually accomplished by closing the shutoff valve downstream from the sensor, then filling the sensor with the appropriate fluid.
- For D3 density calibration, the D3 fluid must meet the following requirements:
 - Minimum density of 0.6 g/cm^3
 - Minimum difference of 0.1 g/cm^3 between the density of the D3 fluid and the density of water. The density of the D3 fluid may be either greater or less than the density of water.
- For D4 density calibration, the D4 fluid must meet the following requirements:
 - Minimum density of 0.6 g/cm^3

- Minimum difference of 0.1 g/cm^3 between the density of the D4 fluid and the density of the D3 fluid. The density of the D4 fluid must be greater than the density of the D3 fluid.
- Minimum difference of 0.1 g/cm^3 between the density of the D4 fluid and the density of water. The density of the D4 fluid may be either greater or less than the density of water.
- Before performing the calibration, record your current calibration parameters. You can do this by saving the current configuration to a file on the PC. If the calibration fails, restore the known values.

Procedure

See [Figure 11-11](#).

Figure 11-11: D3 or D3 and D4 density calibration using ProLink III



11.6.3 Perform a D3 or D3 and D4 density calibration using the Field Communicator

Prerequisites

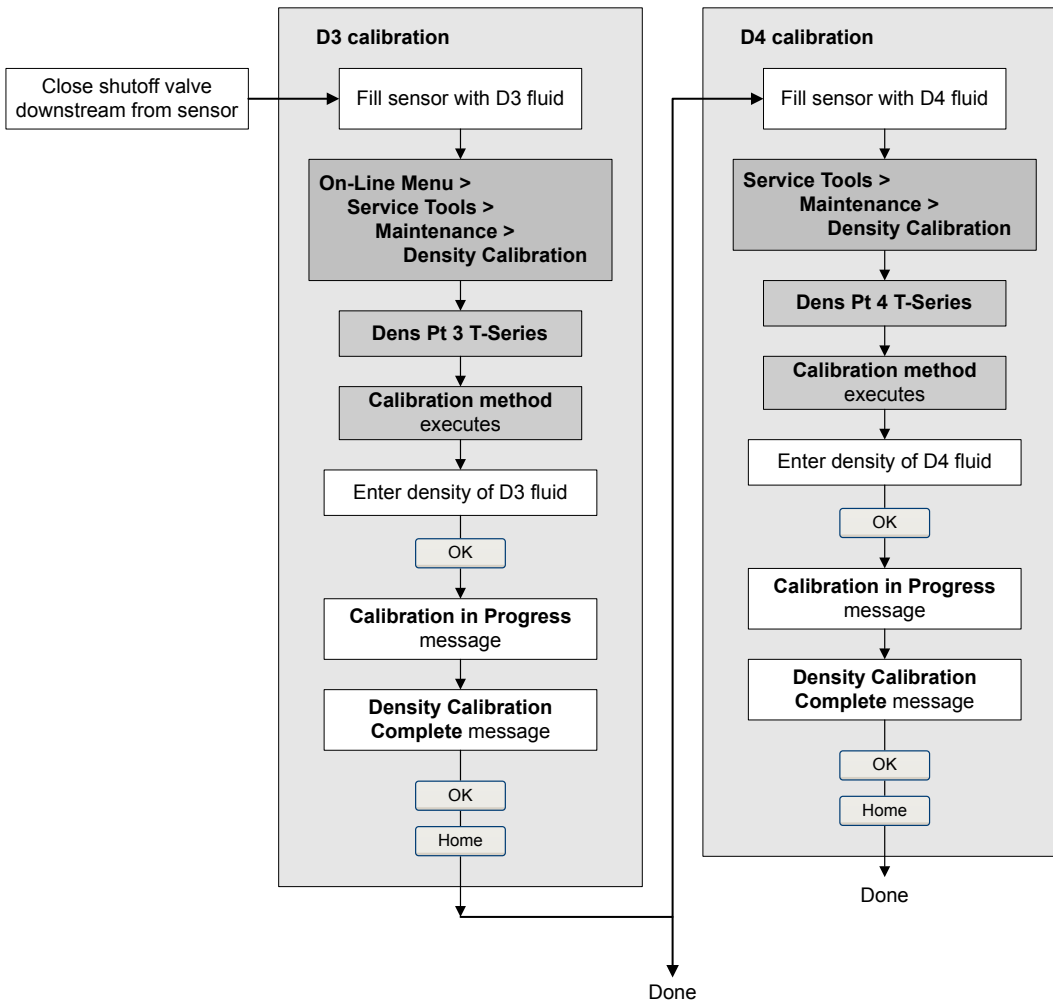
- During density calibration, the sensor must be completely filled with the calibration fluid, and flow through the sensor must be at the lowest rate allowed by your application. This is usually accomplished by closing the shutoff valve downstream from the sensor, then filling the sensor with the appropriate fluid.

- For D3 density calibration, the D3 fluid must meet the following requirements:
 - Minimum density of 0.6 g/cm^3
 - Minimum difference of 0.1 g/cm^3 between the density of the D3 fluid and the density of water. The density of the D3 fluid may be either greater or less than the density of water.
- For D4 density calibration, the D4 fluid must meet the following requirements:
 - Minimum density of 0.6 g/cm^3
 - Minimum difference of 0.1 g/cm^3 between the density of the D4 fluid and the density of the D3 fluid. The density of the D4 fluid must be greater than the density of the D3 fluid.
 - Minimum difference of 0.1 g/cm^3 between the density of the D4 fluid and the density of water. The density of the D4 fluid may be either greater or less than the density of water.
- Before performing the calibration, record your current calibration parameters. If the calibration fails, restore the known values.

Procedure

See [Figure 11-12](#).

Figure 11-12: D3 or D3 and D4 density calibration using the Field Communicator



11.7 Perform temperature calibration

Temperature calibration establishes the relationship between the temperature of the calibration fluids and the signal produced by the sensor.

Prerequisites

The temperature calibration is a two-part procedure: temperature offset calibration and temperature slope calibration. The two parts must be performed without interruption, in the order shown. Make sure that you are prepared to complete the process without interruption.

You must use ProLink II or ProLink III to calibrate for temperature.

Important

Consult Micro Motion before performing a temperature calibration. Under normal circumstances, the temperature circuit is stable and should not need an adjustment.

Procedure

See [Figure 11-13](#) and [Figure 11-14](#).

Figure 11-13: Temperature calibration using ProLink II

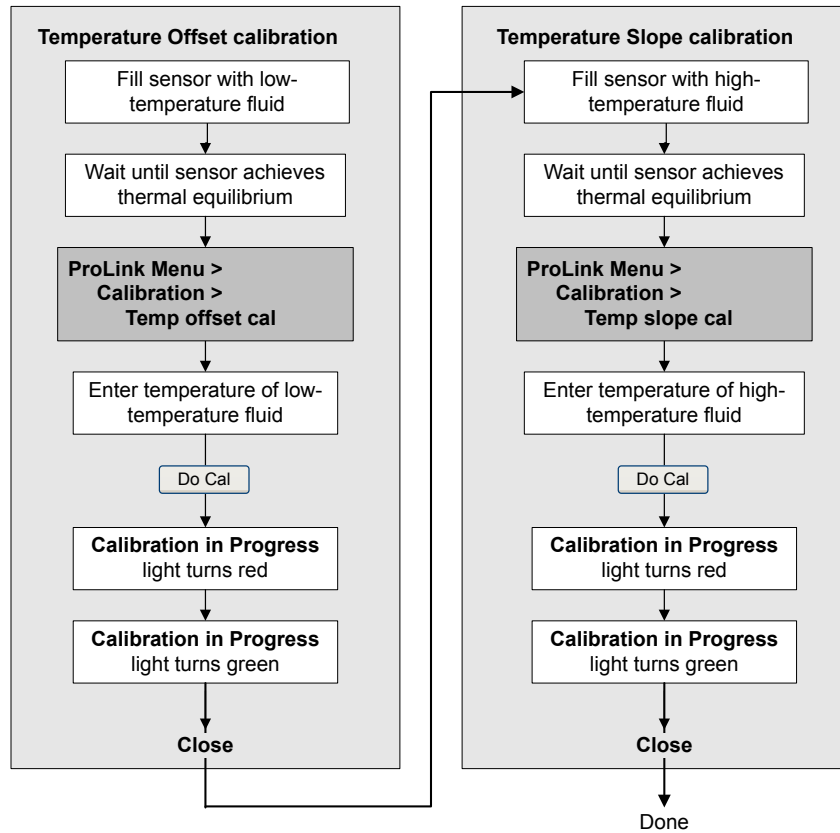
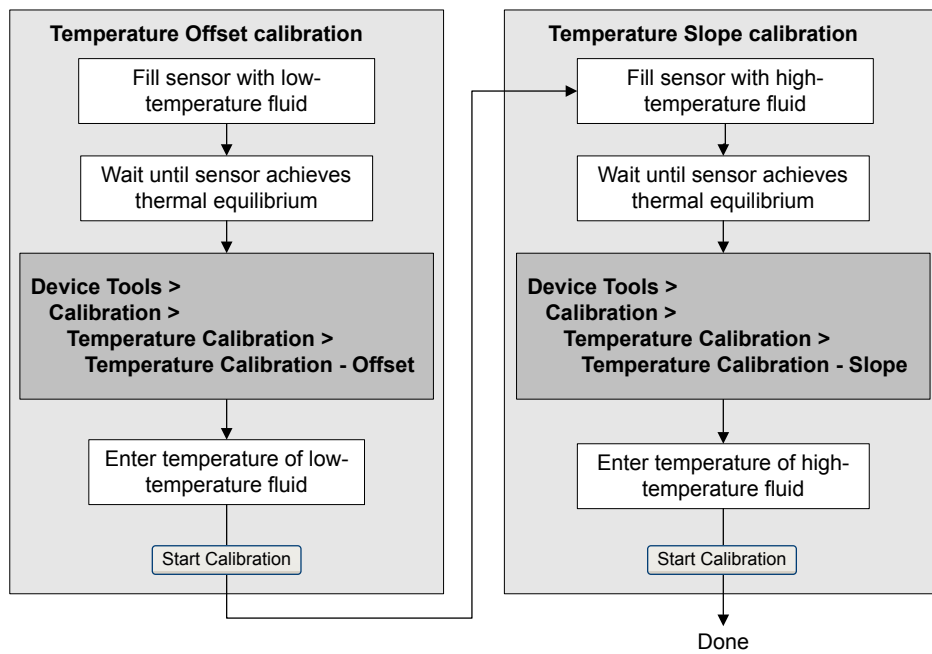


Figure 11-14: Temperature calibration using ProLink III

12 Troubleshooting

Topics covered in this chapter:

- *Status LED states*
- *Status alarms*
- *Flow measurement problems*
- *Density measurement problems*
- *Temperature measurement problems*
- *Milliamp output problems*
- *Frequency output problems*
- *Use sensor simulation for troubleshooting*
- *Check power supply wiring*
- *Check sensor-to-transmitter wiring*
- *Check grounding*
- *Perform loop tests*
- *Check for radio frequency interference (RFI)*
- *Check the HART communication loop*
- *Check HART Address and Loop Current Mode*
- *Check HART burst mode*
- *Check the trimming of the mA output*
- *Check Lower Range Value and Upper Range Value*
- *Check mA Output Fault Action*
- *Check Frequency Output Maximum Pulse Width*
- *Check Frequency Output Scaling Method*
- *Check Frequency Output Fault Action*
- *Check Flow Direction*
- *Check the cutoffs*
- *Check for slug flow (two-phase flow)*
- *Check the drive gain*
- *Check the pickoff voltage*
- *Check for electrical shorts*
- *Check the core processor LED*
- *Perform a core processor resistance test*

12.1 Status LED states

The status LED on the transmitter indicates whether or not alarms are active. If alarms are active, view the alarm list to identify the alarms, then take appropriate action to correct the alarm condition.

Your transmitter has a status LED only if it has a display.

If the transmitter has a display and LED Blinking is disabled, the status LED does not flash to indicate an unacknowledged alarm.

Table 12-1: Status LED states

Condition	LED Blinking parameter	LED behavior
Normal operation (no alarm)	N/A	Solid green
Unacknowledged corrected condition (no alarm)	Enabled	Flashing green
	Disabled	Solid green
Acknowledged low-severity alarm (outputs continue to report process data)	N/A	Solid yellow
Unacknowledged low-severity alarm (outputs continue to report process data)	Enabled	Flashing yellow
	Disabled	Solid yellow
Acknowledged high-severity alarm (outputs in fault)	N/A	Solid red
Unacknowledged high-severity alarm (outputs in fault)	Enabled	Flashing red
	Disabled	Solid red

12.2 Status alarms

Table 12-2: Status alarms and recommended actions

Alarm code	Description	Recommended actions
A001	EEPROM Error (Core Processor)	The transmitter has detected a problem communicating with the sensor. You can try cycling power to the meter to see if the condition clears. If not, the core processor must be replaced.
A002	RAM Error (Core Processor)	The transmitter has detected a problem communicating with the sensor. You can try cycling power to the meter to see if the condition clears. If not, the core processor must be replaced.

Table 12-2: Status alarms and recommended actions (continued)

Alarm code	Description	Recommended actions
A003	No Sensor Response	<p>The transmitter is not receiving one or more basic electrical signals from the sensor. This could mean that the wiring between the sensor and the transmitter has been damaged, or that the sensor requires factory service.</p> <ol style="list-style-type: none"> 1. Check the drive gain and pickoff voltage. (See Section 12.26 and Section 12.27.) 2. Check the wiring between the sensor and the transmitter. <ol style="list-style-type: none"> a. Using the installation manual for your transmitter, verify that the transmitter is connected to the sensor according to the instructions. Obey all safety messages when opening wiring compartments. b. Verify that the wires are making good contact with the terminals. c. Perform RTD resistance checks and check for shorts to case (see Section 12.28.1). d. Check the continuity of all wires from the transmitter to the sensor. 3. Check for electrical shorts. See Section 12.28. 4. Check the integrity of the sensor tubes.
A004	Temperature Overrange	<p>The sensor RTD is signaling a resistance that is out of range for the sensor.</p> <ol style="list-style-type: none"> 1. Check the sensor RTD resistance values and for RTD shorts to case. (See Section 12.28.1.) 2. Check the wiring between the sensor and the transmitter. <ol style="list-style-type: none"> a. Using the installation manual for your transmitter, verify that the transmitter is connected to the sensor according to the instructions. Obey all safety messages when opening wiring compartments. b. Verify that the wires are making good contact with the terminals. c. Perform RTD resistance checks and check for shorts to case (see Section 12.28.1). d. Check the continuity of all wires from the transmitter to the sensor. 3. Verify temperature characterization parameters (Temp Cal Factor). 4. Check your process conditions against the values reported by the flowmeter.

Table 12-2: Status alarms and recommended actions (continued)

Alarm code	Description	Recommended actions
A005	Mass Flow Rate Overage	<p>The sensor is signaling a flow rate that is out of range for the sensor.</p> <ol style="list-style-type: none"> 1. If other alarms are present, resolve those alarm conditions first. If the current alarm persists, continue with the recommended actions. 2. Check your process conditions against the values reported by the flowmeter. 3. Check for slug flow (two-phase flow). <ol style="list-style-type: none"> a. Check for slug flow alarms. If slug flow is the problem, alarms will be posted. b. Check the process for cavitation, flashing, or leaks. c. Monitor the density of your process fluid output under normal process conditions.
A006	Characterization Required	<p>The calibration factors for the sensor have not been entered, or the sensor type is incorrect, or the calibration factors are incorrect for the sensor type.</p> <ol style="list-style-type: none"> 1. Verify that all of the characterization parameters match the data on the sensor tag. 2. Check the resistance of the LLC. (See Section 12.28.1.) 3. Check the Sensor Type parameter and make sure it matches your sensor type. 4. If Sensor Type is Curved Tube, make sure that none of the parameters specific to Straight Tube sensors have been set. 5. If all of the parameters are correct and the alarm persists, replace the core processor.

Table 12-2: Status alarms and recommended actions (continued)

Alarm code	Description	Recommended actions
A008	Density Overrange	<p>The sensor is signaling a density reading below 0 g/cm³ or above 10 g/cm³. Common causes for this alarm include partially filled flow tubes, excessive gas entrainment or flashing, tube fouling (foreign material stuck in a tube, uneven coating on the inside of a tube, or a plugged tube), or tube deformation (a permanent change in tube geometry due to overpressure or hammer effect).</p> <ol style="list-style-type: none"> 1. If other alarms are present, resolve those alarm conditions first. If the current alarm persists, continue with the recommended actions. 2. Check your process conditions against the values reported by the flowmeter. 3. Check for air in the flow tubes, tubes not filled, foreign material in the tubes, or coating in the tubes. 4. Check for slug flow (two-phase flow). <ol style="list-style-type: none"> a. Check for slug flow alarms. If slug flow is the problem, alarms will be posted. b. Check the process for cavitation, flashing, or leaks. c. Monitor the density of your process fluid output under normal process conditions. d. Check the values of Slug Low Limit, Slug High Limit, and Slug Duration. 5. If accompanied by an A003 alarm, check for electrical shorts between sensor terminals or between the sensor terminals and the sensor case. 6. Verify that all of the characterization parameters match the data on the sensor tag. 7. Check the sensor coils (see Section 12.28.1). 8. Check the drive gain and pickoff voltage. 9. Perform a density calibration. 10. Contact Micro Motion.
A009	Transmitter Initializing/Warming Up	<p>The transmitter is in power-up mode. Allow the transmitter to warm up. The alarm should clear automatically.</p> <p>If the alarm does not clear:</p> <ol style="list-style-type: none"> 1. Check that there is sufficient voltage at the core processor. A minimum of 11.5 VDC should be available at the core terminals at all times. If there is insufficient power on the core terminals, check that the transmitter is receiving sufficient power on the power terminals. 2. Make sure the sensor tubes are full of process fluid. 3. Check the wiring between the sensor and the transmitter.

Table 12-2: Status alarms and recommended actions (continued)

Alarm code	Description	Recommended actions
A010	Calibration Failure	<p>This alarm is typically caused by flow through the sensor during the zero, or by a zero offset result that is out of range. Power to the transmitter must be cycled to clear this alarm.</p> <ol style="list-style-type: none"> 1. Cycle power to the meter. 2. Make sure there is no flow through the sensor. 3. Retry the zero calibration. 4. Power-cycle the transmitter.
A011	Zero Calibration Failed: Low	<p>This alarm is caused by reverse flow in the sensor during the zero, or by a zero offset result that is below the valid range. This alarm will be accompanied by A010. Power to the transmitter must be cycled to clear this alarm.</p> <ol style="list-style-type: none"> 1. Cycle power to the meter. 2. Make sure there is no flow through the sensor. 3. Retry the zero calibration. 4. Power-cycle the transmitter.
A012	Zero Calibration Failed: High	<p>This alarm is caused by positive flow in the sensor during the zero, or by a zero offset result that is above the valid range. This alarm will be accompanied by A010. Power to the transmitter must be cycled to clear this alarm.</p> <ol style="list-style-type: none"> 1. Cycle power to the meter. 2. Make sure there is no flow through the sensor. 3. Retry the zero calibration. 4. Power-cycle the transmitter.
A013	Zero Calibration Failed: Unstable	<p>There was too much instability during the calibration procedure. Power to the transmitter must be cycled to clear this alarm.</p> <ol style="list-style-type: none"> 1. Remove or reduce sources of electromechanical noise (e.g., pumps, vibration, pipe stress). <ul style="list-style-type: none"> • Check the drive gain and pickoff voltages to confirm that the sensor is in a stable state. • Retry the procedure. 2. Cycle power to the meter, then retry the procedure.
A014	Transmitter Failure	<ol style="list-style-type: none"> 1. Check that all wiring compartment covers are installed properly. 2. Check that the wiring connected to the transmitter meets specifications and that all cable shields are properly terminated. 3. Check that the sensor and transmitter are both grounded properly. 4. Evaluate the environment for sources of high electromagnetic interference (EMI) and relocate the transmitter or wiring as necessary.

Table 12-2: Status alarms and recommended actions (continued)

Alarm code	Description	Recommended actions
A016	Sensor RTD Failure	<p>The sensor RTD is signaling a resistance that is out of range for the sensor.</p> <ol style="list-style-type: none"> 1. Check the wiring between the sensor and the transmitter. <ol style="list-style-type: none"> a. Using the installation manual for your transmitter, verify that the transmitter is connected to the sensor according to the instructions. Obey all safety messages when opening wiring compartments. b. Verify that the wires are making good contact with the terminals. c. Perform RTD resistance checks and check for shorts to case (see Section 12.28.1). d. Check the continuity of all wires from the transmitter to the sensor. 2. Check your process conditions against the values reported by the flowmeter. 3. Contact Micro Motion.
A017	T-Series RTD Failure	<p>The sensor RTD is signaling a resistance that is out of range for the sensor.</p> <ol style="list-style-type: none"> 1. Check the wiring between the sensor and the transmitter. <ol style="list-style-type: none"> a. Using the installation manual for your transmitter, verify that the transmitter is connected to the sensor according to the instructions. Obey all safety messages when opening wiring compartments. b. Verify that the wires are making good contact with the terminals. c. Perform RTD resistance checks and check for shorts to case (see Section 12.28.1). d. Check the continuity of all wires from the transmitter to the sensor. 2. Check your process conditions against the values reported by the flowmeter. Temperature should be between -200°F and $+400^{\circ}\text{F}$. 3. Verify that all of the characterization parameters match the data on the sensor tag. 4. Contact Micro Motion.
A018	EEPROM Error (Transmitter)	<p>Power to the transmitter must be cycled to clear this alarm.</p> <ol style="list-style-type: none"> 1. Check that all wiring compartment covers are installed properly. 2. Check that the wiring connected to the transmitter meets specifications and that shields are properly terminated. 3. Check that the sensor and transmitter are both grounded properly. 4. Evaluate the environment for sources of high electromagnetic interference (EMI) and relocate the transmitter or wiring as necessary. 5. Cycle power to the transmitter. 6. If the problem persists, replace the transmitter.

Table 12-2: Status alarms and recommended actions (continued)

Alarm code	Description	Recommended actions
A019	RAM Error (Transmitter)	Power to the transmitter must be cycled to clear this alarm. <ol style="list-style-type: none"> 1. Check that all wiring compartment covers are installed properly. 2. Check that the wiring connected to the transmitter meets specifications and that shields are properly terminated. 3. Check that the sensor and transmitter are both grounded properly. 4. Evaluate the environment for sources of high electromagnetic interference (EMI) and relocate the transmitter or wiring as necessary. 5. Cycle power to the transmitter. 6. If the problem persists, replace the transmitter.
A020	No Flow Cal Value	The flow calibration factor and/or K1 has not been entered since the last master reset. Verify that all of the characterization parameters match the data on the sensor tag. If the problem persists: <ol style="list-style-type: none"> 1. Check that the sensor type (curved or straight) is properly selected. 2. Confirm that no "T-series" calibration parameters have been set if this is a curved tube sensor.
A021	Incorrect Sensor Type (K1)	The sensor is recognized as a straight tube but the K1 value indicates a curved tube, or vice versa. Verify that all of the characterization parameters match the data on the sensor tag. If the problem persists: <ol style="list-style-type: none"> 1. Check that the sensor type (curved or straight) is properly selected. 2. Confirm that no "T-Series" calibration parameters have been set if this is a curved tube sensor. 3. If this alarm occurs in conjunction with A006, check the LLC resistance and for shorts to case (Section 12.28.1).
A022	Configuration Database Corrupt (Core Processor)	Try cycling power to the meter to see if the alarm clears. If the alarm persists, replace the core processor.
A023	Internal Totals Corrupt (Core Processor)	Try cycling power to the meter to see if the alarm clears. If the alarm persists, replace the core processor.
A024	Program Corrupt (Core Processor)	Try cycling power to the meter to see if the alarm clears. If the alarm persists, replace the core processor.
A025	Boot Sector Fault (Core Processor)	Try cycling power to the meter to see if the alarm clears. If the alarm persists, replace the core processor.

Table 12-2: Status alarms and recommended actions (continued)

Alarm code	Description	Recommended actions
A026	Sensor/Transmitter Communications Failure	<p>The transmitter has lost communication with the core processor on the sensor. This alarm can be an indication of a problem with the core or the transmitter requiring the replacement of one or both parts.</p> <ol style="list-style-type: none"> 1. Check the wiring between the sensor and the transmitter. <ol style="list-style-type: none"> a. Using the installation manual for your transmitter, verify that the transmitter is connected to the sensor according to the instructions. Obey all safety messages when opening wiring compartments. b. Verify that the wires are making good contact with the terminals. c. Perform RTD resistance checks and check for shorts to case (see Section 12.28.1). d. Check the continuity of all wires from the transmitter to the sensor. 2. Check the core processor LED. 3. If no definite correctable cause was found, replace the core processor. <ol style="list-style-type: none"> a. If the problem persists, put back the original core processor and replace the transmitter. b. If the problem still persists, replace both the transmitter and core processor.
A027	Security Breach	<ol style="list-style-type: none"> 1. Check the HART device ID. 2. The transmitter has a weights and measures security feature that is currently set to “unsecure.” Set the transmitter to “secure” to clear the alarm. An authorized procedure may be required to resecure the transmitter.
A028	Core Processor Write Failure	<p>There has been a failure in the transmitter electronics. Try cycling power to the meter to see if the alarm clears. If the alarm persists, replace the core processor.</p>
A029	PIC/Daughterboard Communications Failure	<p>This can be an indication that there has been a loss of communication between the transmitter and the display module. Try cycling power to the meter to see if the alarm clears. If possible, replace the display module.</p>
A030	Incorrect Board Type	<p>The firmware or configuration loaded in the transmitter is incompatible with the board type. If this alarm occurred in conjunction with an effort to load a configuration into the transmitter, confirm that the transmitter is of the same model as the one the configuration came from.</p> <p>Try cycling power to the meter to see if the alarm clears. If the problem persists, contact Micro Motion for additional assistance.</p>

Table 12-2: Status alarms and recommended actions (continued)

Alarm code	Description	Recommended actions
A031	Low Power	<p>The core processor on the sensor is not receiving sufficient power. Check the wiring between the transmitter and the sensor. Power to the transmitter must be cycled to clear this alarm.</p> <ol style="list-style-type: none"> 1. Using the installation manual for your transmitter, verify that the transmitter is connected to the sensor according to the instructions. Obey all safety messages when opening wiring compartments. 2. Verify that the wires are making good contact with the terminals. 3. Check the continuity of all wires from the transmitter to the sensor. 4. Cycle power to the meter, then retry the procedure. 5. Measure the voltage at the core processor terminals. There should be a minimum of 11.5 volts at all times. <ol style="list-style-type: none"> a. If there is less than 11.5 volts, confirm that the transmitter is receiving sufficient voltage. (You may need to refer to the installation manual.) b. If the transmitter is receiving sufficient voltage, and the problem still persists, replace the transmitter.
A032	Meter Verification in Progress: Outputs to Fault	Meter verification in progress, with outputs set to Fault or Last Measured Value.
A033	Insufficient Right/Left Pickoff Signal	<p>There is insufficient signal coming from the sensor pickoff coils, which suggests that the sensor tubes are being prevented from vibrating at their natural frequency. This alarm often appears in conjunction with alarm A102.</p> <ol style="list-style-type: none"> 1. Check for possible fluid separation by monitoring the density value and comparing the results against expected density values. 2. Check for plugging, coating, or slug flow. 3. Settling from a two-phase or three-phase fluid can cause this alarm even if the flow tubes are full. This could mean that the sensor needs to be reoriented. Refer to the sensor installation manual for recommended sensor orientations.
A035	Meter Verification Aborted	<p>The Meter Verification test did not complete, possibly because it was manually aborted.</p> <ol style="list-style-type: none"> 1. Verify that process conditions are stable, then retry the test. 2. Contact Micro Motion.

Table 12-2: Status alarms and recommended actions (continued)

Alarm code	Description	Recommended actions
A100	mA Output 1 Saturated	The calculated mA output value is outside of the meter's configured range. <ol style="list-style-type: none"> 1. Check the Upper Range Value and Lower Range Value parameters. Are they set correctly? 2. Check your process conditions against the values reported by the flowmeter. 3. Verify that the measurement units are configured correctly for your application. 4. Purge the flow tubes. 5. Verify process conditions, checking especially for air in the flow tubes, tubes not filled, foreign material in the tubes, or coating in the tubes.
A101	mA Output 1 Fixed	Non-zero HART address configured, or the mA output is configured to send a constant value. <ol style="list-style-type: none"> 1. Check whether the output is in loop test mode. If it is, unfix the output. 2. Exit mA output trim, if applicable. 3. Check the HART polling address. 4. Check whether the output has been set to a constant value via digital communication.
A102	Drive Overrange	The drive power (current/voltage) is at its maximum. <ol style="list-style-type: none"> 1. Check the drive gain and pickoff voltage. 2. Check for electrical shorts between sensor terminals or between the sensor terminals and the sensor case. 3. Check for partially filled tubes, tube fouling, damaged tubes, and excessive air entrainment or flashing. 4. Settling from a two- or three-phase fluid could create this alarm even if the flow tubes are full, which could mean the sensor needs to be reoriented. Refer to the sensor installation manual for recommended sensor orientations.
A103	Data Loss Possible (Totals and Inventories)	The totalizers are not being saved properly. The core processor was unable to store the totalizers on the last power-down and must rely on the saved totals. The saved totals can be as much as two hours out of date. <ol style="list-style-type: none"> 1. Make sure the transmitter and core processor are receiving sufficient power. 2. Check the power supply and power supply wiring.
A104	Calibration in Progress	A calibration procedure is in process.
A105	Slug Flow	The density of the process has exceeded the user-defined density limits. Check for slug flow (two-phase flow).
A106	Burst Mode Enabled	HART burst mode is enabled.
A107	Power Reset Occurred	The transmitter has been restarted.
A108	Basic Event 1 On	No action required.
A109	Basic Event 2 On	No action required.

Table 12-2: Status alarms and recommended actions (continued)

Alarm code	Description	Recommended actions
A110	Frequency Output Saturated	<p>The calculated frequency output is outside the configured range.</p> <ol style="list-style-type: none"> 1. Check the Frequency Output Scaling Method parameter. 2. Check your process conditions against the values reported by the flowmeter. 3. Verify process conditions, checking especially for air in the flow tubes, tubes not filled, foreign material in the tubes, or coating in the tubes. 4. Verify that the measurement units are configured correctly for your application. 5. Purge the flow tubes.
A111	Frequency Output Fixed	<p>The frequency output has been configured to send a constant value.</p> <ol style="list-style-type: none"> 1. Stopping the totalizer will set the frequency output to zero. Cycling power to the transmitter or restarting the totalizer will restore the frequency output to normal operation. 2. Check whether the output is in loop test mode. If it is, unfix the output. 3. Check whether the output has been set to a constant value via digital communication.
A112	Upgrade Transmitter Software	Contact Micro Motion.
A113	mA Output 2 Saturated	<ol style="list-style-type: none"> 1. Check your process conditions against the values reported by the flowmeter. 2. Verify process conditions, checking especially for air in the flow tubes, tubes not filled, foreign material in the tubes, or coating in the tubes. 3. Verify that the measurement units are configured correctly for your application. 4. Purge the flow tubes. 5. Check the Upper Range Value and Lower Range Value parameters. Are they set correctly?
A114	mA Output 2 Fixed	<ol style="list-style-type: none"> 1. Check whether the output is in loop test mode. If it is, unfix the output. 2. Exit mA output trim, if applicable. 3. Check whether the output has been set to a constant value via digital communication.
A115	No External Input or Polled Data	<p>The HART polling connection to an external device has failed. No response received from polled device.</p> <ol style="list-style-type: none"> 1. Verify the external device operation. 2. Verify the wiring between the transmitter and the external device. 3. Verify the HART polling configuration.
A116	Temperature Overrange (Petroleum)	<ol style="list-style-type: none"> 1. Check your process conditions against the values reported by the flowmeter. 2. Verify the configuration of the petroleum measurement table type and temperature.

Table 12-2: Status alarms and recommended actions (continued)

Alarm code	Description	Recommended actions
A117	Density Overrange (Petroleum)	<ol style="list-style-type: none"> 1. Check your process conditions against the values reported by the flowmeter. 2. Verify the configuration of the petroleum measurement table type and density.
A118	Discrete Output 1 Fixed	The discrete output has been configured to send a constant value.
A120	Curve Fit Failure (Concentration)	Verify the configuration of the concentration measurement application.
A121	Extrapolation Alarm (Concentration)	<p>If the product in the sensor has temperature or density properties that are outside the parameters established by the concentration measurement curve, this is a symptom and no action is required. This alarm should clear when the process fluid returns to normal.</p> <p>If the problem persists, check the configuration of the concentration measurement application.</p>
A131	Meter Verification in Progress: Outputs to Last Measured Value	Meter verification in progress, with outputs set to Last Measured Value.
A132	Sensor Simulation Active	Simulation mode is enabled.
A133	EEPROM Error (Display)	Change the display module. If the problem persists, contact Micro Motion.
A141	DDC trigger(s) have completed	No action required.
N/A	Density FD Calibration in Progress	No action required.
N/A	Density D1 Calibration in Progress	No action required.
N/A	Density D2 Calibration in Progress	No action required.
N/A	Density D3 Calibration in Progress	No action required.
N/A	Density D4 Calibration in Progress	No action required.
N/A	Zero Calibration in Progress	No action required.
N/A	Reverse Flow	No action required.

12.3 Flow measurement problems

Table 12-3: Flow measurement problems and recommended actions

Problem	Possible causes	Recommended actions
Flow indication at no flow conditions or zero offset	<ul style="list-style-type: none"> • Misaligned piping (especially in new installations) • Open or leaking valve • Incorrect sensor zero 	<ul style="list-style-type: none"> • Verify that all of the characterization parameters match the data on the sensor tag. • If the flow reading is not excessively high, review the live zero. You may need to restore the factory zero. • Check for open or leaking valves or seals. • Check for mounting stress on the sensor (e.g., sensor being used to support piping, misaligned piping). • Contact Micro Motion.
Erratic non-zero flow rate under no-flow conditions	<ul style="list-style-type: none"> • Leaking valve or seal • Slug flow • Plugged or coated flow tube • Incorrect sensor orientation • Wiring problem • Vibration in pipeline at rate close to sensor tube frequency • Damping value too low • Mounting stress on sensor 	<ul style="list-style-type: none"> • Verify that the sensor orientation is appropriate for your application (refer to the sensor installation manual). • Check the drive gain and the pickoff voltage. See Section 12.26 and Section 12.27. • If the wiring between the sensor and the transmitter includes a 9-wire segment, verify that the 9-wire cable shields are correctly grounded. • Check the wiring between the sensor and transmitter. See Section 12.10. • For sensors with a junction box, check for moisture in the junction box. • Purge the flow tubes. • Check for open or leaking valves or seals. • Check for sources of vibration. • Verify damping configuration. • Verify that the measurement units are configured correctly for your application. • Check for slug flow. See Section 12.25. • Check for radio frequency interference. See Section 12.13. • Contact Micro Motion.

Table 12-3: Flow measurement problems and recommended actions (continued)

Problem	Possible causes	Recommended actions
Erratic non-zero flow rate when flow is steady	<ul style="list-style-type: none"> • Slug flow • Damping value too low • Plugged or coated flow tube • Output wiring problem • Problem with receiving device • Wiring problem 	<ul style="list-style-type: none"> • Verify that the sensor orientation is appropriate for your application (refer to the sensor installation manual). • Check the drive gain and the pickoff voltage. See Section 12.26 and Section 12.27. • If the wiring between the sensor and the transmitter includes a 9-wire segment, verify that the 9-wire cable shields are correctly grounded. • Check for air entrainment, tube fouling, flashing, or tube damage. • Check the wiring between the sensor and transmitter. See Section 12.10. • For sensors with a junction box, check for moisture in the junction box. • Purge the flow tubes. • Check for open or leaking valves or seals. • Check for sources of vibration. • Verify damping configuration. • Verify that the measurement units are configured correctly for your application. • Check for slug flow. See Section 12.25. • Check for radio frequency interference. See Section 12.13. • Contact Micro Motion.
Inaccurate flow rate or batch total	<ul style="list-style-type: none"> • Wiring problem • Inappropriate measurement unit • Incorrect flow calibration factor • Incorrect meter factor • Incorrect density calibration factors • Incorrect flowmeter grounding • Slug flow • Problem with receiving device 	<ul style="list-style-type: none"> • Check the wiring between the sensor and transmitter. See Section 12.10. • Verify that the measurement units are configured correctly for your application. • Verify that all of the characterization parameters match the data on the sensor tag. • Perform a bucket test to verify batch totals. • Zero the meter. • Check grounding. See Section 12.11. • Check for slug flow. See Section 12.25. • Verify that the receiving device, and the wiring between the transmitter and the receiving device. • Check sensor coil resistance and for shorts to case. See Section 12.28.1. • Replace the core processor or transmitter.

12.4 Density measurement problems

Table 12-4: Density measurement problems and recommended actions

Problem	Possible causes	Recommended actions
Inaccurate density reading	<ul style="list-style-type: none"> • Problem with process fluid • Incorrect density calibration factors • Wiring problem • Incorrect flowmeter grounding • Slug flow • Plugged or coated flow tube • Incorrect sensor orientation • RTD failure • Physical characteristics of sensor have changed 	<ul style="list-style-type: none"> • Check the wiring between the sensor and transmitter. See Section 12.10. • Check grounding. See Section 12.11. • Check your process conditions against the values reported by the flowmeter. • Verify that all of the characterization parameters match the data on the sensor tag. • Check for slug flow. See Section 12.25. • If two sensors with similar frequency are too near each other, separate them. • Purge the flow tubes.
Unusually high density reading	<ul style="list-style-type: none"> • Plugged or coated flow tube • Incorrect K2 value • Incorrect temperature measurement • RTD problem • In high frequency meters, this can be an indication of erosion or corrosion • In low frequency meters this can indicate tube fouling 	<ul style="list-style-type: none"> • Verify that all of the characterization parameters match the data on the sensor tag. • Purge the flow tubes. • Check for coating in the flow tubes.
Unusually low density reading	<ul style="list-style-type: none"> • Slug flow • Incorrect K2 value • In low frequency meters this can indicate erosion or corrosion 	<ul style="list-style-type: none"> • Check your process conditions against the values reported by the flowmeter. • Verify that all of the characterization parameters match the data on the sensor tag. • Check the wiring between the sensor and transmitter. See Section 12.10. • Check for tube erosion, especially if the process fluid is abrasive.

12.5 Temperature measurement problems

Table 12-5: Temperature measurement problems and recommended actions

Problem	Possible causes	Recommended actions
Temperature reading significantly different from process temperature	<ul style="list-style-type: none"> • RTD failure • Wiring problem 	<ul style="list-style-type: none"> • Check junction box for moisture or verdigris. • Perform RTD resistance checks and check for shorts to case (see Section 12.28.1). • Confirm the temperature calibration factor matches the value on the sensor tag. • Refer to status alarms (especially RTD failure alarms). • Disable external temperature compensation. • Verify temperature calibration. • Check the wiring between the sensor and transmitter. See Section 12.10.
Temperature reading slightly different from process temperature	<ul style="list-style-type: none"> • Sensor temperature not yet equalized • Sensor leaking heat 	<ul style="list-style-type: none"> • The RTD has a specification of ± 1 °C. If the error is within this range there is no problem. If the temperature measurement is outside the specification for the sensor, contact Micro Motion. • The temperature of the fluid may be changing rapidly. Allow sufficient time for the sensor to equalize with the process fluid. • Insulate the sensor if necessary. • Perform RTD resistance checks and check for shorts to case (see Section 12.28.1). • The RTD may not be making good contact with the sensor. The sensor may need to be replaced.

12.6 Milliamp output problems

Table 12-6: Milliamp output problems and recommended actions

Problem	Possible causes	Recommended actions
No mA output	<ul style="list-style-type: none"> • Wiring problem • Circuit failure • Channel not configured for desired output 	<ul style="list-style-type: none"> • Check the power supply and power supply wiring. See Section 12.9. • Check the mA output wiring. • Check the Fault Action settings. See Section 12.19. • Measure DC voltage across output terminals to verify that the output is active. • Contact Micro Motion.
Loop test failed	<ul style="list-style-type: none"> • Power supply problem • Wiring problem • Circuit failure • Channel not configured for desired output • Incorrect internal/external power configuration 	<ul style="list-style-type: none"> • Check the power supply and power supply wiring. See Section 12.9. • Check the mA output wiring. • Check the Fault Action settings. See Section 12.19. • Contact Micro Motion.
mA output below 4 mA	<ul style="list-style-type: none"> • Open in wiring • Bad output circuit • Process condition below LRV • LRV and URV are not set correctly • Fault condition if fault action is set to internal zero or downscale • Bad mA receiving device 	<ul style="list-style-type: none"> • Check your process conditions against the values reported by the flowmeter. • Verify that the receiving device, and the wiring between the transmitter and the receiving device. • Check the settings of Upper Range Value and Lower Range Value. See Section 12.18. • Check the Fault Action settings. See Section 12.19.
Constant mA output	<ul style="list-style-type: none"> • Incorrect process variable assigned to the output • Fault condition exists • Non-zero HART address (mA output 1) • Output is configured for loop test mode • Zero calibration failure 	<ul style="list-style-type: none"> • Verify the output variable assignments. • View and resolve any existing alarm conditions. • Check the HART address and Loop Current Mode. See Section 12.15. • Check to see if a loop test is in process (the output is fixed). • Check HART burst mode configuration. See Section 12.16. • If related to a zero calibration failure, cycle power to the meter and retry the zeroing procedure.

Table 12-6: Milliamp output problems and recommended actions (continued)

Problem	Possible causes	Recommended actions
mA output consistently out of range	<ul style="list-style-type: none"> • Incorrect process variable or units assigned to output • Fault condition if fault action is set to up-scale or downscale • LRV and URV are not set correctly 	<ul style="list-style-type: none"> • Verify the output variable assignments. • Verify the measurement units configured for the output. • Check the Fault Action settings. See Section 12.19. • Check the settings of Upper Range Value and Lower Range Value. See Section 12.18. • Check the mA output trim. See Section 12.17.
Consistently incorrect mA measurement	<ul style="list-style-type: none"> • Loop problem • Output not trimmed correctly • Incorrect flow measurement unit configured • Incorrect process variable configured • LRV and URV are not set correctly 	<ul style="list-style-type: none"> • Check the mA output trim. See Section 12.17. • Verify that the measurement units are configured correctly for your application. • Verify the process variable assigned to the mA output. • Check the settings of Upper Range Value and Lower Range Value. See Section 12.18.
mA output correct at lower current, but incorrect at higher current	<ul style="list-style-type: none"> • mA loop resistance may be set too high 	<ul style="list-style-type: none"> • Verify that the mA output load resistance is below maximum supported load (see the installation manual for your transmitter).

12.7 Frequency output problems

Table 12-7: Frequency output problems and recommended actions

Problem	Possible causes	Recommended actions
No frequency output	<ul style="list-style-type: none"> • Stopped totalizer • Process condition below cutoff • Fault condition if fault action is set to internal zero or downscale • Slug flow • Flow in reverse direction from configured flow direction parameter • Bad frequency receiving device • Output level not compatible with receiving device • Bad output circuit • Incorrect internal/external power configuration • Incorrect pulse width configuration • Output not powered • Wiring problem 	<ul style="list-style-type: none"> • Verify that the process conditions are below the low-flow cutoff. Reconfigure the low-flow cutoff if necessary. • Check the Fault Action settings. See Section 12.19. • Verify that the totalizers are not stopped. A stopped totalizer will cause the frequency output to be locked. • Check for slug flow. See Section 12.25. • Check flow direction. See Section 12.23. • Verify that the receiving device, and the wiring between the transmitter and the receiving device. • Verify that the channel is wired and configured as a frequency output. • Verify the power configuration for the frequency output (internal vs. external). • Check the pulse width. See Section 12.20. • Perform a loop test. See Section 12.12.
Consistently incorrect frequency measurement	<ul style="list-style-type: none"> • Output not scaled correctly • Incorrect flow measurement unit configuration 	<ul style="list-style-type: none"> • Check the frequency output scaling. See Section 12.21. • Verify that the measurement units are configured correctly for your application.
Erratic frequency output	<ul style="list-style-type: none"> • Radio frequency interference (RFI) from environment 	<ul style="list-style-type: none"> • Check for radio frequency interference. See Section 12.13.

12.8 Use sensor simulation for troubleshooting

When sensor simulation is enabled, the transmitter reports user-specified values for mass flow, temperature, and density. This allows you to reproduce various process conditions or to test the system.

You can use sensor simulation to help distinguish between legitimate process noise and externally caused variation. For example, consider a receiving device that reports an unexpectedly erratic flow value. If sensor simulation is enabled and the observed flow rate does not match the simulated value, the source of the problem is likely to be somewhere between the transmitter and the receiving device.

Important

When sensor simulation is active, the simulated value is used in all transmitter outputs and calculations, including totals and inventories, volume flow calculations, and concentration calculations. Disable all automatic functions related to the transmitter outputs and place the loop in manual operation. Do not enable simulation mode unless your application can tolerate these effects, and be sure to disable simulation mode when you have finished testing.

For more information on using sensor simulation using ProLink II, see [Section 7.1](#).

12.9 Check power supply wiring

If the power supply wiring is damaged or improperly connected, the transmitter may not receive enough power to operate properly.

Prerequisites

You will need the installation manual for your transmitter.

Procedure

1. Before inspecting the power supply wiring, disconnect the power source.

CAUTION!

If the transmitter is in a hazardous area, wait five minutes after disconnecting the power.

2. Verify that the correct external fuse is used.
An incorrect fuse can limit current to the transmitter and keep it from initializing.
3. Ensure that the power supply wires are connected to the correct terminals.
4. Verify that the power supply wires are making good contact, and are not clamped to the wire insulation.
5. Inspect the voltage label on the inside of the field-wiring compartment.

The voltage supplied to the transmitter should match the voltage specified on the label.

6. Reapply power to the transmitter.

CAUTION!

If the transmitter is in a hazardous area, do not reapply power to the transmitter with the housing cover removed. Reapplying power to the transmitter while the housing cover is removed could cause an explosion.

7. Use a voltmeter to test the voltage at the transmitter's power supply terminals.

The voltage should be within specified limits. For DC power, you may need to size the cable.

12.10 Check sensor-to-transmitter wiring

A number of power-supply and output problems may occur if the wiring between the sensor and the transmitter is improperly connected, or if the wiring becomes damaged.

Prerequisites

You will need the installation manual for your transmitter.

Procedure

1. Before opening the wiring compartments, disconnect the power source.

⚠ CAUTION!

If the transmitter is in a hazardous area, wait five minutes after disconnecting the power.

2. Verify that the transmitter is connected to the sensor according to the information provided in your transmitter installation manual.
3. Verify that the wires are making good contact with the terminals.
4. Check the continuity of all wires from the transmitter to the sensor.

12.11 Check grounding

The sensor and the transmitter must be grounded. If the core processor is installed as part of the transmitter or the sensor, it is grounded automatically. If the core processor is installed separately, it must be grounded separately.

Prerequisites

You will need:

- Installation manual for your sensor
- Installation manual for your transmitter

Procedure

Refer to the sensor and transmitter installation manuals for grounding requirements and instructions.

12.12 Perform loop tests

A loop test is a way to verify that the transmitter and the remote device are communicating properly. A loop test also helps you know whether you need to trim mA outputs.

12.12.1 Perform loop tests using the display

Prerequisites

Before performing a loop test, configure the channels for the transmitter inputs and outputs that will be used in your application.

Follow appropriate procedures to ensure that loop testing will not interfere with existing measurement and control loops.

Procedure

1. Test the mA output(s).
 - a. Choose and select a low value, e.g., 4 mA.

Dots traverse the display while the output is fixed.
 - b. Read the mA current at the receiving device and compare it to the transmitter output.

The readings do not need to match exactly. If the values are slightly different, you can correct the discrepancy by trimming the output.
 - c. At the transmitter, activate Select.
 - d. Scroll to and select a high value, e.g., 20 mA.

Dots traverse the display while the output is fixed.
 - e. Read the mA current at the receiving device and compare it to the transmitter output.

The readings do not need to match exactly. If the values are slightly different, you can correct the discrepancy by trimming the output.
 - f. At the transmitter, activate Select.
2. Test the frequency output(s).
 - a. Choose OFFLINE MAINT > SIM > FO SIM, and select the frequency output value.

The frequency output can be set to 1, 10, or 15 kHz.

Note
If the Weights & Measures application is enabled on the transmitter, it is not possible to perform a loop test of the frequency output, even when the transmitter is unsecured.

Dots traverse the display while the output is fixed.

 - b. Read the frequency signal at the receiving device and compare it to the transmitter output.
 - c. At the transmitter, activate Select.
3. Test the discrete output(s).
 - a. Choose OFFLINE MAINT > SIM > DO SIM, and select SET ON.

Dots traverse the display while the output is fixed.
 - b. Verify the signal at the receiving device.

- c. At the transmitter, activate Select.
- d. Scroll to and select SET OFF.
- e. Verify the signal at the receiving device.
- f. At the transmitter, activate Select.

Postrequisites

- If the mA output reading was slightly off at the receiving device, you can correct this discrepancy by trimming the output.
- If the mA output reading was significantly off (± 200 microamps), or if at any step the reading was faulty, verify the wiring between the transmitter and the remote device, and try again.
- If the discrete output reading is reversed, check the setting of Discrete Output Polarity.

12.12.2 Perform loop tests using ProLink II

Prerequisites

Before performing a loop test, configure the channels for the transmitter inputs and outputs that will be used in your application.

Follow appropriate procedures to ensure that loop testing will not interfere with existing measurement and control loops.

ProLink II must be running and must be connected to the transmitter.

Procedure

1. Test the mA output(s).
 - a. Choose ProLink > Test > Fix Milliamp 1 or ProLink > Test > Fix Milliamp 2.
 - b. Enter 4 mA in Set Output To.
 - c. Click Fix mA.
 - d. Read the mA current at the receiving device and compare it to the transmitter output.

The readings do not need to match exactly. If the values are slightly different, you can correct the discrepancy by trimming the output.
 - e. Click UnFix mA.
 - f. Enter 20 mA in Set Output To.
 - g. Click Fix mA.
 - h. Read the mA current at the receiving device and compare it to the transmitter output.

The readings do not need to match exactly. If the values are slightly different, you can correct the discrepancy by trimming the output.

- i. Click UnFix mA.
2. Test the frequency output(s).

Note

If the Weights & Measures application is enabled on the transmitter, it is not possible to perform a loop test of the frequency output, even when the transmitter is unsecured.

- a. Choose ProLink > Test > Fix Freq Out.
- b. Enter the frequency output value in Set Output To.
- c. Click Fix Frequency.
- d. Read the frequency signal at the receiving device and compare it to the transmitter output.
- e. Click UnFix Freq.
3. Test the discrete output(s).
 - a. Choose ProLink > Test > Fix Discrete Output.
 - b. Select On.
 - c. Verify the signal at the receiving device.
 - d. Select Off.
 - e. Verify the signal at the receiving device.
 - f. Click UnFix.

Postrequisites

- If the mA output reading was slightly off at the receiving device, you can correct this discrepancy by trimming the output.
- If the mA output reading was significantly off (± 200 microamps), or if at any step the reading was faulty, verify the wiring between the transmitter and the remote device, and try again.
- If the discrete output reading is reversed, check the setting of Discrete Output Polarity.

12.12.3 Perform loop tests using ProLink III

Prerequisites

Before performing a loop test, configure the channels for the transmitter inputs and outputs that will be used in your application.

Follow appropriate procedures to ensure that loop testing will not interfere with existing measurement and control loops.

ProLink II must be running and must be connected to the transmitter.

Procedure

1. Test the mA output(s).
 - a. Choose Device Tools > Diagnostics > Testing > mA Output 1 Test or Device Tools > Diagnostics > Testing > mA Output 2 Test.
 - b. Enter 4 in Fix to:.
 - c. Click Fix mA.
 - d. Read the mA current at the receiving device and compare it to the transmitter output.

The readings do not need to match exactly. If the values are slightly different, you can correct the discrepancy by trimming the output.
 - e. Click UnFix mA.
 - f. Enter 20 in Fix to:.
 - g. Click Fix mA.
 - h. Read the mA current at the receiving device and compare it to the transmitter output.

The readings do not need to match exactly. If the values are slightly different, you can correct the discrepancy by trimming the output.
 - i. Click UnFix mA.
2. Test the frequency output(s).

Note

If the Weights & Measures application is enabled on the transmitter, it is not possible to perform a loop test of the frequency output, even when the transmitter is unsecured.

- a. Choose Device Tools > Diagnostics > Testing > Frequency Output Test.
 - b. Enter the frequency output value in Fix to.
 - c. Click Fix FO.
 - d. Read the frequency signal at the receiving device and compare it to the transmitter output.
 - e. Click UnFix FO.
3. Test the discrete output(s).
 - a. Choose Device Tools > Diagnostics > Testing > Discrete Output Test.
 - b. Set Fix To: to ON.
 - c. Verify the signal at the receiving device.
 - d. Set Fix To: to OFF.
 - e. Verify the signal at the receiving device.

- f. Click UnFix.

12.12.4 Perform loop tests using the Field Communicator

Tip

Loop tests are not required. However, Micro Motion recommends performing a loop test for every input or output available on your transmitter. The inputs and outputs available on your transmitter vary according to your purchase option and your channel configuration. You may not need to perform all of the loop tests described here.

Prerequisites

Before performing a loop test, configure the channels for the transmitter inputs and outputs that will be used in your application.

Follow appropriate procedures to ensure that loop testing will not interfere with existing measurement and control loops.

Procedure

1. Test the mA output(s).
 - a. Choose Service Tools > Simulate > Simulate Outputs > mA Output Loop Test and select 4 mA.
 - b. Read the mA current at the receiving device and compare it to the transmitter output.

The readings do not need to match exactly. If the values are slightly different, you can correct the discrepancy by trimming the output.
 - c. Press OK.
 - d. Select 20 mA.
 - e. Read the mA current at the receiving device and compare it to the transmitter output.

The readings do not need to match exactly. If the values are slightly different, you can correct the discrepancy by trimming the output.
 - f. Press OK.
 - g. Choose End.
2. Test the frequency output(s).

Note

If the Weights & Measures application is enabled on the transmitter, it is not possible to perform a loop test of the frequency output, even when the transmitter is unsecured.

- a. Press Service Tools > Simulate > Simulate Outputs > Frequency Output Test, and choose the frequency output level.

- b. Read the frequency signal at the receiving device and compare it to the transmitter output.
 - c. Choose End.
3. Test the discrete output(s).
 - a. Press Service Tools > Simulate > Simulate Outputs > Discrete Output Test.
 - b. Choose Off.
 - c. Verify the signal at the receiving device.
 - d. Press OK.
 - e. Choose On.
 - f. Verify the signal at the receiving device.
 - g. Press OK.
 - h. Choose End.

Postrequisites

- If the mA output reading was slightly off at the receiving device, you can correct this discrepancy by trimming the output.
- If the mA output reading was significantly off (± 200 microamps), or if at any step the reading was faulty, verify the wiring between the transmitter and the remote device, and try again.
- If the discrete output reading is reversed, check the setting of Discrete Output Polarity.

12.13 Check for radio frequency interference (RFI)

The transmitter's frequency output or discrete output can be affected by radio frequency interference (RFI). Possible sources of RFI include a source of radio emissions, or a large transformer, pump, or motor that can generate a strong electromagnetic field. Several methods to reduce RFI are available. Use one or more of the following suggestions, as appropriate to your installation.

Procedure

- Eliminate the RFI source.
- Move the transmitter.
- Use shielded cable for the frequency output or discrete output.
 - Terminate the shielding at the output device. If this is impossible, terminate the shielding at the cable gland or conduit fitting.
 - Do not terminate the shielding inside the wiring compartment.
 - 360-degree termination of shielding is unnecessary.

12.14 Check the HART communication loop

If you cannot establish or maintain HART communications, the HART loop may be wired incorrectly.

Prerequisites

You will need:

- A copy of your transmitter installation manual
- A Field Communicator
- Optional: the *HART Application Guide*, available at www.hartcomm.org

Procedure

1. Verify that the loop wires are connected as shown in the wiring diagrams in the transmitter installation manual.

If your HART network is more complex than the wiring diagrams in the transmitter installation manual, contact either Micro Motion or the HART Communication Foundation.

2. Disconnect the primary mA output wiring from the transmitter.
3. Install a 250–1000 Ω resistor across the transmitter's primary mA output terminals.
4. Check the voltage drop across the resistor (4–20 mA = 1–5 VDC).

If voltage drop is less than 1 VDC, add resistance to achieve a voltage drop of greater than 1 VDC.

5. Connect a Field Communicator directly across the resistor and attempt to communicate (poll).

If communication with the transmitter cannot be established, the transmitter may need service. Contact Micro Motion.

12.15 Check HART Address and Loop Current Mode

If the transmitter is producing a fixed current from the mA output, the Loop Current Mode parameter may be disabled.

When Loop Current Mode is disabled, the mA output produces a fixed value, and does not report process data or implement its fault action.

When HART Address is changed, some configuration tools will automatically change Loop Current Mode.

Tip

Always verify Loop Current Mode after setting or changing HART Address.

Procedure

1. Set HART Address as appropriate for your HART network.
The default address is 0. This is the recommended value unless the transmitter is in a multidrop network.
2. Set Loop Current Mode to Enabled.

12.16 Check HART burst mode

HART burst mode can cause the transmitter to output unexpected values. Burst mode is normally disabled, and should only be enabled if another device on the HART network requires burst mode communication.

1. Check to see if burst mode is enabled or disabled.
2. If burst mode is enabled, disable it.

12.17 Check the trimming of the mA output

If the trim values for the mA output are inaccurate, the transmitter will under-compensate or over-compensate the output.

1. Trim the output, following the standard procedure.
2. If this does not correct the problem, contact Micro Motion.

12.18 Check Lower Range Value and Upper Range Value

If the process conditions fall below the configured Lower Range Value (LRV) or rise above the configured Upper Range Value (URV), the transmitter outputs may send unexpected values.

1. Make a note of your current process conditions.
2. Check the configuration of the LRV and URV.

12.19 Check mA Output Fault Action

mA Output Fault Action controls the behavior of the mA output if the transmitter encounters an internal fault condition. If the mA output is reporting a constant value below 4 mA or above 20 mA, the transmitter may be in a fault condition.

1. Check the status alarms for active fault conditions.
2. If there are active fault conditions, the transmitter is performing correctly. If you want to change its behavior, consider the following options:
 - Change the setting of mA Output Fault Action.

- For the relevant status alarms, change the setting of Alarm Severity to Ignore.
3. If there are no active fault conditions, continue troubleshooting.

12.20 Check Frequency Output Maximum Pulse Width

If Frequency Output Maximum Pulse Width is set incorrectly, the frequency output may report an incorrect value.

Verify the configuration of Frequency Output Maximum Pulse Width.

For most applications, the default value for Frequency Output Maximum Pulse Width is appropriate. This corresponds to a 50% duty cycle.

12.21 Check Frequency Output Scaling Method

If Frequency Output Scaling Method is set incorrectly, the frequency output may report an incorrect value.

1. Verify the configuration of Frequency Output Scaling Method.
2. If you changed the setting of Frequency Output Scaling Method, check the settings of all other frequency output parameters.

12.22 Check Frequency Output Fault Action

The Frequency Output Fault Action controls the behavior of the frequency output if the transmitter encounters an internal fault condition. If the frequency output is reporting a constant value, the transmitter may be in a fault condition.

1. Check the status alarms for active fault conditions.
2. If there are active fault conditions, the transmitter is performing correctly. If you want to change its behavior, consider the following options:
 - Change the setting of Frequency Output Fault Action.
 - For the relevant status alarms, change the setting of Alarm Severity to Ignore.
3. If there are no active fault conditions, continue troubleshooting.

12.23 Check Flow Direction

If Flow Direction is set inappropriately for your process, the transmitter may report unexpected flow values or totals.

The Flow Direction parameter interacts with actual flow direction to affect flow values, flow totals and inventories, and output behavior. For the simplest operation, actual process flow should match the flow arrow that is on the side of the sensor case.

Procedure

1. Verify the actual direction of process flow through the sensor.
2. Verify the configuration of Flow Direction.

12.24 Check the cutoffs

If the transmitter cutoffs are configured incorrectly, the transmitter may report zero flow when flow is present, or very small amounts of flow under no-flow conditions.

There are separate cutoff parameters for mass flow rate, volume flow rate, gas standard volume flow rate (if applicable), and density. There is an independent cutoff for each mA output on your transmitter. The interaction between cutoffs sometimes produces unexpected results.

Procedure

Verify the configuration of the cutoffs.

Tip

For typical applications, Micro Motion recommends setting Mass Flow Cutoff to the zero stability value for your sensor, multiplied by 10. Zero stability values can be found in the Product Data Sheet for your sensor.

12.25 Check for slug flow (two-phase flow)

Slug flow (two-phase flow, entrained gas) can cause spikes in the drive gain. This may cause the transmitter to report zero flow, or to post several different alarms.

1. Check for slug flow alarms.

If the transmitter is not generating slug flow alarms, slug flow is not the source of your problem.
2. Check the process for cavitation, flashing, or leaks.
3. Monitor the density of your process fluid output under normal process conditions.
4. Check the settings of Slug Low Limit, Slug High Limit, and Slug Duration.

Tip

You can reduce the occurrence of slug flow alarms by setting Slug Low Limit to a lower value, Slug High Limit to a higher value, or Slug Duration to a higher value.

12.26 Check the drive gain

Excessive or erratic drive gain may indicate any of a variety of process conditions, sensor problems, or configuration problems.

To know whether your drive gain is excessive or erratic, you must collect drive gain data during the problem condition and compare it to drive gain data from a period of normal operation.

Excessive (saturated) drive gain

Table 12-8: Possible causes and recommended actions for excessive (saturated) drive gain

Possible cause	Recommended actions
Slug flow	Check for slug flow. See Section 12.25 .
Partially filled flow tube	Correct process conditions so that the flow tubes are full.
Plugged flow tube	Check the pickoff voltages (see Section 12.27). If either of them are close to zero (but neither is zero), plugged tubes may be the source of your problem. Purge the tubes. In extreme cases, you may need to replace the sensor.
Cavitation, flashing, or air entrainment; settling of two- or three-phase fluids	<ul style="list-style-type: none"> • Increase the inlet or back pressure at the sensor. • If a pump is located upstream from the sensor, increase the distance between the pump and sensor. • The sensor may need to be reorientated. Consult the installation manual for your sensor for recommended orientations.
Drive board or module failure	Contact Micro Motion.
Bent flow tube	Check the pickoff voltages (see Section 12.27). If either of them are close to zero (but neither is zero), the flow tubes may be bent. The sensor will need to be replaced.
Cracked flow tube	Replace the sensor.
Sensor imbalance	Contact Micro Motion.
Mechanical binding at sensor	Ensure sensor is free to vibrate.
Open drive or left pickoff sensor coil	Contact Micro Motion.
Flow rate out of range	Ensure that flow rate is within sensor limits.
Incorrect sensor characterization	Verify the characterization parameters.

Erratic drive gain

Table 12-9: Possible causes and recommended actions for erratic drive gain

Possible cause	Recommended actions
Wrong K1 characterization constant for sensor	Verify the K1 characterization parameter.

Table 12-9: Possible causes and recommended actions for erratic drive gain (continued)

Possible cause	Recommended actions
Polarity of pick-off reversed or polarity of drive reversed	Contact Micro Motion.
Slug flow	Check for slug flow. See Section 12.25 .
Foreign material caught in flow tubes	<ul style="list-style-type: none"> Purge the flow tubes. Replace the sensor.

12.26.1 Collect drive gain data

Drive gain data can be used to diagnose a variety of process and equipment conditions. Collect drive gain data from a period of normal operation, and use this data as a baseline for troubleshooting.

Procedure

1. Navigate to the drive gain data.
2. Observe and record drive gain data over an appropriate period of time, under a variety of process conditions.

12.27 Check the pickoff voltage

If the pickoff voltage readings are unusually low, you may have any of a variety of process or equipment problems.

To know whether your pickoff voltage is unusually low, you must collect pickoff voltage data during the problem condition and compare it to pickoff voltage data from a period of normal operation.

Table 12-10: Possible causes and recommended actions for low pickoff voltage

Possible cause	Recommended actions
Air entrainment	<ul style="list-style-type: none"> Increase the inlet or back pressure at the sensor. If a pump is located upstream from the sensor, increase the distance between the pump and sensor. The sensor may need to be reoriented. Consult the installation manual for your sensor for recommended orientations.
Faulty wiring runs between the sensor and transmitter	Verify wiring between sensor and transmitter.
Process flow rate beyond the limits of the sensor	Verify that the process flow rate is not out of range of the sensor.
Slug flow	Check for slug flow. See Section 12.25 .

Table 12-10: Possible causes and recommended actions for low pickoff voltage (continued)

Possible cause	Recommended actions
No tube vibration in sensor	<ul style="list-style-type: none"> • Check for plugging. • Ensure sensor is free to vibrate (no mechanical binding). • Verify wiring. • Test coils at sensor. See Section 12.28.1.
Moisture in the sensor electronics	Eliminate the moisture in the sensor electronics.
The sensor is damaged, or sensor magnets may have become demagnetized	Replace the sensor.

12.27.1 Collect pickoff voltage data

Pickoff voltage data can be used to diagnose a variety of process and equipment conditions. Collect pickoff voltage data from a period of normal operation, and use this data as a baseline for troubleshooting.

Procedure

1. Navigate to the pickoff voltage data.
2. Observe and record data for both the left pickoff and the right pickoff, over an appropriate period of time, under a variety of process conditions.

12.28 Check for electrical shorts

Shorts between sensor terminals or between the sensor terminals and the sensor case can cause the sensor to stop working.

Table 12-11: Possible causes and recommended actions for electrical shorts

Possible cause	Recommended action
Moisture inside the junction box	Ensure that the junction box is dry and no corrosion is present.
Liquid or moisture inside the sensor case	Contact Micro Motion.
Internally shorted feedthrough	Contact Micro Motion.
Faulty cable	Replace the cable.
Improper wire termination	Verify wire terminations inside sensor junction box. The Micro Motion document titled <i>9-Wire Flowmeter Cable Preparation and Installation Guide</i> may offer some assistance.

12.28.1 Check the sensor coils

Checking the sensor coils can identify electrical shorts.

Restriction

This procedure applies only to 9-wire remote-mount transmitters and remote transmitters with remote core processors..

Procedure

1. Disconnect power to the transmitter.

⚠ CAUTION!

If the transmitter is in a hazardous area, wait 5 minutes before continuing.

2. Remove the end-cap from the core processor housing.
3. Unplug the terminal blocks from the terminal board on the core processor.
4. Using a digital multimeter (DMM), check the pickoff coils by placing the DMM leads on the unplugged terminal blocks for each terminal pair. See [Table 12-12](#) for a list of the coils. Record the values.

Table 12-12: Coils and test terminal pairs

Coil	Sensor model	Terminal colors
Drive coil	All	Brown to red
Left pickoff coil (LPO)	All	Green to white
Right pickoff coil (RPO)	All	Blue to gray
Resistance temperature detector (RTD)	All	Yellow to violet
Lead length compensator (LLC)	All except T-Series and CMF400 (see note)	Yellow to orange
Composite RTD	T-Series	Yellow to orange
Fixed resistor (see note)	CMF400	Yellow to orange

Note

The CMF400 fixed resistor applies only to certain specific CMF400 releases. Contact Micro Motion for more information.

There should be no open circuits, that is, no infinite resistance readings. The left pickoff and right pickoff readings should be the same or very close ($\pm 5 \Omega$). If there are any unusual readings, repeat the coil resistance tests at the sensor junction box to eliminate the possibility of faulty cable. The readings for each coil pair should match at both ends.

5. Test the terminals in the sensor junction box for shorts to case.

- a. Leave the terminal blocks disconnected.
- b. Remove the lid of the junction box.
- c. Testing one terminal at a time, place a DMM lead on the terminal and the other lead on the sensor case.

With the DMM set to its highest range, there should be infinite resistance on each lead. If there is any resistance at all, there is a short to case.

6. Test the resistance of junction box terminal pairs.
 - a. Test the brown terminal against all other terminals except the red one.
 - b. Test the red terminal against all other terminals except the brown one.
 - c. Test the green terminal against all other terminals except the white one.
 - d. Test the white terminal against all other terminals except the green one.
 - e. Test the blue terminal against all other terminals except the gray one.
 - f. Test the gray terminal against all other terminals except the blue one.
 - g. Test the orange terminal against all other terminals except the yellow and violet ones.
 - h. Test the yellow terminal against all other terminals except the orange and violet ones.
 - i. Test the violet terminal against all other terminals except the yellow and orange ones.

There should be infinite resistance for each pair. If there is any resistance at all, there is a short between terminals.

Postrequisites

To return to normal operation:

1. Plug the terminal blocks into the terminal board.
2. Replace the end-cap on the core processor housing.
3. Replace the lid on the sensor junction box.

Important

When reassembling the meter components, be sure to grease all O-rings.

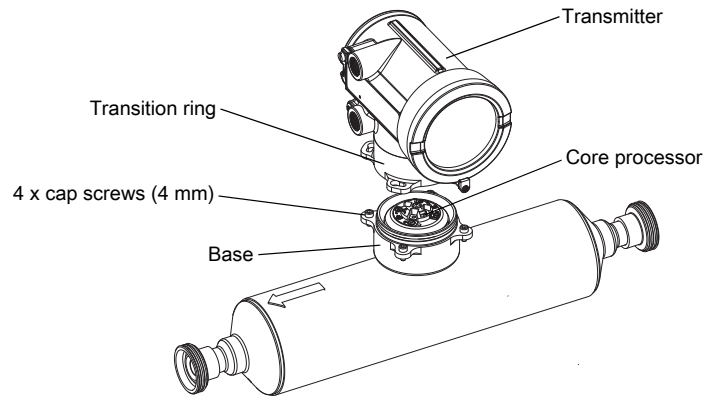
12.29 Check the core processor LED

The core processor has an LED that indicates different meter conditions.

1. Maintain power to the transmitter.
2. If you have a 4-wire remote installation or a remote core processor with remote transmitter installation:

- a. Remove the core processor lid. The core processor is intrinsically safe and can be opened in all environments.
- b. Check the state of the core processor LED.
3. If you have an integral installation:
 - a. Loosen the four cap screws that fasten the transmitter to the base.

Figure 12-1: Integral installation components

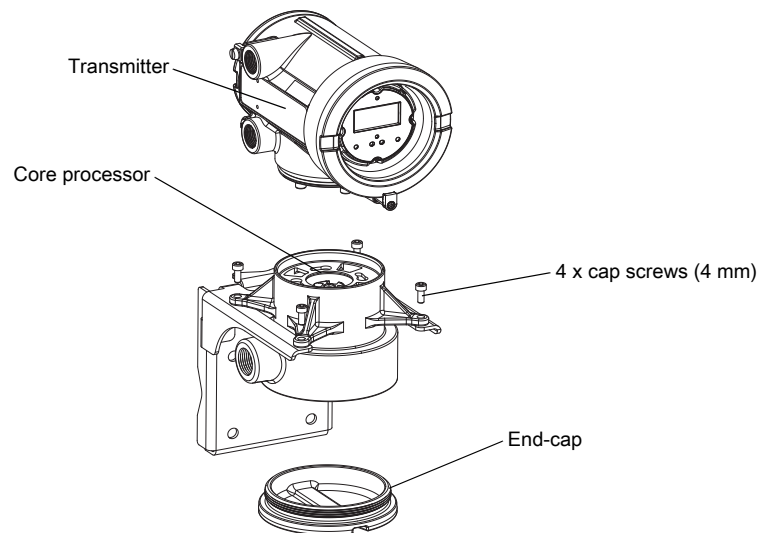


-
- b. Rotate the transmitter counter-clockwise so that the cap screws are in the unlocked position.
 - c. Gently lift the transmitter straight up, disengaging it from the cap screws.

Important

Do not disconnect or damage the wires that connect the transmitter to the core processor.

- d. Check the state of the core processor LED.
4. If you have a 9-wire remote installation:
 - a. Remove the end-cap.

Figure 12-2: 9-wire remote installation components

- b. Inside the core processor housing, loosen the three screws that hold the core processor mounting plate in place.
 - Do not remove the screws.
- c. Rotate the mounting plate so that the screws are in the unlocked position.
- d. Holding the tab on the mounting plate, slowly lower the mounting plate so that the top of the core processor is visible.

Important

Do not disconnect or damage the wires that connect the transmitter to the core processor.

- e. Check the state of the core processor LED.

Postrequisites

To return to normal operation:

- For a 4-wire remote installation or a remote core processor with remote transmitter installation, replace the core processor lid.
- For an integral installation:
 1. Without pinching or stretching the wires, lower the transmitter onto the base, inserting the cap screws into the slots.
 2. Rotate the transmitter clockwise so that the cap screws are in the locked position.
 3. Tighten the cap screws, torquing to 20 to 30 in-lbs (2.3 to 3.4 N-m).
- For a 9-wire remote installation:
 1. Without pinching or stressing the wires, slide the mounting plate into place.
 2. Rotate the mounting plate so that the screws are in the locked position.

3. Tighten the screws, torquing to 6 to 8 in-lbs (0.7 to 0.9 N-m).
4. Replace the end-cap.

Important

When reassembling the meter components, be sure to grease all O-rings.

12.29.1 Core processor LED states

Table 12-13: Standard core processor LED states

LED state	Description	Recommended actions
1 flash per second (ON 25%, OFF 75%)	Normal operation	No action required.
1 flash per second (ON 75%, OFF 25%)	Slug flow (two-phase flow)	See Section 12.25 .
Solid ON	Zero or calibration in progress	No action required.
	Core processor receiving between 11.5 and 5 volts	Check power supply to transmitter.
3 rapid flashes, followed by pause	Sensor not recognized	Check wiring between transmitter and sensor.
	Improper configuration	Check sensor characterization parameters.
	Broken pin between sensor and core processor	The meter requires factory service.
4 flashes per second	Fault condition	Check alarm status.
OFF	Core processor receiving less than 5 volts	<ul style="list-style-type: none"> • Verify power supply wiring to core processor. • If transmitter status LED is lit, transmitter is receiving power. Check voltage across terminals 1 (VDC+) and 2 (VDC-) in core processor. If reading is less than 1 VDC, verify power supply wiring to core processor. Wires may be switched. • If transmitter status LED is not lit, transmitter is not receiving power. Check power supply. If power supply is operational, internal transmitter, display, or LED failure is possible – the meter may require factory service.
	Core processor internal failure	The meter requires factory service.

Table 12-14: Enhanced core processor LED states

LED state	Description	Recommended action
Solid green	Normal operation	No action required.
Flashing yellow	Zero in progress	No action required.
Solid yellow	Low-severity alarm	Check alarm status.

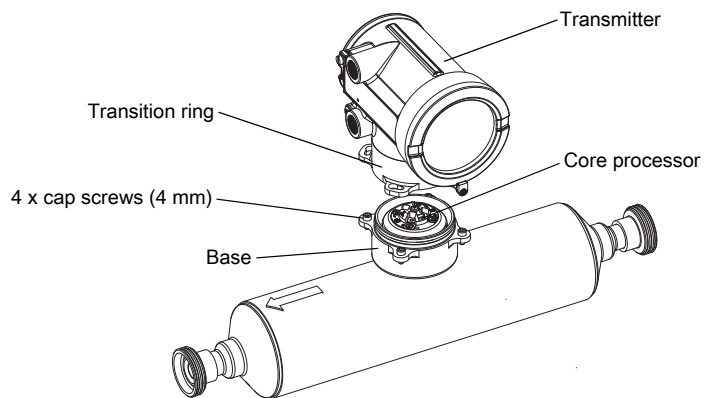
Table 12-14: Enhanced core processor LED states (continued)

LED state	Description	Recommended action
Solid red	High-severity alarm	Check alarm status.
Flashing red (80% on, 20% off)	Tubes not full	<ul style="list-style-type: none"> If alarm A105 (slug flow) is active, refer to the recommended actions for that alarm. If alarm A033 (tubes not full) is active, verify process. Check for air in the flow tubes, tubes not filled, foreign material in tubes, or coating in tubes.
Flashing red (50% on, 50% off)	Electronics failed	The meter requires factory service.
Flashing red (50% on, 50% off, skips every 4th)	Sensor failed	The meter requires factory service.
OFF	Core processor receiving less than 5 volts	<ul style="list-style-type: none"> Verify power supply wiring to core processor. If transmitter status LED is lit, transmitter is receiving power. Check voltage across terminals 1 (VDC+) and 2 (VDC-) in core processor. If reading is less than 1 VDC, verify power supply wiring to core processor. Wires may be switched. If transmitter status LED is not lit, transmitter is not receiving power. Check power supply. If power supply is operational, internal transmitter, display, or LED failure is possible – the meter may require factory service.
	Core processor internal failure	The meter requires factory service.

12.30 Perform a core processor resistance test

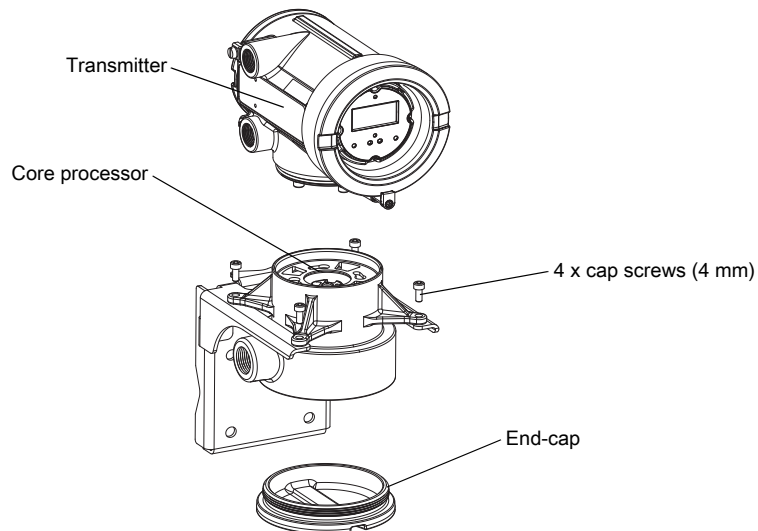
1. Power down the transmitter.
2. If you have a 4-wire remote installation or a remote core processor with remote transmitter installation, remove the core processor lid.
3. If you have an integral installation:
 - a. Loosen the four cap screws that fasten the transmitter to the base.

Figure 12-3: Integral installation components



- b. Rotate the transmitter counter-clockwise so that the cap screws are in the unlocked position.
 - c. Gently lift the transmitter straight up, disengaging it from the cap screws.
4. If you have a 9-wire remote installation:
- a. Remove the end-cap.

Figure 12-4: 9-wire remote installation components



- b. Inside the core processor housing, loosen the three screws that hold the core processor mounting plate in place.
Do not remove the screws.
- c. Rotate the mounting plate so that the screws are in the unlocked position.
- d. Holding the tab on the mounting plate, slowly lower the mounting plate so that the top of the core processor is visible.

5. At the core processor, disconnect the 4-wire cable between the core processor and the transmitter.
6. Measure the resistance between core processor terminal pairs 3–4, 2–3, and 2–4.

Terminal pair	Function	Expected resistance
3–4	RS-485/A and RS-485/B	40 kΩ to 50 kΩ
2–3	VDC– and RS-485/A	20 kΩ to 25 kΩ
2–4	VDC– and RS-485/B	20 kΩ to 25 kΩ

7. If any resistance measurements are lower than specified, the core processor may not be able to communicate with a transmitter or a remote host. The meter may need factory service.

Postrequisites

To return to normal operation:

- For a 4-wire remote installation or a remote core processor with remote transmitter installation:
 1. Reconnect the 4-wire cable between the core processor and the transmitter.
 2. Replace the core processor lid.
 3. Restore power to the transmitter.
- For an integral installation:
 1. Reconnect the 4-wire cable between the core processor and the transmitter.
 2. Without pinching or stretching the wires, lower the transmitter onto the base, inserting the cap screws into the slots.
 3. Rotate the transmitter clockwise so that the cap screws are in the locked position.
 4. Tighten the cap screws, torquing to 20 to 30 in-lbs (2.3 to 3.4 N-m).
 5. Restore power to the transmitter.
- For a 9-wire remote installation:
 1. Reconnect the 4-wire cable between the core processor and the transmitter.
 2. Without pinching or stressing the wires, slide the mounting plate into place.
 3. Rotate the mounting plate so that the screws are in the locked position.
 4. Tighten the screws, torquing to 6 to 8 in-lbs (0.7 to 0.9 N-m).
 5. Replace the end-cap.
 6. Restore power to the transmitter.

Important

When reassembling the meter components, be sure to grease all O-rings.

Appendix A

Using the transmitter display

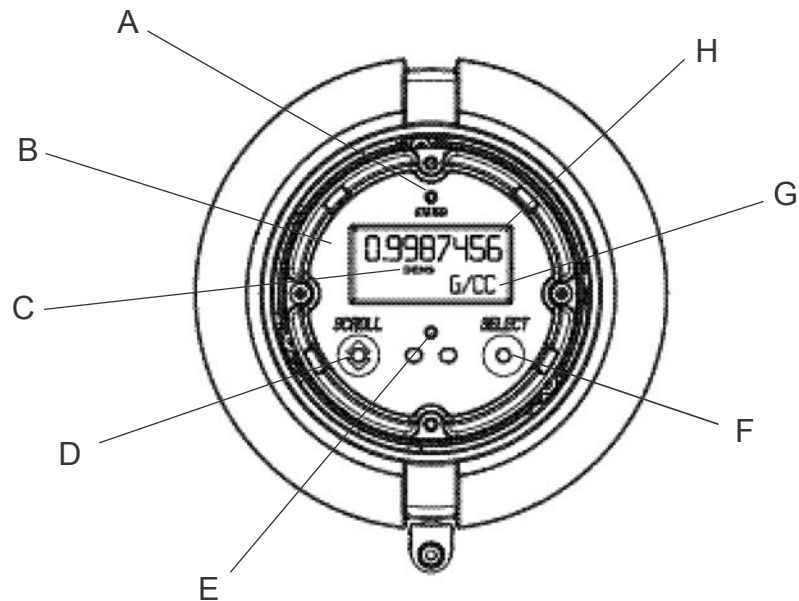
Topics covered in this appendix:

- *Components of the transmitter interface*
- *Use the optical switches*
- *Access and use the display menu system*
- *Display codes for process variables*
- *Codes and abbreviations used in display menus*
- *Menu maps for the transmitter display*

A.1 **Components of the transmitter interface**

The transmitter interface includes the status LED, the display (LCD panel), and two optical switches.

Figure A-1: Transmitter interface



- A. Status LED
 - B. Display (LCD panel)
 - C. Process variable
 - D. Scroll optical switch
 - E. Optical switch indicator
 - F. Select optical switch
 - G. Unit of measure for process variable
 - H. Current value of process variable
-

A.2 Use the optical switches

Use the optical switches on the transmitter interface to control the transmitter display. The transmitter has two optical switches: Scroll and Select.

To activate an optical switch, block the light by holding your thumb or finger in front of the opening.

Tip

You can activate the optical switch through the lens. Do not remove the transmitter housing cover.

The optical switch indicator lights up when the transmitter senses that an optical switch has been activated.

Table A-1: Optical switch indicator and optical switch states

Optical switch indicator	State of optical switches
Solid red	One optical switch is activated.
Flashing red	Both optical switches are activated.

A.3 Access and use the display menu system

The display menu system is used to perform various configuration, administrative, and maintenance tasks.

Tip

The display menu system does not provide complete configuration, administrative, or maintenance functions. For complete transmitter management, you must use another communications tool.

Prerequisites

To access the display menu system, operator access to either the Off-Line menu or the Alarm menu must be enabled. To access the complete menu system, operator access must be enabled for both the Off-Line menu and the Alarm menu.

Procedure

1. At the transmitter display, activate the Scroll and Select optical switches simultaneously until the display changes.

You will enter the Off-Line menu at any of several locations, depending on several factors.
 - If an alarm is active and access to the Alarm menu is enabled, you will see SEE ALARM.
 - If no alarm is active and Smart Meter Verification is enabled on the transmitter, you will see ENTER METER VERIFY.
 - If no alarm is active and Smart Meter Verification is not enabled on the transmitter, you will see OFF_LINE MAINT.
2. Use the Scroll and Select optical switches to navigate to your destination in the display menu system.
 - Use Scroll to move through a list of options.
 - Use Select to choose the current option.
3. If CODE? appears on the display when you make a choice, enter the value that is configured for Off-Line Password.
 - a. With the cursor flashing on the first digit, activate Scroll until the correct digit is displayed, then activate Select.
 - b. Repeat this process for the second, third, and fourth digits.

Tip

If you do not know the correct value for Off-Line Password, wait 30 seconds. The password screen will time out automatically and you will be returned to the previous screen.

4. If Scroll flashes on the display, activate the Scroll optical switch, then the Select optical switch, and then the Scroll optical switch again.

The display will prompt you through this sequence. The Scroll-Select-Scroll sequence is designed to guard against accidental activation of the off-line menu. It is not designed as a security measure.

5. To exit a display menu and return to a higher-level menu:
 - Activate Scroll until the EXIT option is displayed, then activate Select.
 - If the EXIT option is not available, activate Scroll and Select simultaneously and hold until the screen returns to the previous display.
6. To exit the display menu system, you can use either of the following methods:
 - Exit each menu separately, working your way back to the top of the menu system.
 - Wait until the display times out and returns to displaying process variable data.

A.3.1 Enter a floating-point value using the display

Certain configuration values (for example, Lower Range Value and Upper Range Value) are entered as floating-point values. The display supports both decimal notation and exponential notation for floating-point values.

The display allows you to enter a maximum of 8 characters, including the sign. The decimal point is not counted as a character. Exponential notation is used to enter values that require more than 8 characters.

Enter a floating-point value using decimal notation

Decimal notation allows you to enter values between -9999999 and 99999999. You can use the decimal point to enter values with a precision of 0 through 4 (4 characters to the right of the decimal point).

Decimal values entered via the display must meet the following requirements:

- They can contain a maximum of 8 digits, or 7 digits plus a minus sign (-) to indicate a negative number.
- They can contain a decimal point. The decimal point does not count as a digit. The decimal point must be positioned so that the precision of the value does not exceed 4.

When you first enter the configuration screen, the current configuration value is displayed in decimal notation, and the active character is flashing. If the value is positive, no sign is displayed. If the value is negative, a minus sign is displayed.

Procedure

- To change the value:
 1. Activate Select until the digit you want to change is active (flashing).
Select moves the cursor one position to the left. From the leftmost position, Select moves the cursor to the rightmost digit.
 2. Activate Scroll to change the value of the active digit.
 3. Repeat until all digits are set as desired.
- To change the sign of the value:
 - If the current value is negative, activate Select until the minus sign is flashing, then activate Scroll until the space is blank.
 - If the current value is positive and there is a blank space at the left of the value, activate Select until the cursor is flashing under the blank space, then activate Scroll until the minus sign appears.
 - If the current value is positive and there is no blank space at the left of the value, activate Select until the cursor is flashing under the leftmost digit, then activate Scroll until the minus sign appears.
- To move the decimal point:
 1. Activate Select until the decimal point is flashing.
 2. Activate Scroll.
The decimal point is removed from its current position.
 3. Activate Select and watch the position of the decimal point.
As the cursor moves to the left, the decimal point will flash between each pair of digits, up to a maximum precision of four (four digits to the right of the decimal point).

Tip
If the position is not valid, the decimal point is not displayed. Continue to activate Select until the decimal point appears at the right of the displayed value.

 4. When the decimal point is in the desired position, activate Scroll.
The decimal point is inserted at its current position.
- To save the displayed value to transmitter memory, activate Scroll and Select simultaneously and hold until the display changes.
 - If the displayed value is the same as the value in transmitter memory, you will be returned to the previous screen.
 - If the displayed value is not the same as the value in transmitter memory, SAVE/YES? flashes on the display. Activate Select.

- To exit the menu without saving the displayed value to transmitter memory, activate Scroll and Select simultaneously and hold until the display changes.
 - If the displayed value is the same as the value in transmitter memory, you will be returned to the previous screen.
 - If the displayed value is not the same as the value in transmitter memory, SAVE/YES? flashes on the display. Activate Scroll.

Enter a floating-point value using exponential notation

Exponential notation is used to enter values that are larger than 99999999 or smaller than -9999999.

Exponential values entered via the display must be in the following form: SX.XXXEYY. In this string:

- S = Sign. A minus sign (-) indicates a negative number. A blank indicates a positive number.
- X.XXX = The 4-digit mantissa.
- E = The exponent indicator.
- YY = The 2-digit exponent.

Procedure

1. Switch from decimal notation to exponential notation.
 - a. Activate Select as required until the rightmost digit is flashing.
 - b. Activate Scroll until E is displayed.
 - c. Activate Select.

Tip

If you have modified the value in decimal notation without saving the changes to transmitter memory, the changes will be lost when you switch to exponential notation. Save the decimal value before switching to exponential notation.

2. Enter the exponent.

The first character may be a minus sign or any digit between 0 and 3. The second character may be any digit between 0 and 9.

 - a. Activate Select to move the cursor to the rightmost character on the display.
 - b. Activate Scroll until the desired character is displayed.
 - c. Activate Select to move the cursor one position to the left.
 - d. Activate Scroll until the desired character is displayed.
3. Enter the mantissa.

The mantissa must be a 4-digit value with a precision of 3 (that is, all values between 0.000 and 9.999).

 - a. Activate Select to move the cursor to the rightmost digit in the mantissa.

- b. Activate Scroll until the desired character is displayed.
 - c. Activate Select to move the cursor one digit to the left.
 - d. Activate Scroll until the desired character is displayed.
 - e. Activate Select to move the cursor one digit to the left.
 - f. Activate Scroll until the desired character is displayed.
 - g. Activate Select to move the cursor one digit to the left.
 - h. Activate Scroll until the desired character is displayed.
4. Enter the sign.
 - a. Activate Select to move the cursor one digit to the left.
 - b. Activate Scroll until the desired character is displayed.

For positive numbers, select a blank space.
 5. To save the displayed value to transmitter memory, activate Scroll and Select simultaneously and hold until the display changes.
 - If the displayed value is the same as the value in transmitter memory, you will be returned to the previous screen.
 - If the displayed value is not the same as the value in transmitter memory, *SAVE/YES?* flashes on the display. Activate Select.
 6. (Optional) Switch back from exponential notation to decimal notation.
 - a. Activate Select until the E is flashing.
 - b. Activate Select until d is displayed.
 - c. Activate Select.

A.4 Display codes for process variables

Certain configuration values (for example, Lower Range Value and Upper Range Value) are entered as floating-point values. The display supports both decimal notation and exponential notation for floating-point values.

Table A-2: Display codes for process variables

Code	Definition	Comment or reference
AVE_D	Average density	
AVE_T	Average temperature	
BRD_T	Board temperature	
CONC	Concentration	
DRIVE%	Drive gain	
EXT_P	External pressure	
EXT_T	External temperature	

Table A-2: Display codes for process variables (continued)

Code	Definition	Comment or reference
FVZ	Field verification zero	Weights & Measures application only
GSV F	Gas standard volume flow	
GSV I	Gas standard volume inventory	
GSV T	Gas standard volume total	
LPO_A	Left pickoff amplitude	
LVOLI	Volume inventory	
LZERO	Live zero flow	
MASSI	Mass inventory	
MTR_T	Case temperature (T-Series sensors only)	
NET M	Net mass flow rate	Concentration measurement application only
NET V	Net volume flow rate	Concentration measurement application only
NETMI	Net mass inventory	Concentration measurement application only
NETVI	Net volume inventory	Concentration measurement application only
PWRIN	Input voltage	Refers to power input to the core processor
RDENS	Density at reference temperature	Concentration measurement application only
RPO_A	Right pickoff amplitude	
SGU	Specific gravity units	
STD V	Standard volume flow rate	Concentration measurement application only
STDVI	Standard volume inventory	Concentration measurement application only
TCDENS	Temperature-corrected density	Petroleum measurement application only
TCORI	Temperature-corrected inventory	Petroleum measurement application only
TCORR	Temperature-corrected total	Petroleum measurement application only
TCVOL	Temperature-corrected volume	Petroleum measurement application only
TUBEF	Raw tube frequency	
WTAVE	Weighted average	

A.5 Codes and abbreviations used in display menus

Table A-3: Codes and abbreviations used in display menus

Code or abbreviation	Definition	Comment or reference
ACK ALARM	Acknowledge alarm	
ACK ALL	Acknowledge all alarms	
ACT	Action	
ADDR	Address	
AO 1 SRC	Fixed to the process variable assigned to the primary output	
AO1	Analog output 1 (primary mA output)	
AO2	Analog output 2 (secondary mA output)	
AUTO SCROLL	Auto Scroll	
BKLT B LIGHT	Backlight	
CAL	Calibrate	
CH A	Channel A	
CH B	Channel B	
CH C	Channel C	
CHANGE PASSW CHANGE CODE	Change password or passcode	Change the password or passcode required for access to display functions
CONFIG	Configuration	
CORE	Core processor	
CUR Z	Current zero	
CUSTODY XFER	Custody transfer	
DEV	Discrete event	Events configured using the enhanced event model
DENS	Density	
DGAIN, DRIVE %	Drive gain	
DI	Discrete input	
DISBL	Disable	Select to disable
DO1	Discrete output 1	
DO2	Discrete output 2	
DSPLY	Display	
E1OR2	Event 1 or Event 2	Events configured using the basic event model
ENABL	Enable	Select to enable
ENABLE ACK	Enable acknowledge all	Enable or disable the ACK ALL function

Table A-3: Codes and abbreviations used in display menus (continued)

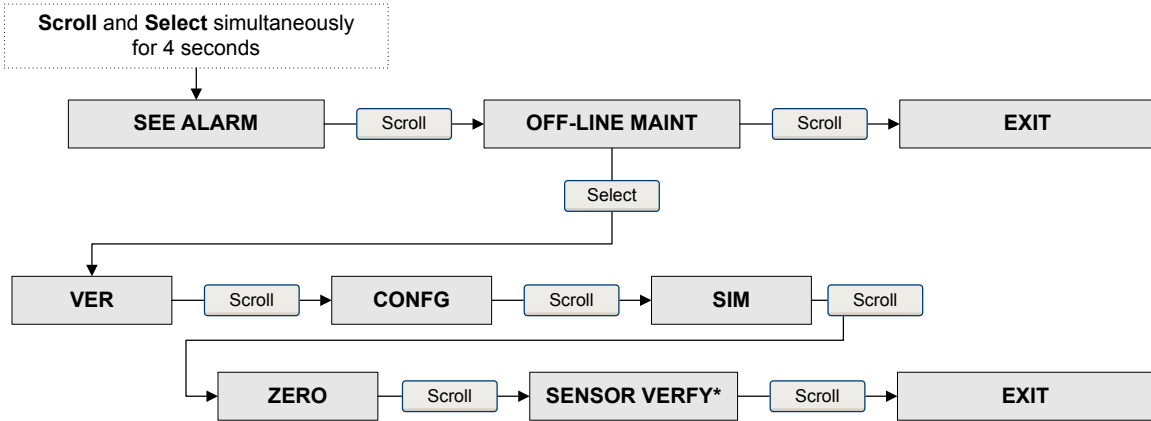
Code or abbreviation	Definition	Comment or reference
ENABLE ALARM	Enable alarm menu	Access to alarm menu from display
ENABLE AUTO	Enable Auto Scroll	Enable or disable the Auto Scroll function
ENABLE OFFLN	Enable off-line	Access to off-line menu from display
ENABLE PASSW	Enable password	Enable or disable password protection for display functions
ENABLE RESET	Enable totalizer reset	Enable or disable totalizer reset from display
ENABLE START	Enable totalizer start	Enable or disable totalizer start/stop from display
EVNT1	Event 1	Event configured using the basic event model only
EVNT2	Event 2	Event configured using the basic event model only
EXTRN	External	
FAC Z	Factory zero	
FCF	Flow calibration factor	
FL SW FLSWT	Flow switch	
FLDIR	Flow direction	
FO	Frequency output	
FO FREQ	Frequency factor	
FO RATE	Rate factor	
FR FL	Frequency=Flow	
FREQ	Frequency	
GSV	Gas standard volume	
HYSTRSIS	Hysteresis	
INTERN	Internal	
IO	Input/output	
LANG	Language	
LOCK	Write-protect	
LOOP CUR	Loop current	
MTR F	Meter factor	
M_ASC	Modbus ASCII	
M_RTU	Modbus RTU	
MAO1	mA output 1 (primary mA output)	
MAO2	mA output 2 (secondary mA output)	

Table A-3: Codes and abbreviations used in display menus (continued)

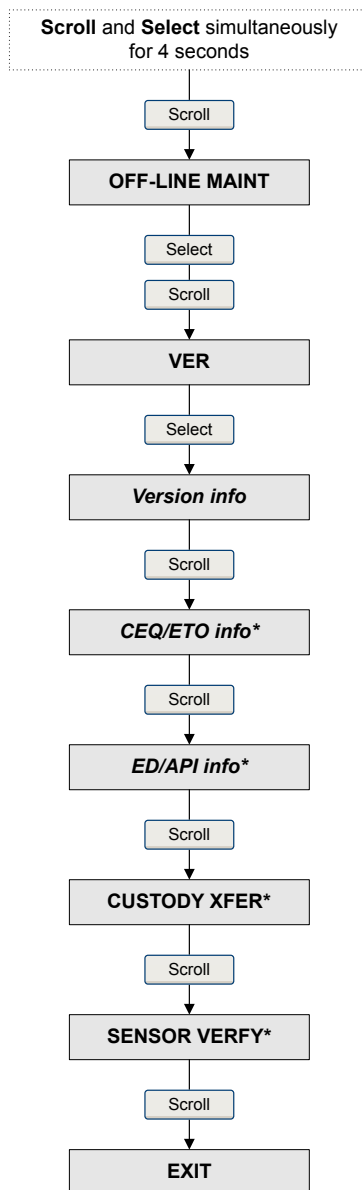
Code or abbreviation	Definition	Comment or reference
MASS	Mass flow	
MBUS	Modbus	
MFLOW	Mass flow	
MSMT	Measurement	
OFFLN	Off-line	
OFF-LINE MAINT	Off-line maintenance	
P/UNT	Pulses/unit	
POLAR	Polarity	
PRESS	Pressure	
QUAD	Quadrature	
r.	Revision	
SCALE	Scaling method	
SIM	Simulation	Used for loop testing, not simulation mode. Simulation mode is not accessible via the display.
SPECL	Special	
SRC	Source	Variable assignment
TEMP, TEMPR	Temperature	
UNT/P	Units/pulse	
VAR 1	Display Variable 1	
VER	Version	
VERFY	Verify	
VFLOW	Volume flow	
VOL	Volume, volume flow	
WRPRO	Write protect	
XMTR	Transmitter	

A.6 Menu maps for the transmitter display

Figure A-2: Offline menu – top level



**This option is displayed only if the transmitter is connected to an enhanced core processor and the meter verification software is installed on the transmitter.*

Figure A-3: Offline menu – version information

**The option is displayed only if the corresponding CEQ/ETO or application is installed on the transmitter.*

Figure A-4: Offline menu – configuration: units and I/O

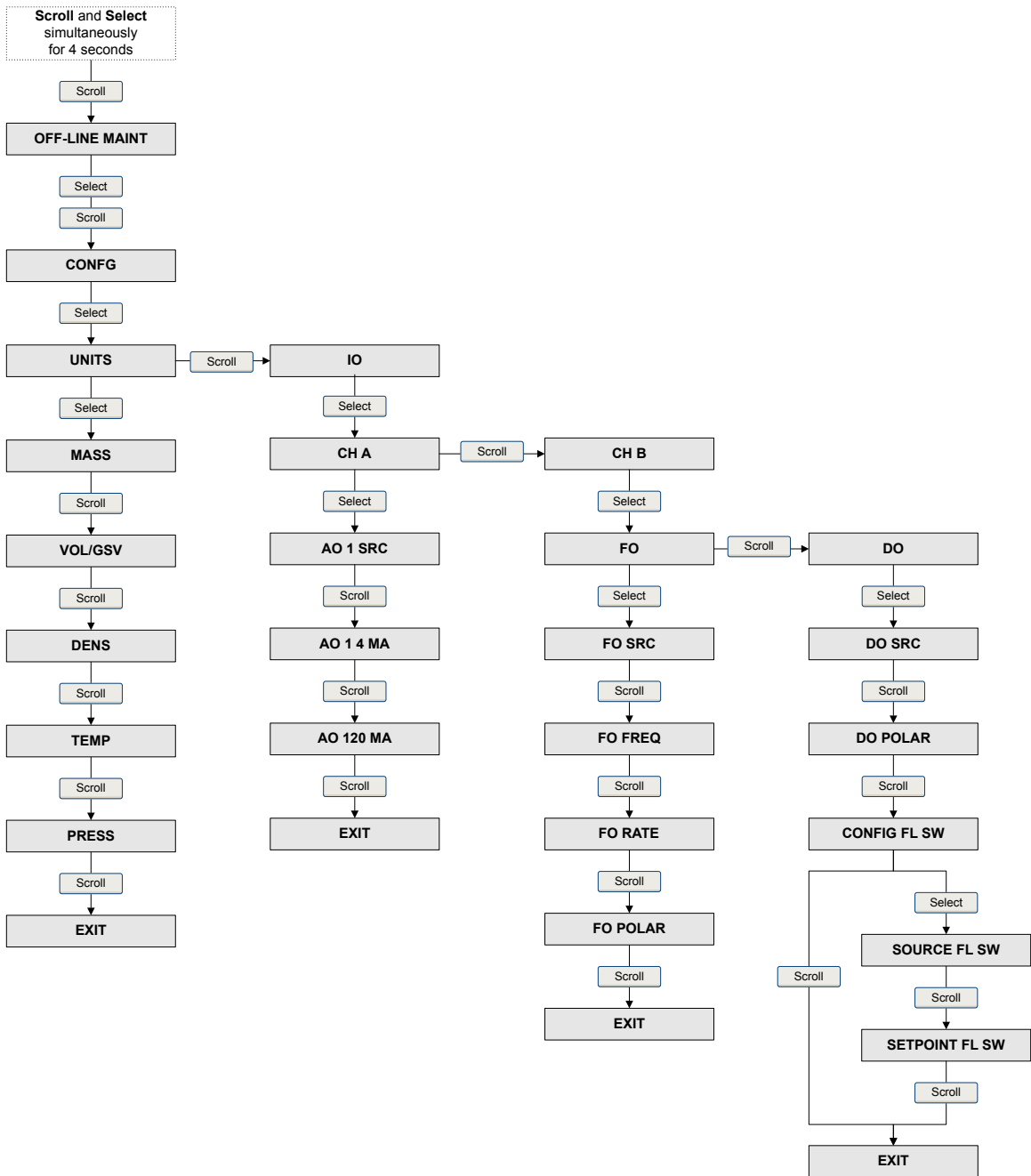


Figure A-5: Offline menu – configuration: meter factor, display, and digital communications

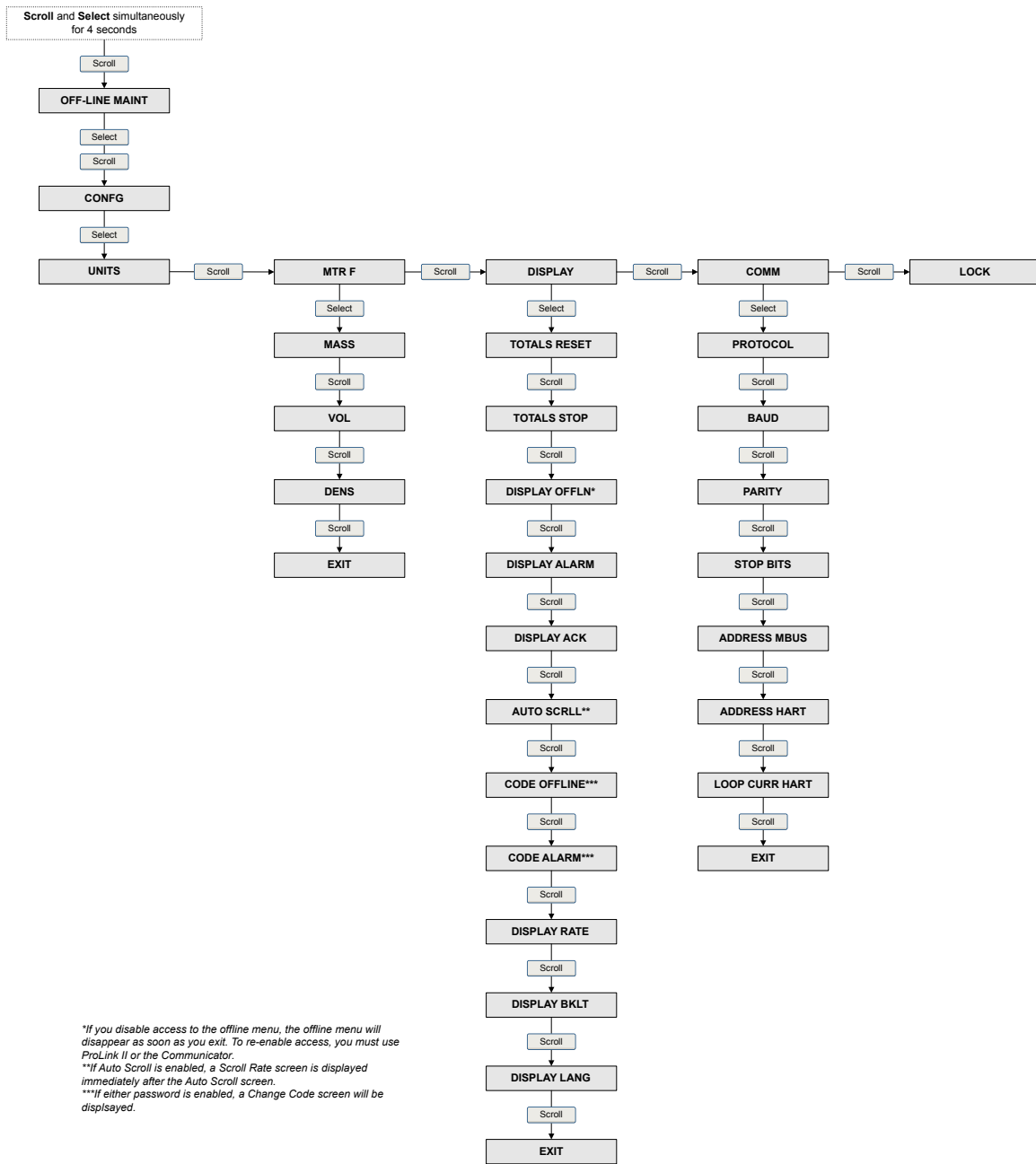
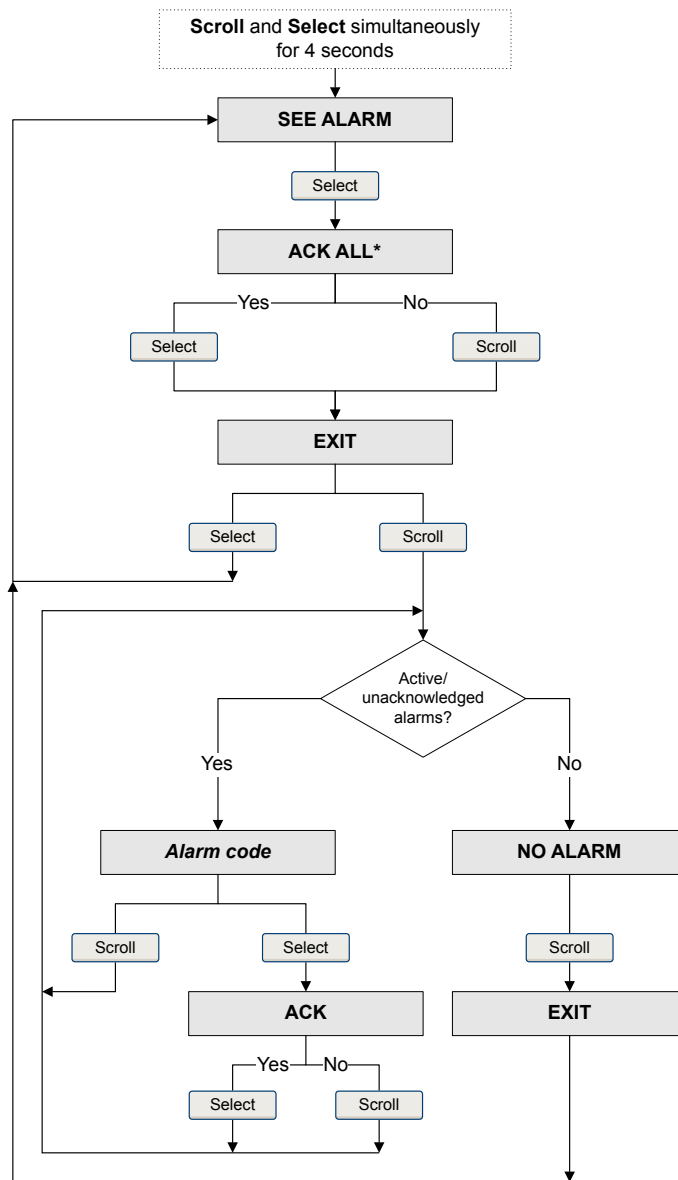


Figure A-6: Offline menu – alarms



**This screen is displayed only if the ACK ALL function is enabled and there are unacknowledged alarms.*

Figure A-7: Offline menu – meter verification: top level

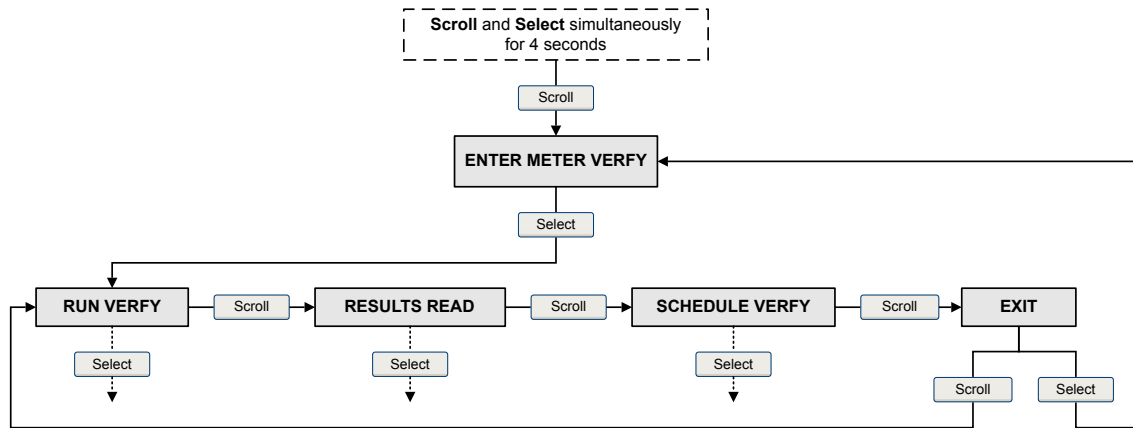


Figure A-8: Offline menu – meter verification schedule

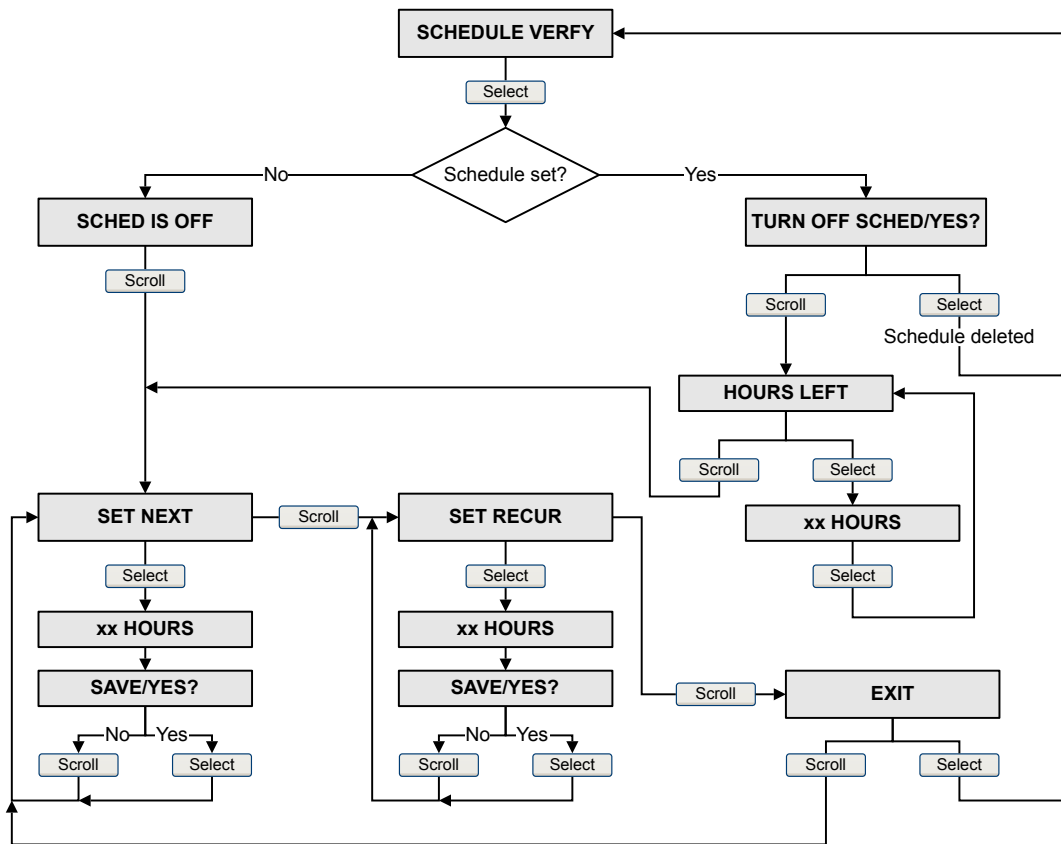


Figure A-9: Offline menu – meter verification test

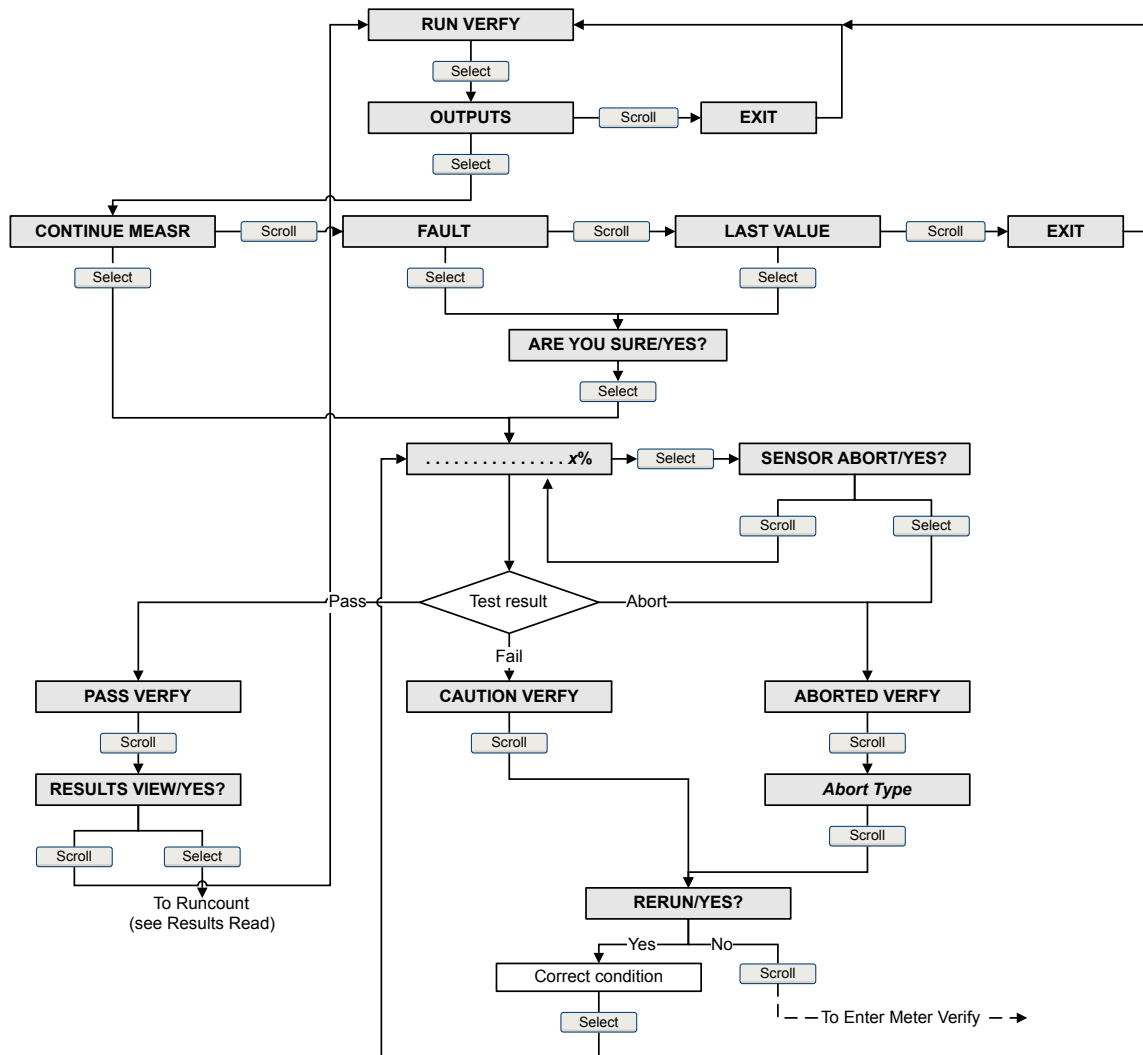


Figure A-10: Offline menu – meter verification results

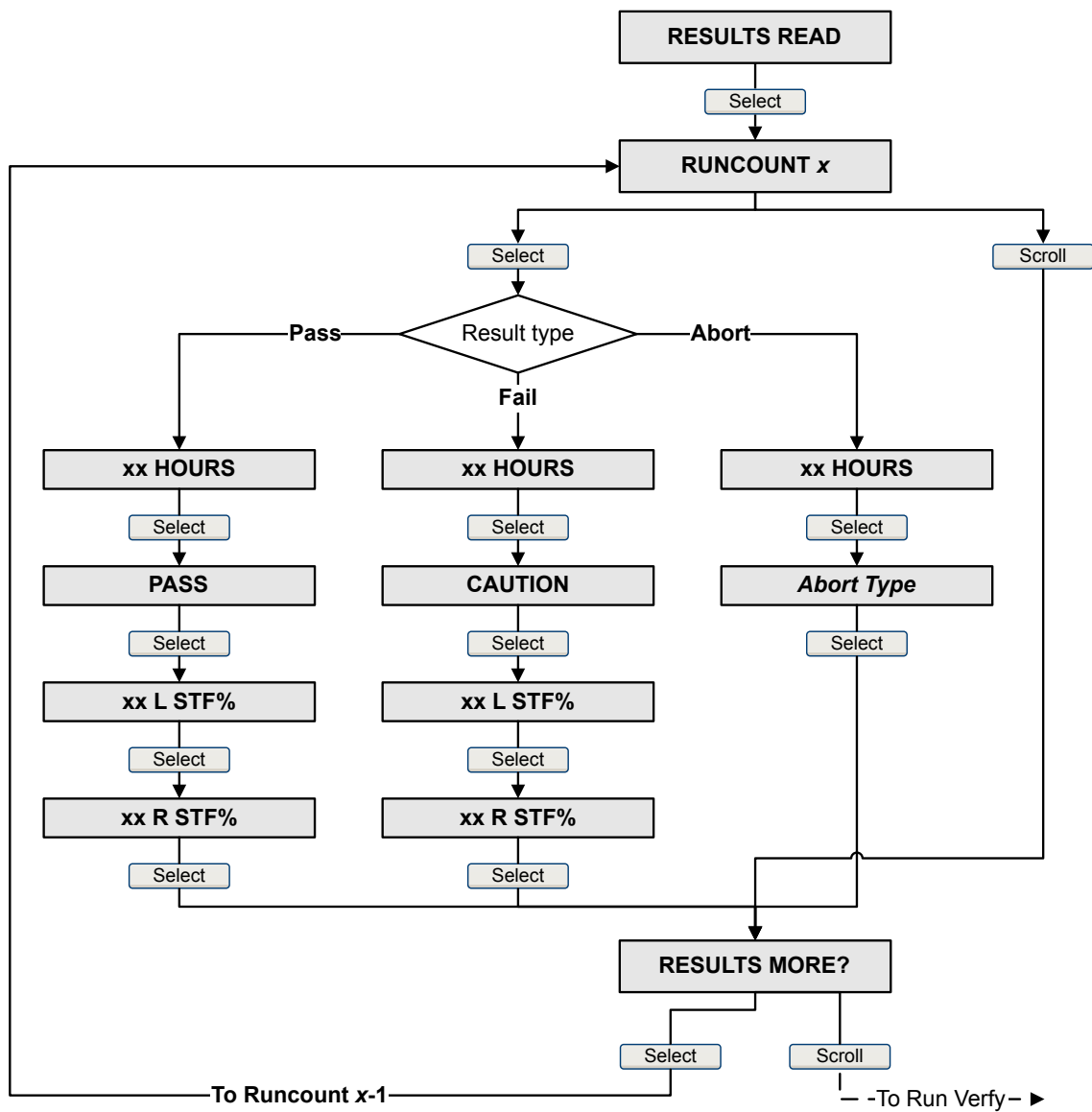
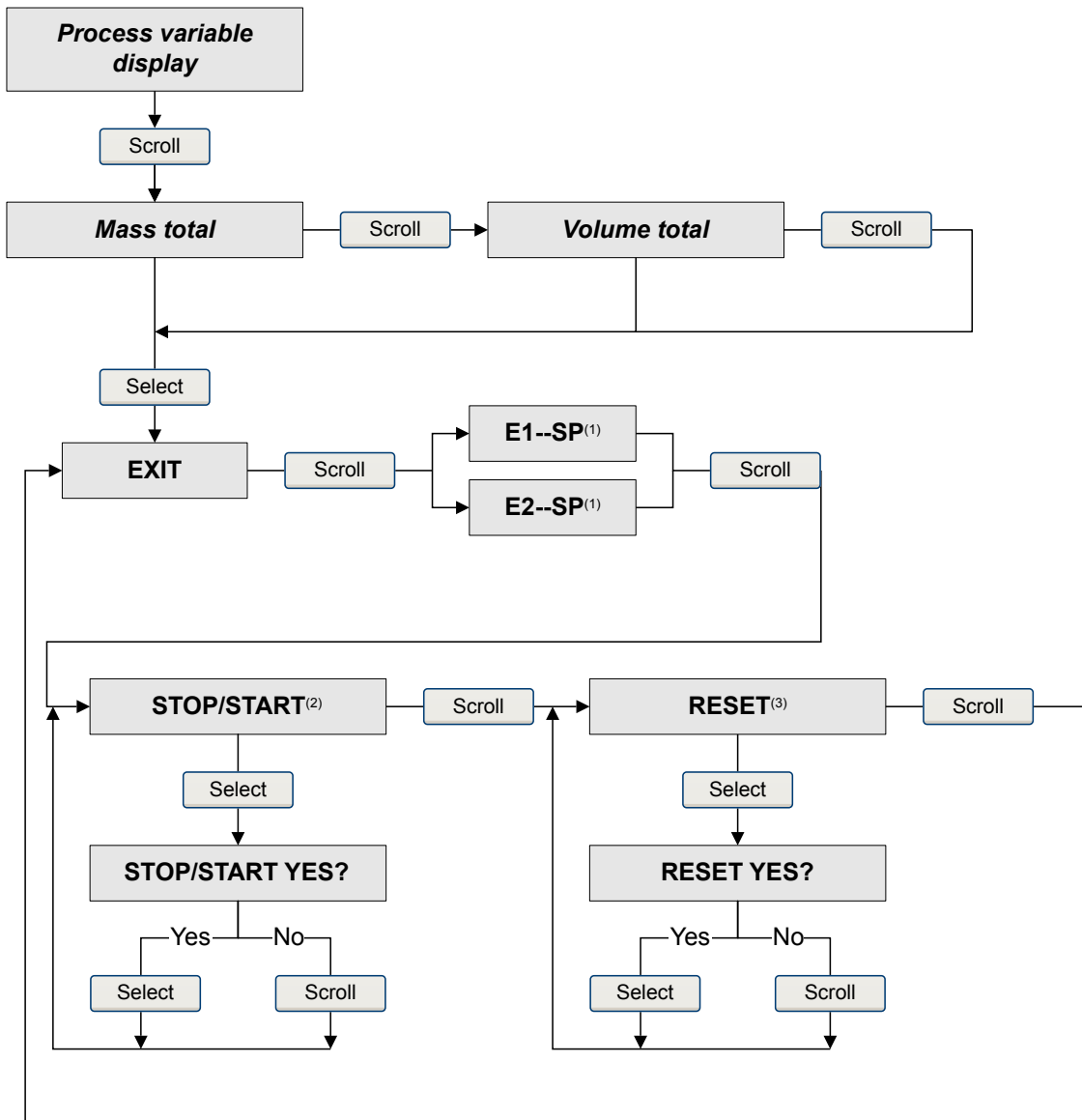


Figure A-11: Offline menu – totalizers and inventories



(1) The Event Setpoint screens can be used to define or change the setpoint for Event 1 or Event 2 in the basic event model. These screens are displayed only if the event is defined on mass total or volume total. Note that this functionality does not apply to discrete events (the enhanced event model).

(2) The transmitter must be configured to allow starting and stopping totalizers from the display.

(3) The transmitter must be configured to allow resetting totalizers from the display.

Figure A-12: Offline menu – Simulation (loop testing)

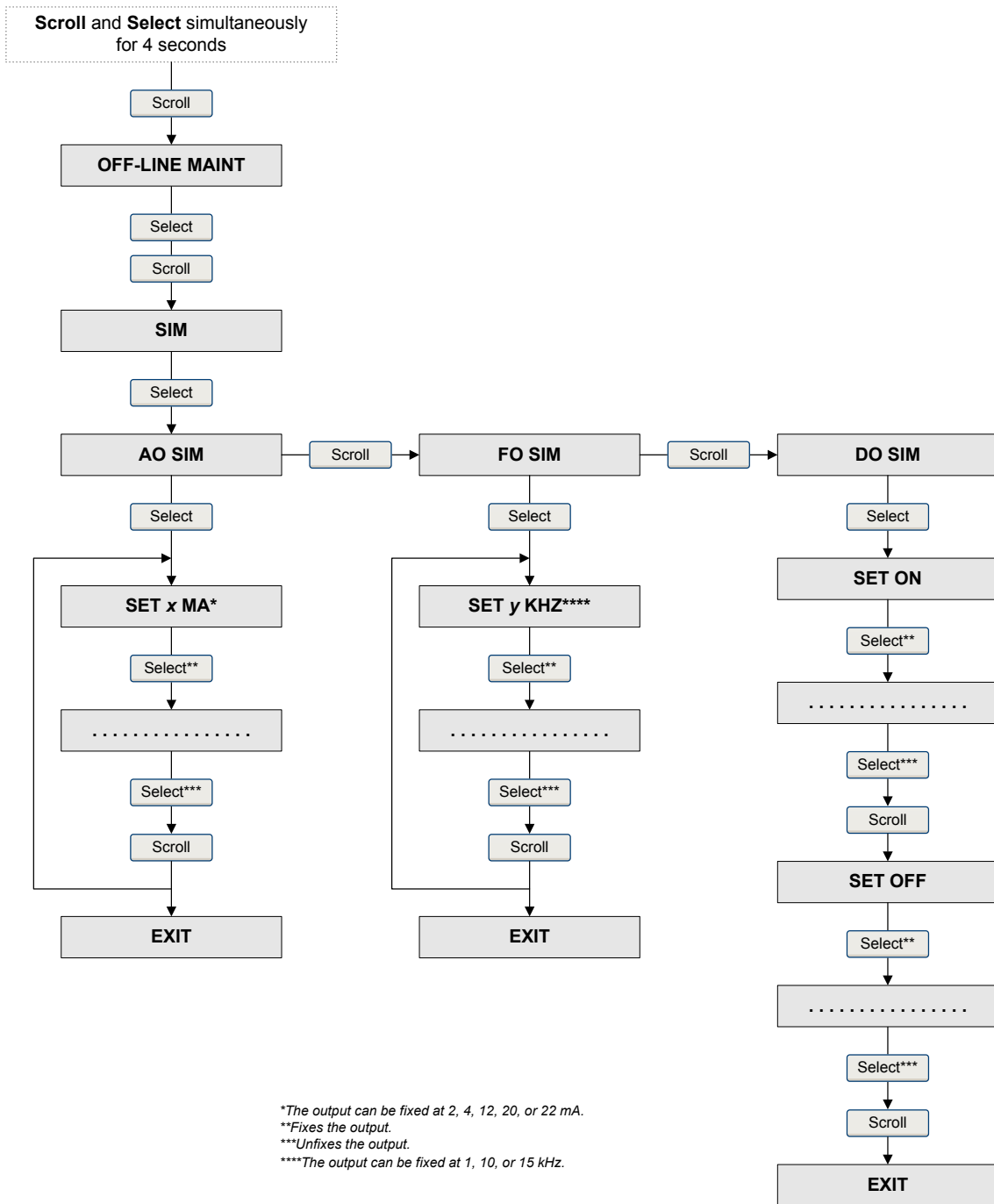
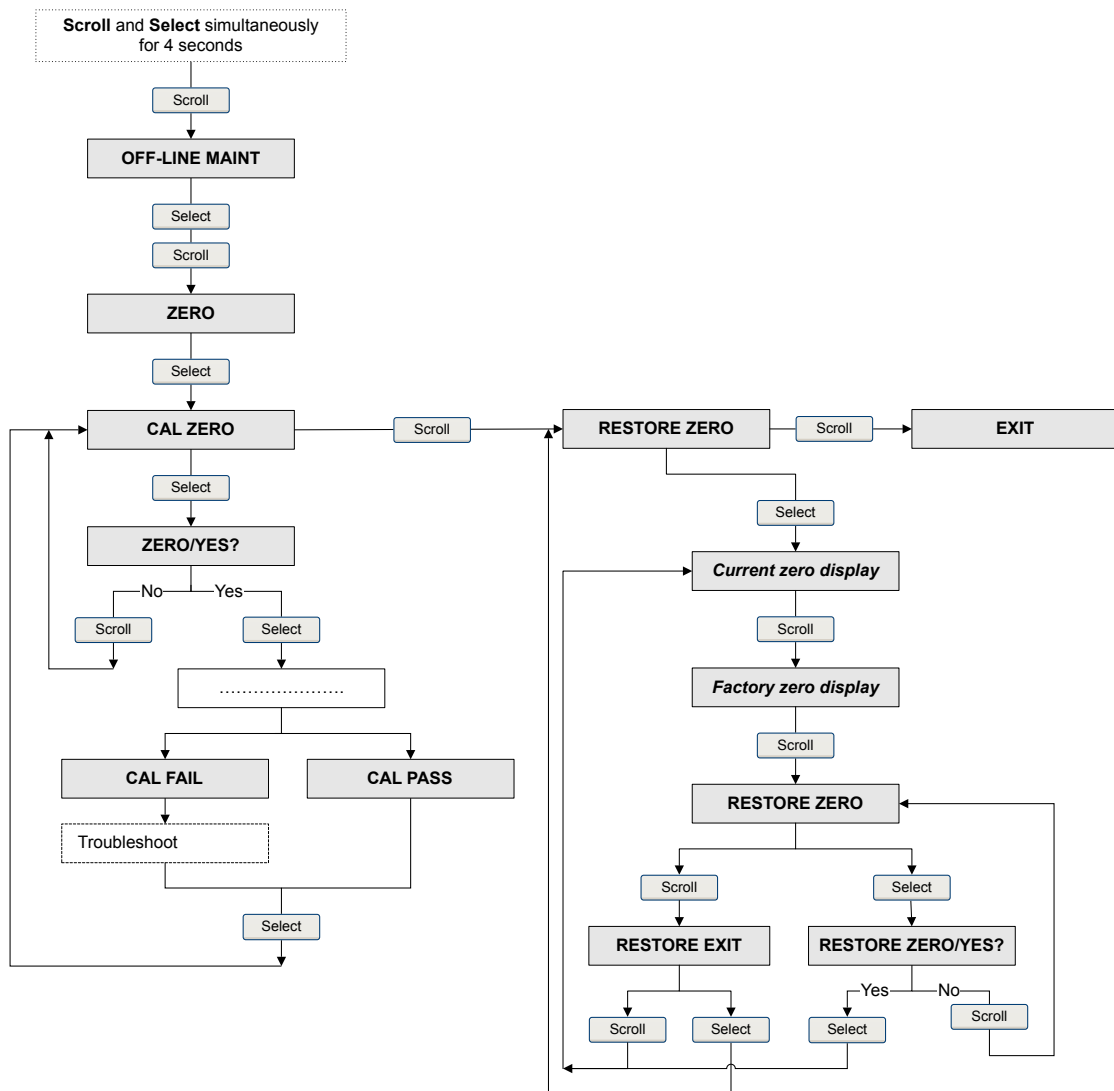


Figure A-13: Offline menu – Zero



Appendix B

Using ProLink II with the transmitter

Topics covered in this appendix:

- [Basic information about ProLink II](#)
- [Connect with ProLink II](#)
- [Menu maps for ProLink II](#)

B.1 Basic information about ProLink II

ProLink II is a software tool available from Micro Motion. It runs on a Windows platform and provides complete access to transmitter functions and data.

ProLink II requirements

To install ProLink II, you must have:

- The ProLink II installation media
- The ProLink II installation kit for your connection type

To obtain ProLink II and the appropriate installation kit, contact Micro Motion.

ProLink II documentation

Most of the instructions in this manual assume that you are already familiar with ProLink II or that you have a general familiarity with Windows programs. If you need more information than this manual provides, see the ProLink II manual (*ProLink® II Software for Micro Motion® Transmitters: Installation and Use Manual*).

In most ProLink II installations, the manual is installed with the ProLink II program. Additionally, the ProLink II manual is available on the Micro Motion documentation CD or the Micro Motion web site (www.micromotion.com).

ProLink II features and functions

ProLink II offers complete transmitter configuration and operation functions. ProLink II also offers a number of additional features and functions, including:

- The ability to save the transmitter configuration set to a file on the PC, and reload it or propagate it to other transmitters
- The ability to log specific types of data to a file on the PC
- A commissioning wizard
- A proving wizard
- A gas wizard

These features are documented in the ProLink II manual. They are not documented in the current manual.

ProLink II messages

As you use ProLink II with a Micro Motion transmitter, you will see a number of messages and notes. This manual does not document all of these messages and notes.

Important

The user is responsible for responding to messages and notes and complying with all safety messages.

B.2 Connect with ProLink II

A connection from ProLink II to your transmitter allows you to read process data, configure the transmitter, and perform maintenance and troubleshooting tasks.

B.2.1 ProLink II connection types

Different connection types are available for connecting from ProLink II to the transmitter. Choose the connection type appropriate to your network and the tasks you intend to perform.

The transmitter supports the following ProLink II connection types:

- Service port connections
- HART/Bell 202 connections
- HART/RS-485 connections
- Modbus/RS-485 7-bit connections (Modbus ASCII)
- Modbus/RS-485 8-bit connections (Modbus RTU)

When selecting a connection type, consider the following:

- Service port connections use standard connection parameters that are already defined in ProLink II, and therefore you do not have to configure them.
- HART/Bell 202 connections use standard HART connection parameters that are already defined in ProLink II. The only parameter you must configure is the transmitter address.
- Some connection types require opening the wiring compartment or the power supply compartment. These connection types should be used only for temporary connections, and may require extra safety precautions.
- Modbus connections, including service port connections, are typically faster than HART connections.
- When you are using a HART connection, ProLink II will not allow you to open more than one window at a time. This is done to manage network traffic and optimize speed.
- You cannot make concurrent connections if the connections use the same terminals. You can make concurrent connections if the connections use different terminals.

B.2.2 Make a service port connection

CAUTION!

If the transmitter is in a hazardous area, do not use a service port connection. Service port connections require opening the wiring compartment, and opening the wiring compartment while the transmitter is powered up could cause an explosion. To connect to the transmitter in a hazardous environment, use a connection method that does not require removing the transmitter housing cover.

Prerequisites

- ProLink II installed and licensed on your PC
- One of the following:
 - RS-232 to RS-485 signal converter
 - USB to RS-485 signal converter
- An available serial port or USB port
- Adapters as required (for example, 9-pin to 25-pin)

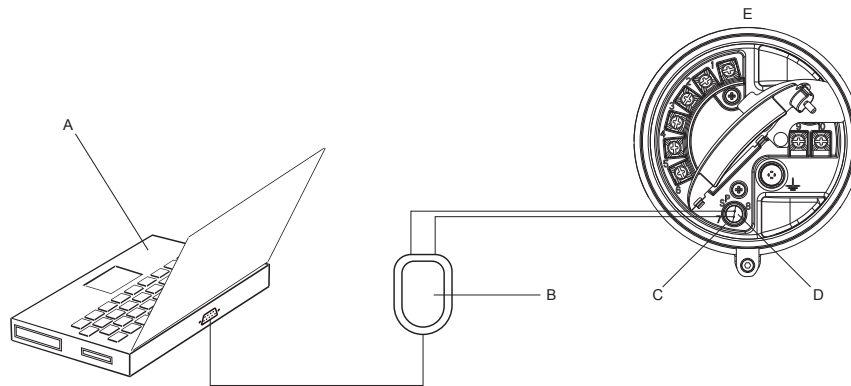
Procedure

1. Attach the signal converter to the serial port or USB port on your PC.
2. Access the service port terminals:
 - a. Remove the transmitter end-cap to access the wiring compartment.
 - b. Loosen the screw on the Warning flap and open the power supply compartment.
3. Connect the leads from the signal converter to the service port, terminals 7 (RS-485/A) and 8 (RS-485/B).

Tip

Usually, but not always, the black lead is RS-485/A and the red lead is RS-485/B.

Figure B-1: Connection to service port



- A. PC
- B. Signal converter
- C. Service port terminal 7 (RS-485/A)
- D. Service port terminal 8 (RS-485/B)
- E. Transmitter, with wiring compartment and power supply compartment opened

Note

This figure shows a serial port connection. USB connections are also supported.

4. Start ProLink II.
5. Choose Connection > Connect to Device.
6. Set Protocol to Service Port.

Tip

Service port connections use standard connection parameters and a standard address. You do not need to configure them here.

7. Set the COM Port value to the PC COM port that you are using for this connection.
8. Click Connect.

Need help? If an error message appears:

- Switch the leads and try again.
- Ensure that you have specified the correct COM port.
- Check the physical connection between the PC and the transmitter.

B.2.3 Make a HART/Bell 202 connection

You can connect directly to the mA terminals on the transmitter, to any point in a local HART loop, or to any point in a HART multidrop network.

⚠ CAUTION!

If the transmitter is in a hazardous area, do not connect directly to the transmitter terminals. Connecting directly to the transmitter terminals requires opening the wiring compartment, and opening the wiring compartment while the transmitter is powered up could cause an explosion. To connect to the transmitter in a hazardous environment, use a connection method that does not require opening the wiring compartment.

⚠ CAUTION!

If you connect directly to the mA terminals, the transmitter's mA output may be affected. If you are using the mA output for flow control, set devices for manual control before connecting directly to the mA terminals.

Prerequisites

- ProLink II installed and licensed on your PC
- One of the following:
 - RS-232 to Bell 202 signal converter
 - USB to Bell 202 signal converter
- An available serial port or USB port
- Adapters as required (for example, 9-pin to 25-pin)

Procedure

1. Attach the signal converter to the serial port or USB port on your PC.
2. To connect directly to the transmitter terminals:
 - a. Remove the transmitter end-cap to access the wiring compartment.
 - b. Connect the leads from the signal converter to terminals 1 and 2.

Tip

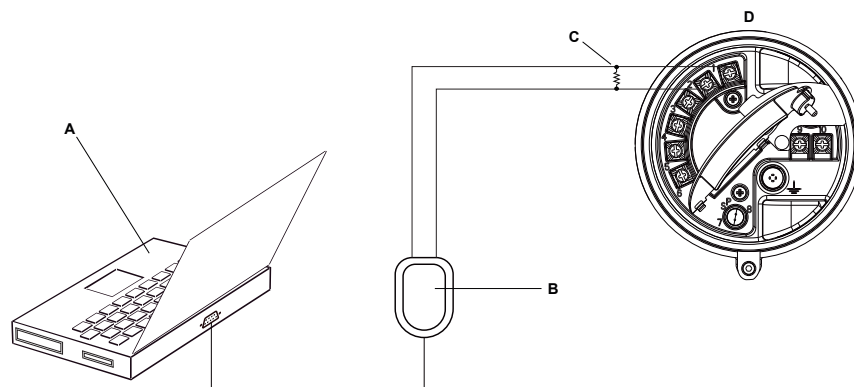
HART connections are not polarity-sensitive. It does not matter which lead you attach to which terminal.

- c. Add resistance as necessary.

Important

HART/Bell 202 connections require a voltage drop of 1 VDC. To achieve this, add resistance of 250–600 Ω to the connection.

Figure B-2: Connection to transmitter terminals



- A. PC
- B. Signal converter
- C. 250–600 Ω resistance
- D. Transmitter, with wiring compartment and power supply compartment opened

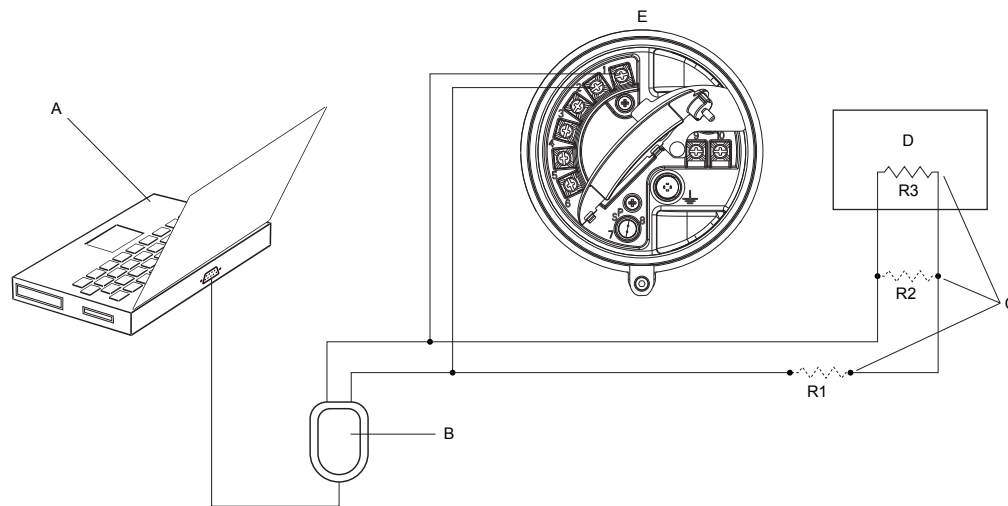
Note

This figure shows a serial port connection. USB connections are also supported.

3. To connect from a point in the local HART loop:
 - a. Attach the leads from the signal converter to any point in the loop.
 - b. Add resistance as necessary.

Important

HART/Bell 202 connections require a voltage drop of 1 VDC. To achieve this, add resistance of 250–600 Ω to the connection.

Figure B-3: Connection over local loop

- A. PC
- B. Signal converter
- C. Any combination of resistors R1, R2, and R3 as necessary to meet HART communication resistance requirements
- D. DCS or PLC
- E. Transmitter, with wiring compartment and power supply compartment opened

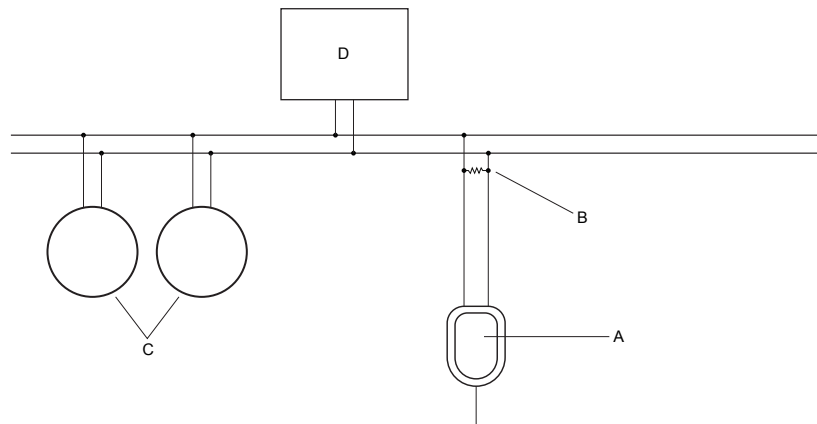
Note

This figure shows a serial port connection. USB connections are also supported.

4. To connect over a HART multidrop network:
 - a. Attach the leads from the signal converter to any point on the network.
 - b. Add resistance as necessary.

Important

HART/Bell 202 connections require a voltage drop of 1 VDC. To achieve this, add resistance of 250–600 Ω to the connection.

Figure B-4: Connection over multidrop network

- A. Signal converter
- B. 250–600 Ω resistance
- C. Devices on the network
- D. Master device

5. Start ProLink II.
6. Choose Connection > Connect to Device.
7. Set Protocol to HART Bell 202.

Tip

HART/Bell 202 connections use standard connection parameters. You do not need to configure them here.

8. If you are using a USB signal converter, enable Converter Toggles RTS.
9. Set Address/Tag to the HART polling address configured in the transmitter.

Tips

- If this is the first time you are connecting to the transmitter, use the default address: 0.
- If you are not in a HART multidrop environment, the HART polling address is typically left at the default value.
- If you are unsure of the transmitter's address, click Poll. The program will search the network and return a list of the transmitters that it detects.

10. Set the COM Port value to the PC COM port that you are using for this connection.
11. Set Master as appropriate.

Option	Description
Secondary	Use this setting if another HART host such as a DCS is on the network.

Option	Description
Primary	Use this setting if no other host is on the network. The Field Communicator is not a host.

12. Click Connect.

Need help? If an error message appears:

- Verify the HART address of the transmitter.
- Ensure that you have specified the correct COM port.
- Check the physical connection between the PC and the transmitter.
- Increase or decrease resistance.
- Ensure that there is no conflict with another HART master.

B.2.4 Make a HART/RS-485 connection

You can connect directly to the RS-485 terminals on the transmitter or to any point on the network.

CAUTION!

If the transmitter is in a hazardous area, do not connect directly to the transmitter terminals. Connecting directly to the transmitter terminals requires opening the wiring compartment, and opening the wiring compartment while the transmitter is powered up could cause an explosion. To connect to the transmitter in a hazardous environment, use a connection method that does not require opening the wiring compartment.

Prerequisites

- ProLink II installed and licensed on your PC
- One of the following:
 - RS-232 to RS-485 signal converter
 - USB to RS-485 signal converter
- An available serial port or USB port
- Adapters as required (for example, 9-pin to 25-pin)

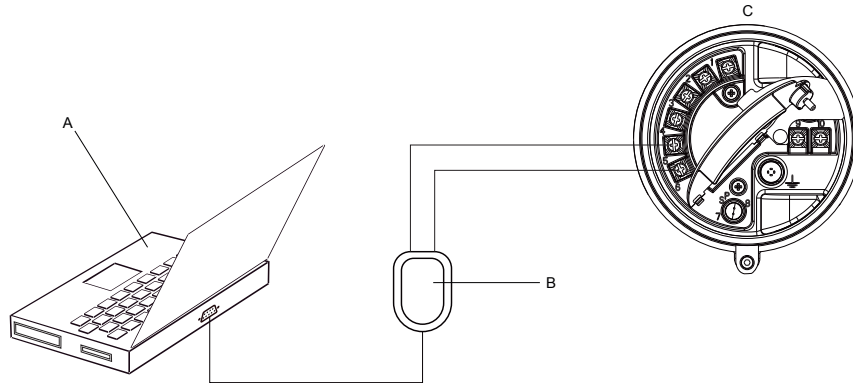
Procedure

1. Attach the signal converter to the serial port or USB port on your PC.
2. To connect directly to the transmitter terminals:
 - a. Remove the transmitter end-cap to access the wiring compartment.
 - b. Connect the leads from the signal converter to terminals 5 (RS-485/A) and 6 (RS-485/B).

Tip

HART connections are not polarity-sensitive. It does not matter which lead you attach to which terminal.

Figure B-5: Connection to transmitter terminals

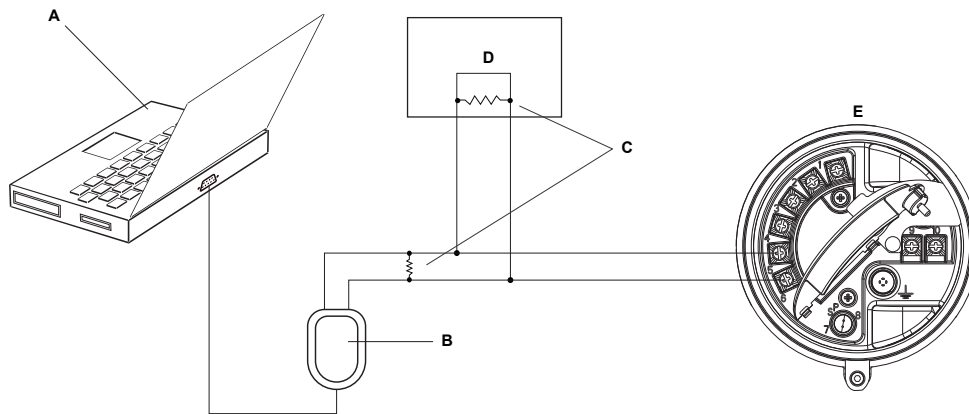


- A. PC
- B. Signal converter
- C. Transmitter, with wiring compartment and power supply compartment opened

Note

This figure shows a serial port connection. USB connections are also supported.

3. To connect over the RS-485 network:
 - a. Attach the leads from the signal converter to any point on the network.
 - b. Add resistance as necessary.

Figure B-6: Connection over network

- A. PC
- B. Signal converter
- C. 120- Ω , 1/2-watt resistors at both ends of the segment, if necessary
- D. DCS or PLC
- E. Transmitter, with wiring compartment and power supply compartment opened

Note

This figure shows a serial port connection. USB connections are also supported.

4. Start ProLink II.
5. Choose Connection > Connect to Device.
6. Set the connection parameters to the values configured in the transmitter.
If your transmitter has not been configured, use the default values shown here.

Table B-1: Default HART/RS-485 connection parameters

Parameter	Default values
Protocol	HART
Baud	1200
Parity	Odd
Stop Bits	1
Address	0

Tip

If you do not know the transmitter's RS-485 communication settings, you can connect through the service port, which always uses default settings, or use another communications tool to view or change the settings.

7. Set the COM Port value to the PC COM port that you are using for this connection.
8. Set Master as appropriate.

Option	Description
Secondary	Use this setting if another HART host such as a DCS is on the network.
Primary	Use this setting if no other host is on the network. The Field Communicator is not a host.

- Click Connect.

Need help? If an error message appears:

- Verify the HART address of the transmitter.
- Ensure that you have specified the correct COM port.
- Check the physical connection between the PC and the transmitter.
- Ensure that there is no conflict with another HART master.
- For long-distance communication, or if noise from an external source interferes with the signal, install 120-Ω ½-W terminating resistors in parallel with the output at both ends of the communication segment.

B.2.5 Make a Modbus/RS-485 connection

You can connect directly to the RS-485 terminals on the transmitter or to any point on the network.

CAUTION!

If the transmitter is in a hazardous area, do not connect directly to the transmitter terminals. Connecting directly to the transmitter terminals requires opening the wiring compartment, and opening the wiring compartment while the transmitter is powered up could cause an explosion. To connect to the transmitter in a hazardous environment, use a connection method that does not require opening the wiring compartment.

Prerequisites

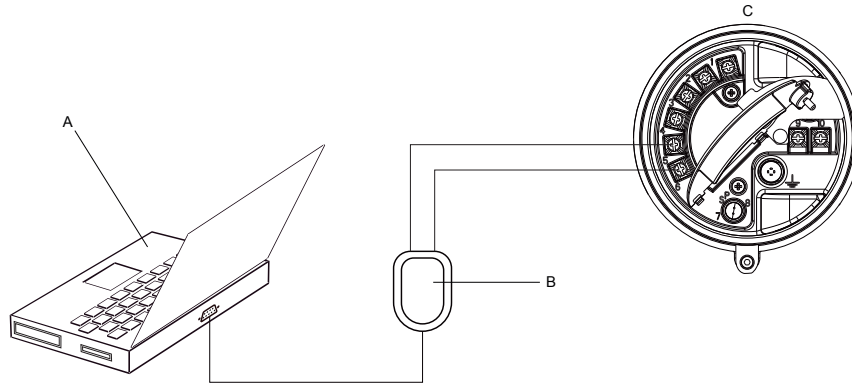
- ProLink II installed and licensed on your PC
- One of the following:
 - RS-232 to RS-485 signal converter
 - USB to RS-485 signal converter
- An available serial port or USB port
- Adapters as required (for example, 9-pin to 25-pin)

Procedure

- Attach the signal converter to the serial port or USB port on your PC.
- To connect directly to the transmitter terminals:
 - Remove the transmitter end-cap to access the wiring compartment.
 - Connect the leads from the signal converter to terminals 5 (RS-485/A) and 6 (RS-485/B).

Tip

Usually, but not always, the black lead is RS-485/A and the red lead is RS-485/B.

Figure B-7: Connection to transmitter terminals

A. PC

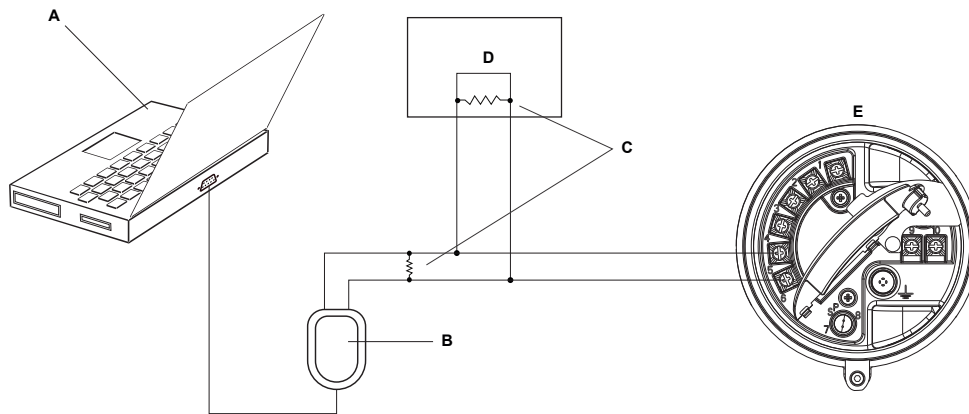
B. Signal converter

C. Transmitter, with wiring compartment and power supply compartment opened

Note

This figure shows a serial port connection. USB connections are also supported.

3. To connect over the RS-485 network:
 - a. Attach the leads from the signal converter to any point on the network.
 - b. Add resistance as necessary.

Figure B-8: Connection over network

- A. PC
- B. Signal converter
- C. 120- Ω , 1/2-watt resistors at both ends of the segment, if necessary
- D. DCS or PLC
- E. Transmitter, with wiring compartment and power supply compartment opened

Note

This figure shows a serial port connection. USB connections are also supported.

4. Start ProLink II.
5. Choose Connection > Connect to Device.
6. Set the connection parameters to the values configured in the transmitter.

If your transmitter has not been configured, use the default values shown here.

Table B-2: Default Modbus/RS-485 connection parameters

Parameter	Default value
Protocol	Modbus RTU
Baud	9600
Parity	Odd
Stop Bits	1
Address	1

Tip

If you do not know the transmitter's RS-485 communication settings, you can connect through the service port, which always uses default settings, or use another communications tool to view or change the settings.

7. Set the COM Port value to the PC COM port that you are using for this connection.
8. Click Connect.

Need help? If an error message appears:

- Verify the Modbus address of the transmitter.
- Ensure that you have specified the correct COM port.
- Check the physical connection between the PC and the transmitter.
- Increase or decrease resistance.
- For long-distance communication, or if noise from an external source interferes with the signal, install 120-Ω ½-W terminating resistors in parallel with the output at both ends of the communication segment.
- Ensure that there is no concurrent Modbus communication to the transmitter.

B.3 Menu maps for ProLink II

Figure B-9: Main menu

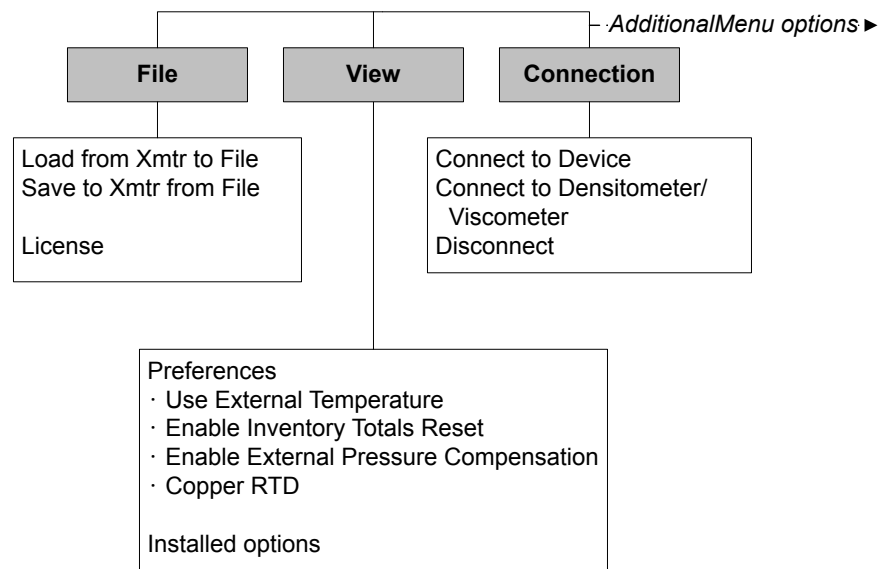
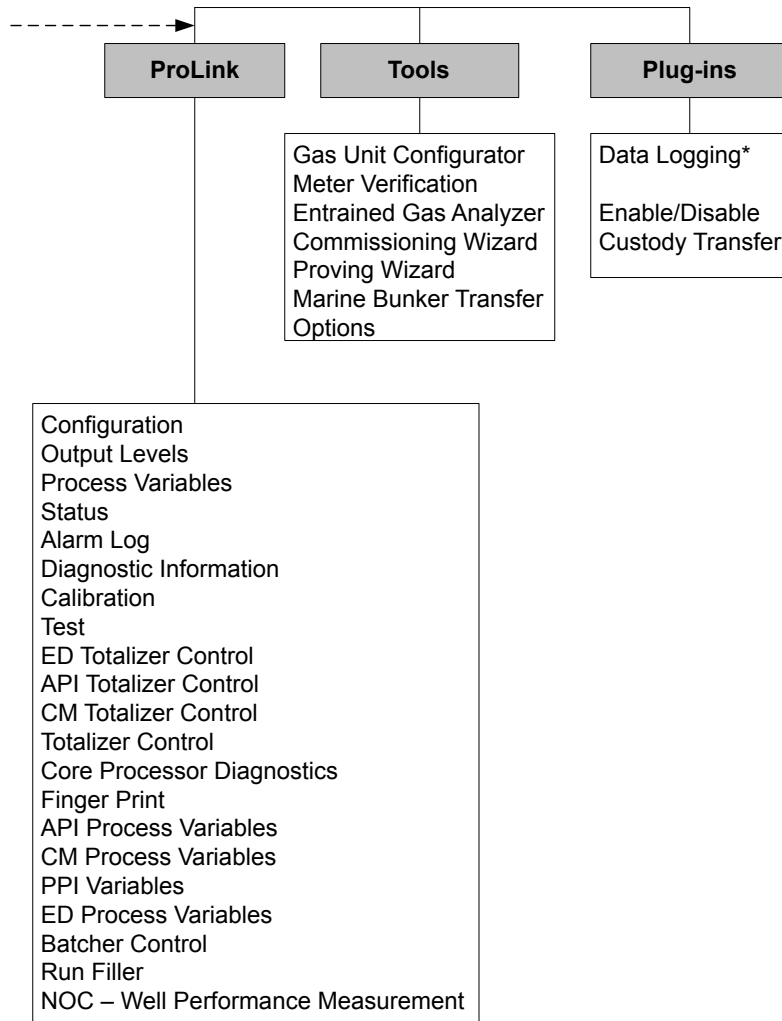


Figure B-10: Main menu (continued)



**For information about using Data Logger, refer to the ProLink II manual.*

Figure B-11: Configuration menu

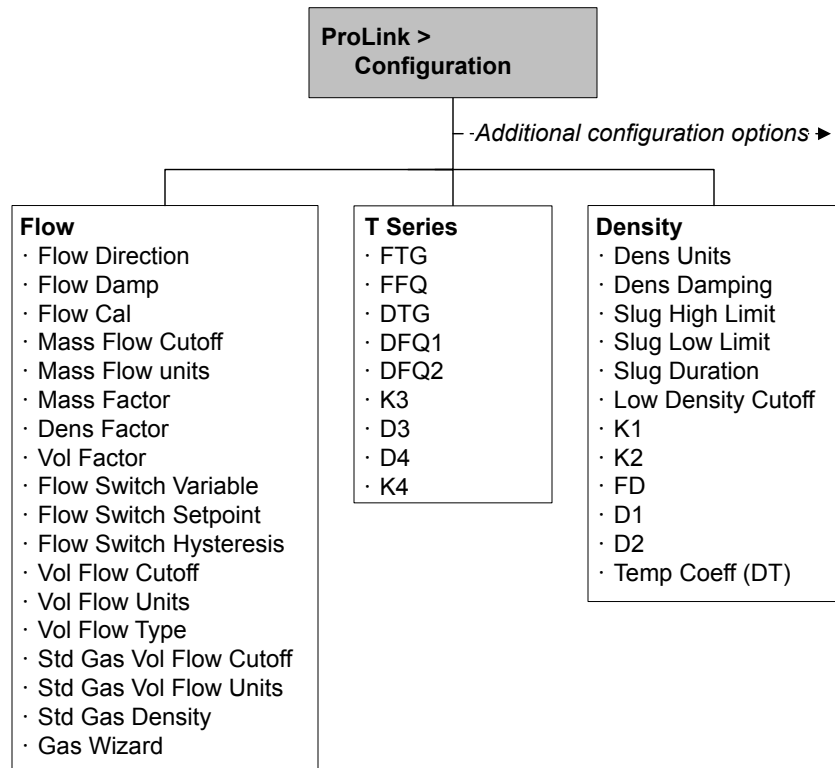


Figure B-12: Configuration menu (continued)

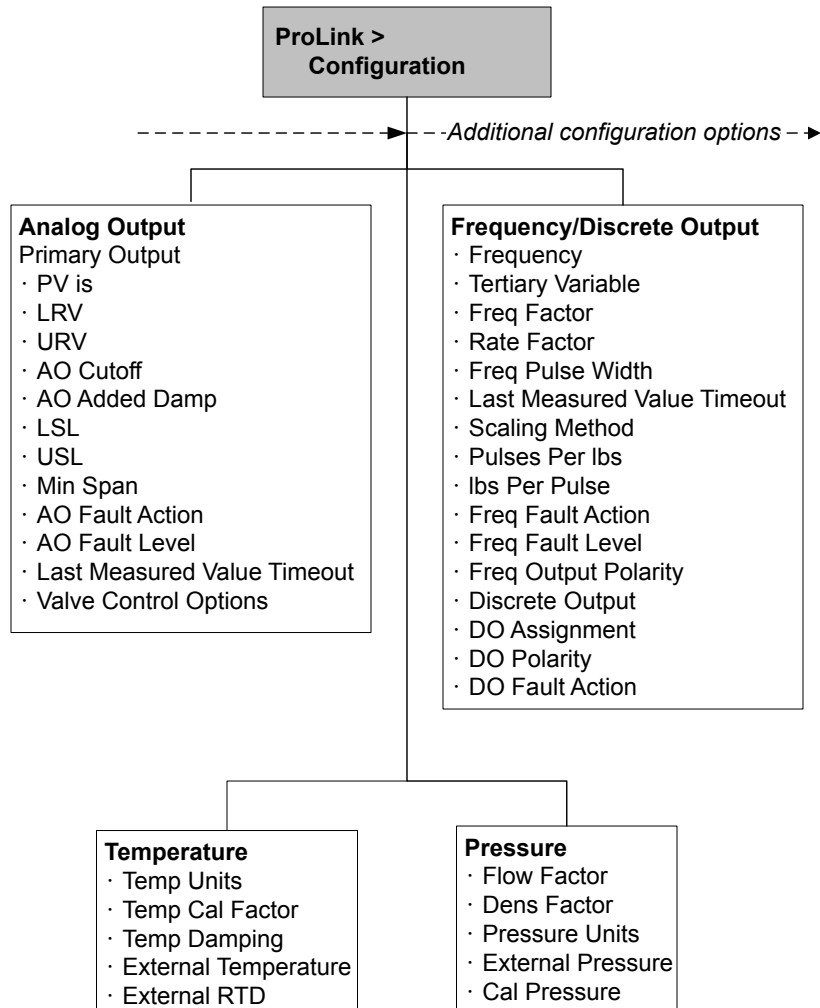


Figure B-13: Configuration menu (continued)

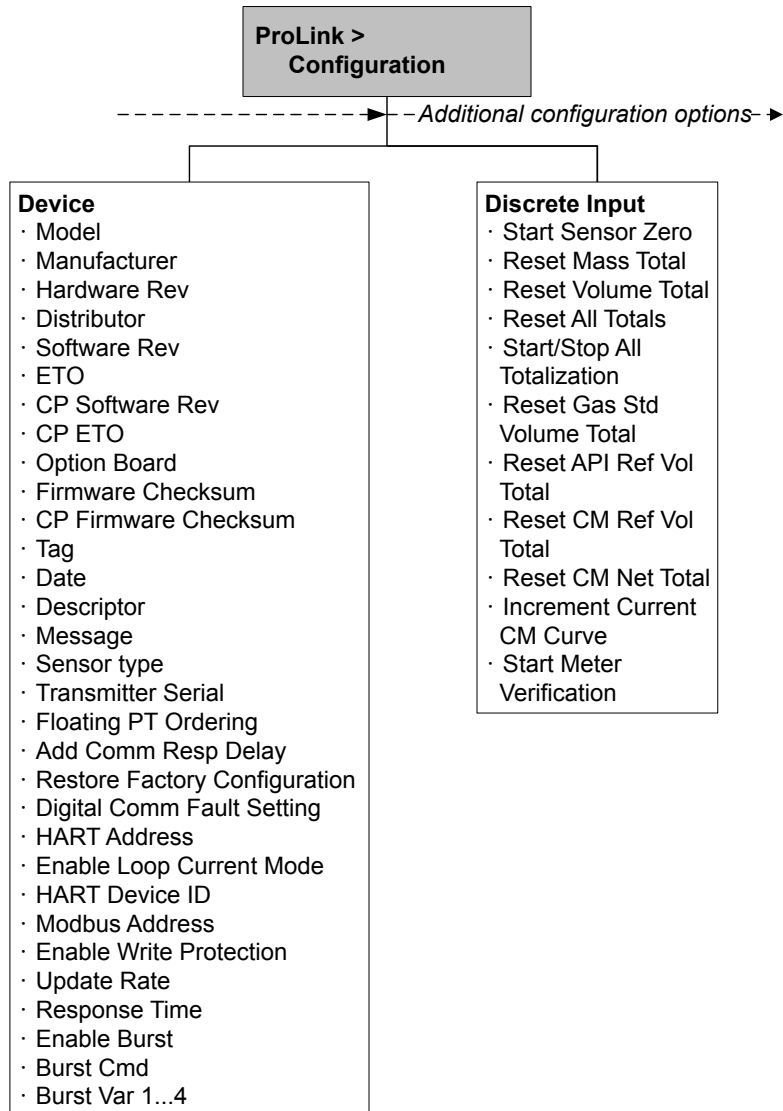


Figure B-14: Configuration menu (continued)

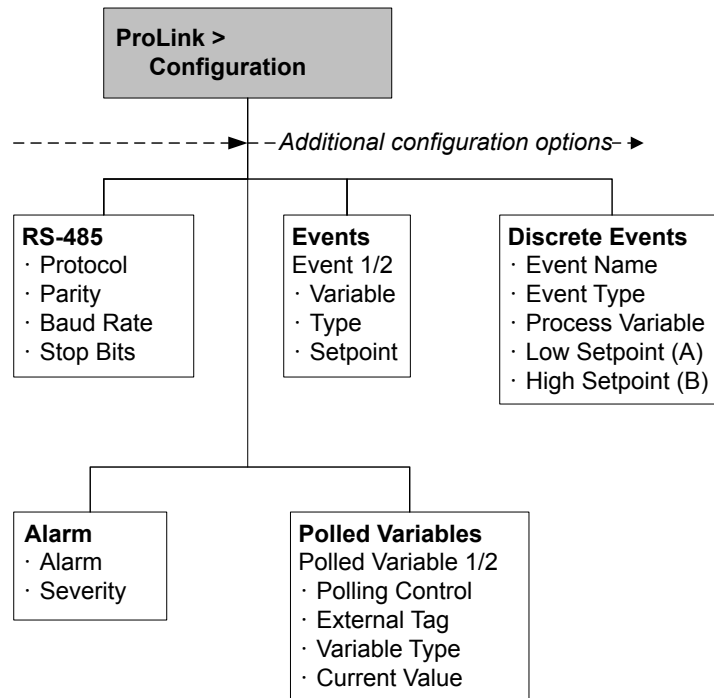


Figure B-15: Configuration menu (continued)

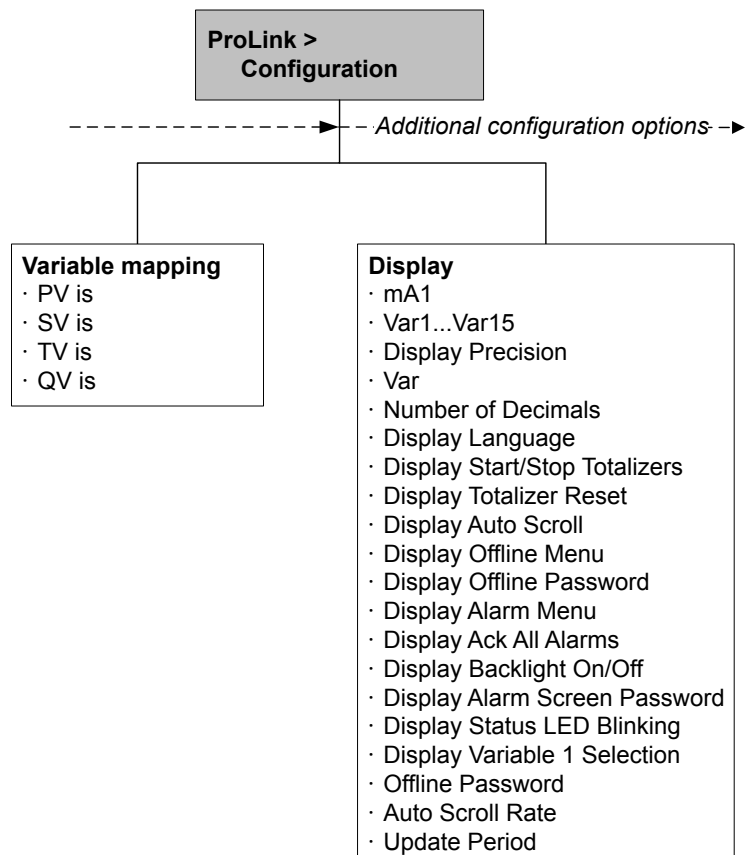


Figure B-16: Configuration menu (continued)

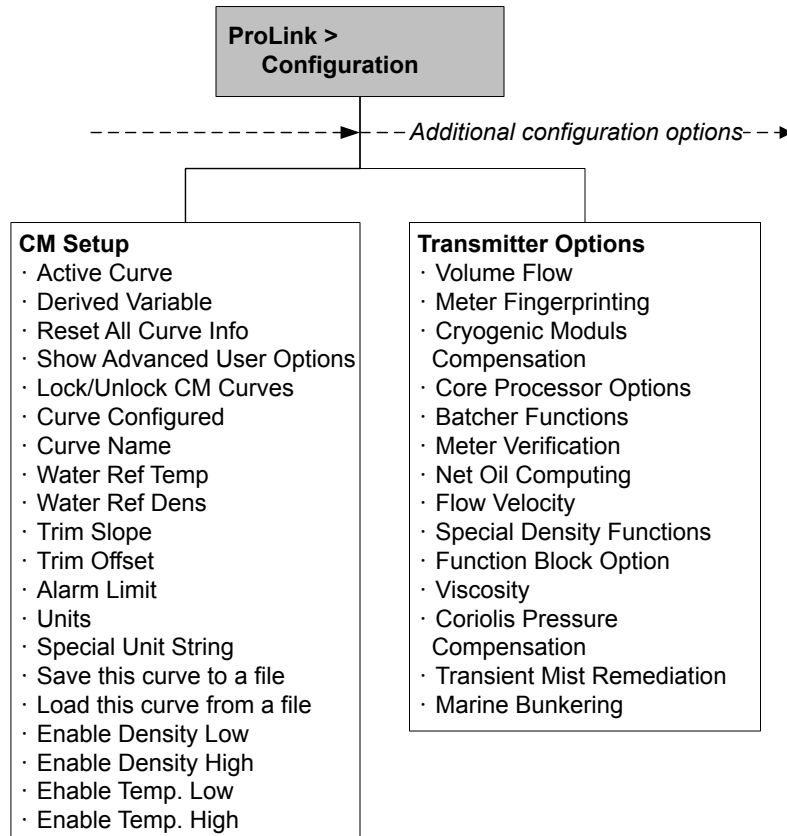


Figure B-17: Configuration menu (continued)

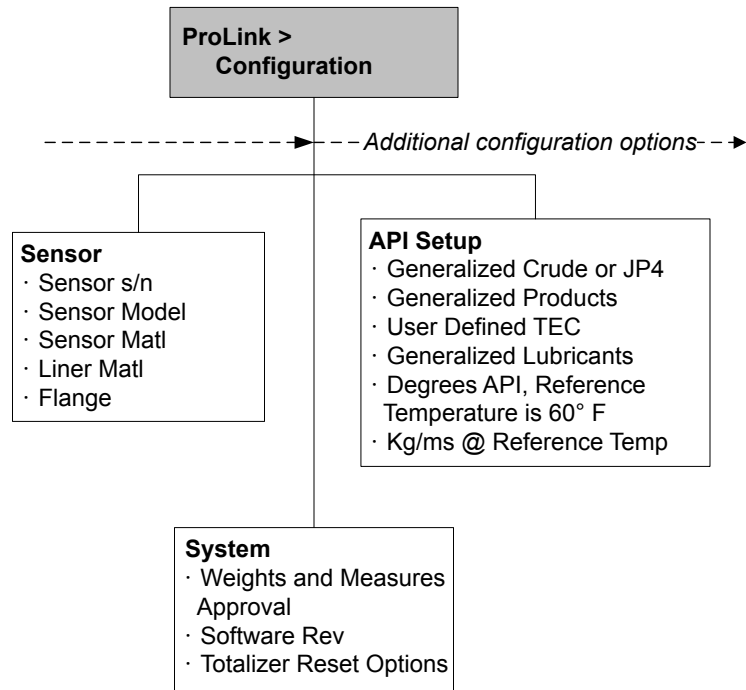
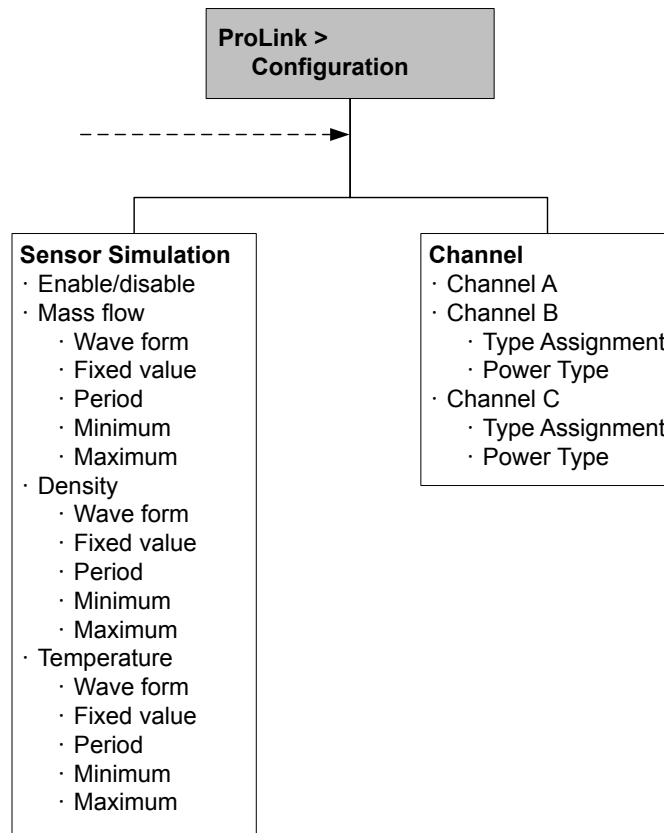


Figure B-18: Configuration menu (continued)



Appendix C

Using ProLink III with the transmitter

Topics covered in this appendix:

- [Basic information about ProLink III](#)
- [Connect with ProLink III](#)
- [Menu maps for ProLink III](#)

C.1 Basic information about ProLink III

ProLink III is a configuration and service tool available from Micro Motion. It runs on a Windows platform and provides complete access to transmitter functions and data.

ProLink III requirements

To install ProLink III, you must have:

- The ProLink III installation media
- The ProLink III installation kit for your connection type

To obtain ProLink III and the appropriate installation kit, contact Micro Motion.

ProLink III documentation

Most of the instructions in this manual assume that you are already familiar with ProLink III or that you have a general familiarity with Windows programs. If you need more information than this manual provides, see the ProLink III manual (*ProLink® III Configuration and Service Tool for Micro Motion® Transmitters: User Manual*).

In most ProLink III installations, the manual is installed with the ProLink III program. Additionally, the ProLink III manual is available on the Micro Motion documentation CD or the Micro Motion web site (www.micromotion.com).

ProLink III features and functions

ProLink III offers complete transmitter configuration and operation functions. ProLink III also offers a number of additional features and functions, including:

- The ability to save the transmitter configuration set to a file on the PC, and reload it or propagate it to other transmitters
- The ability to log specific types of data to a file on the PC
- The ability to view performance trends for various types of data on the PC
- The ability to connect to and view information for more than one device
- A guided connection wizard

These features are documented in the ProLink III manual. They are not documented in the current manual.

ProLink III messages

As you use ProLink III with a Micro Motion transmitter, you will see a number of messages and notes. This manual does not document all of these messages and notes.

Important

The user is responsible for responding to messages and notes and complying with all safety messages.

C.2 Connect with ProLink III

A connection from ProLink III to your transmitter allows you to read process data, configure the transmitter, and perform maintenance and troubleshooting tasks.

C.2.1 ProLink III connection types

Different connection types are available for connecting from ProLink III to the transmitter. Choose the connection type appropriate to your network and the tasks you intend to perform.

The transmitter supports the following ProLink III connection types:

- Service port connections
- HART/Bell 202 connections
- HART/RS-485 connections
- Modbus/RS-485 7-bit connections (Modbus ASCII)
- Modbus/RS-485 8-bit connections (Modbus RTU)

When selecting a connection type, consider the following:

- Service port connections use standard connection parameters that are already defined in ProLink III, and therefore you do not have to configure them.
- HART/Bell 202 connections use standard HART connection parameters that are already defined in ProLink III. The only parameter you must configure is the transmitter address.
- Some connection types require opening the wiring compartment or the power supply compartment. These connection types should be used only for temporary connections, and may require extra safety precautions.
- Modbus connections, including service port connections, are typically faster than HART connections.
- When you are using a HART connection, ProLink III will not allow you to open more than one window at a time. This is done to manage network traffic and optimize speed.
- You cannot make concurrent connections if the connections use the same terminals. You can make concurrent connections if the connections use different terminals.

C.2.2 Make a service port connection

CAUTION!

If the transmitter is in a hazardous area, do not use a service port connection. Service port connections require opening the wiring compartment, and opening the wiring compartment while the transmitter is powered up could cause an explosion. To connect to the transmitter in a hazardous environment, use a connection method that does not require removing the transmitter housing cover.

Prerequisites

- ProLink III installed and licensed on your PC
- One of the following:
 - RS-232 to RS-485 signal converter
 - USB to RS-485 signal converter
- An available serial port or USB port
- Adapters as required (for example, 9-pin to 25-pin)

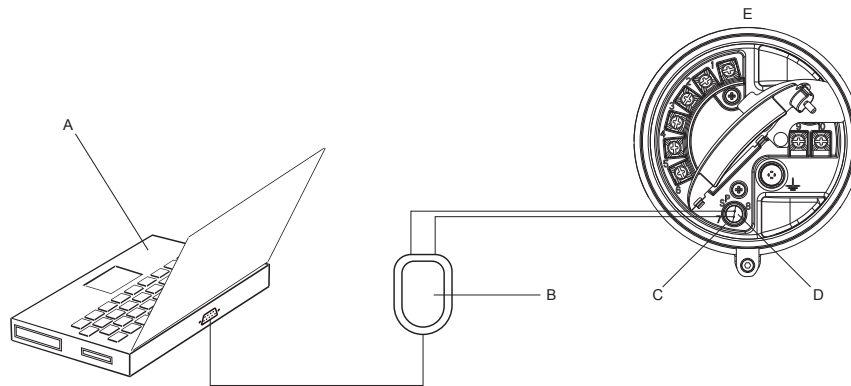
Procedure

1. Attach the signal converter to the serial port or USB port on your PC.
2. Access the service port terminals:
 - a. Remove the transmitter end-cap to access the wiring compartment.
 - b. Loosen the screw on the Warning flap and open the power supply compartment.
3. Connect the leads from the signal converter to the service port, terminals 7 (RS-485/A) and 8 (RS-485/B).

Tip

Usually, but not always, the black lead is RS-485/A and the red lead is RS-485/B.

Figure C-1: Connection to service port



- A. PC
- B. Signal converter
- C. Service port terminal 7 (RS-485/A)
- D. Service port terminal 8 (RS-485/B)
- E. Transmitter, with wiring compartment and power supply compartment opened

Note

This figure shows a serial port connection. USB connections are also supported.

4. Start ProLink III.
5. Choose Connect to Physical Device.
6. Set Protocol to Service Port.

Tip

Service port connections use standard connection parameters and a standard address. You do not need to configure them here.

7. Set the PC Port value to the PC COM port that you are using for this connection.
8. Click Connect.

Need help? If an error message appears:

- Switch the leads and try again.
- Ensure that you have specified the correct COM port.
- Check the physical connection between the PC and the transmitter.

C.2.3 Make a HART/Bell 202 connection

You can connect directly to the mA terminals on the transmitter, to any point in a local HART loop, or to any point in a HART multidrop network.

⚠ CAUTION!

If the transmitter is in a hazardous area, do not connect directly to the transmitter terminals. Connecting directly to the transmitter terminals requires opening the wiring compartment, and opening the wiring compartment while the transmitter is powered up could cause an explosion. To connect to the transmitter in a hazardous environment, use a connection method that does not require opening the wiring compartment.

⚠ CAUTION!

If you connect directly to the mA terminals, the transmitter's mA output may be affected. If you are using the mA output for flow control, set devices for manual control before connecting directly to the mA terminals.

Prerequisites

- ProLink III installed and licensed on your PC
- One of the following:
 - RS-232 to Bell 202 signal converter
 - USB to Bell 202 signal converter
- An available serial port or USB port
- Adapters as required (for example, 9-pin to 25-pin)

Procedure

1. Attach the signal converter to the serial port or USB port on your PC.
2. To connect directly to the transmitter terminals:
 - a. Remove the transmitter end-cap to access the wiring compartment.
 - b. Connect the leads from the signal converter to terminals 1 and 2.

Tip

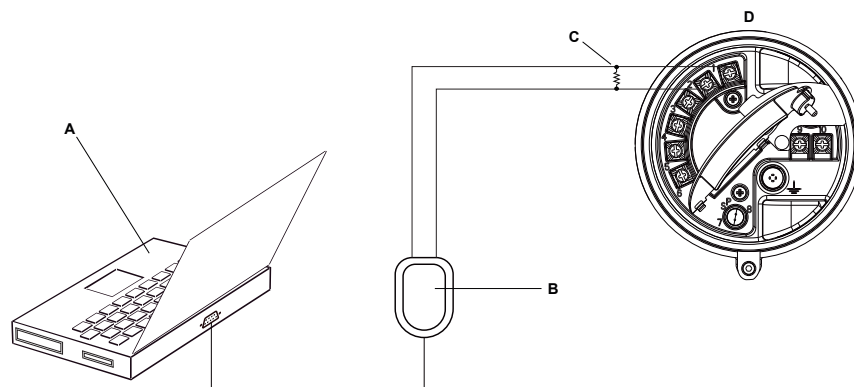
HART connections are not polarity-sensitive. It does not matter which lead you attach to which terminal.

- c. Add resistance as necessary.

Important

HART/Bell 202 connections require a voltage drop of 1 VDC. To achieve this, add resistance of 250–600 Ω to the connection.

Figure C-2: Connection to transmitter terminals



- A. PC
- B. Signal converter
- C. 250–600 Ω resistance
- D. Transmitter, with wiring compartment and power supply compartment opened

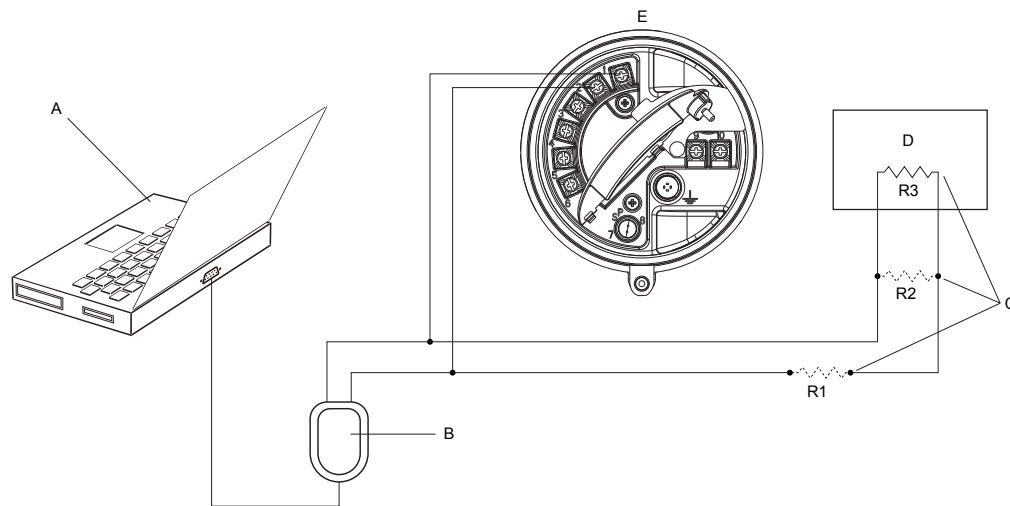
Note

This figure shows a serial port connection. USB connections are also supported.

3. To connect from a point in the local HART loop:
 - a. Attach the leads from the signal converter to any point in the loop.
 - b. Add resistance as necessary.

Important

HART/Bell 202 connections require a voltage drop of 1 VDC. To achieve this, add resistance of 250–600 Ω to the connection.

Figure C-3: Connection over local loop

- A. PC
- B. Signal converter
- C. Any combination of resistors R1, R2, and R3 as necessary to meet HART communication resistance requirements
- D. DCS or PLC
- E. Transmitter, with wiring compartment and power supply compartment opened

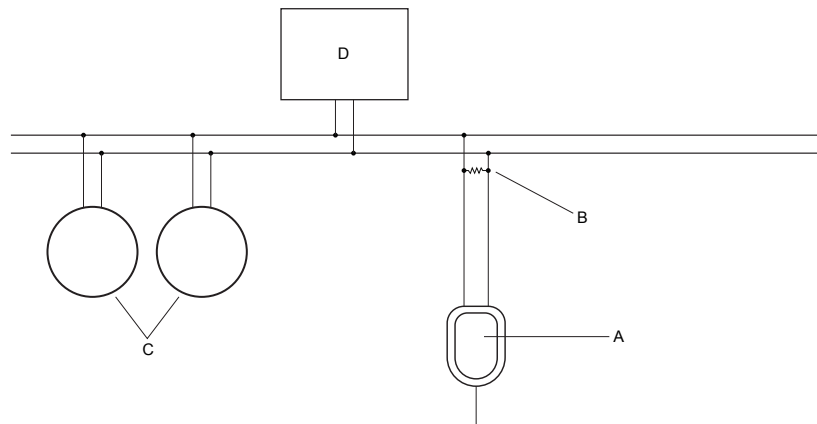
Note

This figure shows a serial port connection. USB connections are also supported.

4. To connect over a HART multidrop network:
 - a. Attach the leads from the signal converter to any point on the network.
 - b. Add resistance as necessary.

Important

HART/Bell 202 connections require a voltage drop of 1 VDC. To achieve this, add resistance of 250–600 Ω to the connection.

Figure C-4: Connection over multidrop network

- A. Signal converter
- B. 250–600 Ω resistance
- C. Devices on the network
- D. Master device

5. Start ProLink III.
6. Choose Connect to Physical Device.
7. Set Protocol to HART Bell 202.

Tip

HART/Bell 202 connections use standard connection parameters. You do not need to configure them here.

8. If you are using a USB signal converter, enable Toggle RTS.
9. Set Address/Tag to the HART polling address configured in the transmitter.

Tips

- If this is the first time you are connecting to the transmitter, use the default address: 0.
- If you are not in a HART multidrop environment, the HART polling address is typically left at the default value.
- If you are unsure of the transmitter's address, click Poll. The program will search the network and return a list of the transmitters that it detects.

10. Set the PC Port value to the PC COM port that you are using for this connection.
11. Set Master as appropriate.

Option	Description
Secondary	Use this setting if another HART host such as a DCS is on the network.

Option	Description
Primary	Use this setting if no other host is on the network. The Field Communicator is not a host.

12. Click Connect.

Need help? If an error message appears:

- Verify the HART address of the transmitter.
- Ensure that you have specified the correct COM port.
- Check the physical connection between the PC and the transmitter.
- Increase or decrease resistance.
- Ensure that there is no conflict with another HART master.

C.2.4 Make a HART/RS-485 connection

You can connect directly to the RS-485 terminals on the transmitter or to any point on the network.

CAUTION!

If the transmitter is in a hazardous area, do not connect directly to the transmitter terminals. Connecting directly to the transmitter terminals requires opening the wiring compartment, and opening the wiring compartment while the transmitter is powered up could cause an explosion. To connect to the transmitter in a hazardous environment, use a connection method that does not require opening the wiring compartment.

Prerequisites

- ProLink III installed and licensed on your PC
- One of the following:
 - RS-232 to RS-485 signal converter
 - USB to RS-485 signal converter
- An available serial port or USB port
- Adapters as required (for example, 9-pin to 25-pin)

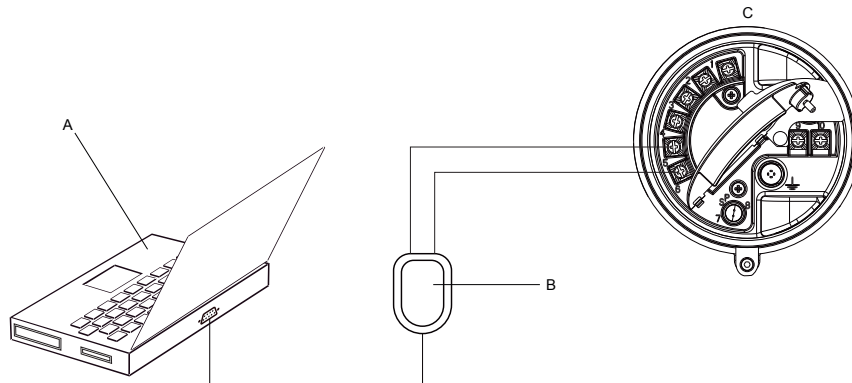
Procedure

1. Attach the signal converter to the serial port or USB port on your PC.
2. To connect directly to the transmitter terminals:
 - a. Remove the transmitter end-cap to access the wiring compartment.
 - b. Connect the leads from the signal converter to terminals 5 (RS-485/A) and 6 (RS-485/B).

Tip

HART connections are not polarity-sensitive. It does not matter which lead you attach to which terminal.

Figure C-5: Connection to transmitter terminals

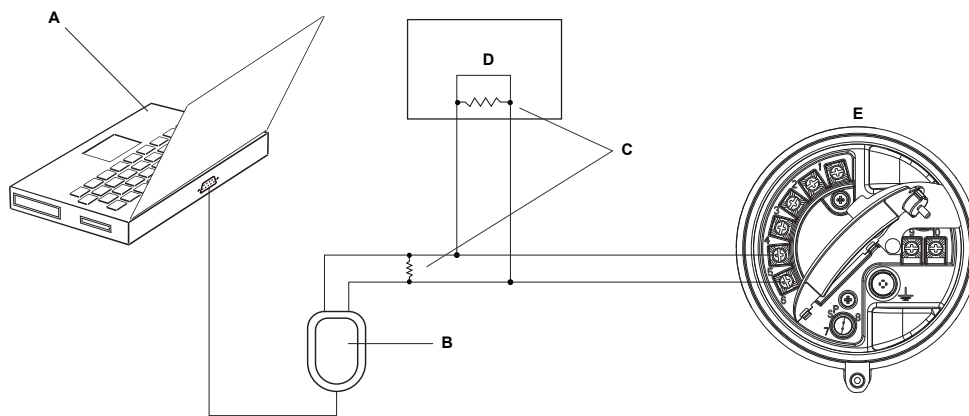


- A. PC
- B. Signal converter
- C. Transmitter, with wiring compartment and power supply compartment opened

Note

This figure shows a serial port connection. USB connections are also supported.

3. To connect over the RS-485 network:
 - a. Attach the leads from the signal converter to any point on the network.
 - b. Add resistance as necessary.

Figure C-6: Connection over network

- A. PC
- B. Adapter, if necessary
- C. Signal converter
- D. 120- Ω , 1/2-watt resistors at both ends of the segment, if necessary
- E. DCS or PLC
- F. Transmitter, with wiring compartment and power supply compartment opened

Note

This figure shows a serial port connection. USB connections are also supported.

4. Start ProLink III.
5. Choose Connect to Physical Device.
6. Set the connection parameters to the values configured in the transmitter.

If your transmitter has not been configured, use the default values shown here.

Table C-1: Default HART/RS-485 connection parameters

Parameter	Default values
Protocol	HART
Baud	1200
Parity	Odd
Stop Bits	1
Address	0

Tip

If you do not know the transmitter's RS-485 communication settings, you can connect through the service port, which always uses default settings, or use another communications tool to view or change the settings.

7. Set the PC Port value to the PC COM port that you are using for this connection.

8. Set Master as appropriate.

Option	Description
Secondary	Use this setting if another HART host such as a DCS is on the network.
Primary	Use this setting if no other host is on the network. The Field Communicator is not a host.

9. Click Connect.

Need help? If an error message appears:

- Verify the HART address of the transmitter.
- Ensure that you have specified the correct COM port.
- Check the physical connection between the PC and the transmitter.
- Ensure that there is no conflict with another HART master.
- For long-distance communication, or if noise from an external source interferes with the signal, install 120-Ω ½-W terminating resistors in parallel with the output at both ends of the communication segment.

C.2.5 Make a Modbus/RS-485 connection

You can connect directly to the RS-485 terminals on the transmitter or to any point on the network.

CAUTION!

If the transmitter is in a hazardous area, do not connect directly to the transmitter terminals. Connecting directly to the transmitter terminals requires opening the wiring compartment, and opening the wiring compartment while the transmitter is powered up could cause an explosion. To connect to the transmitter in a hazardous environment, use a connection method that does not require opening the wiring compartment.

Prerequisites

- ProLink III installed and licensed on your PC
- One of the following:
 - RS-232 to RS-485 signal converter
 - USB to RS-485 signal converter
- An available serial port or USB port
- Adapters as required (for example, 9-pin to 25-pin)

Procedure

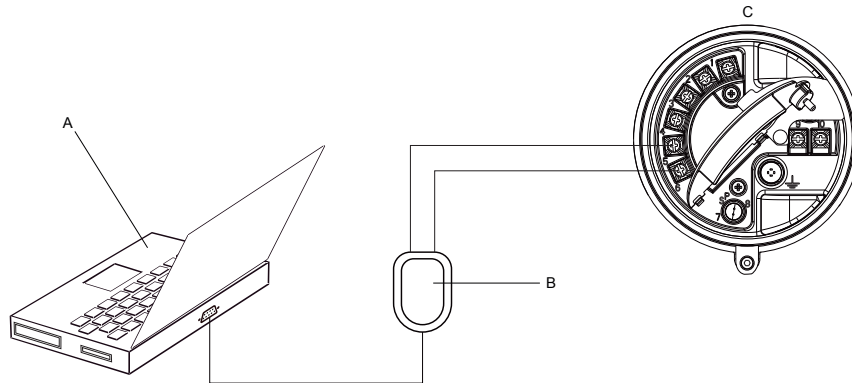
1. Attach the signal converter to the serial port or USB port on your PC.
2. To connect directly to the transmitter terminals:
 - a. Remove the transmitter end-cap to access the wiring compartment.

- b. Connect the leads from the signal converter to terminals 5 (RS-485/A) and 6 (RS-485/B).

Tip

Usually, but not always, the black lead is RS-485/A and the red lead is RS-485/B.

Figure C-7: Connection to transmitter terminals

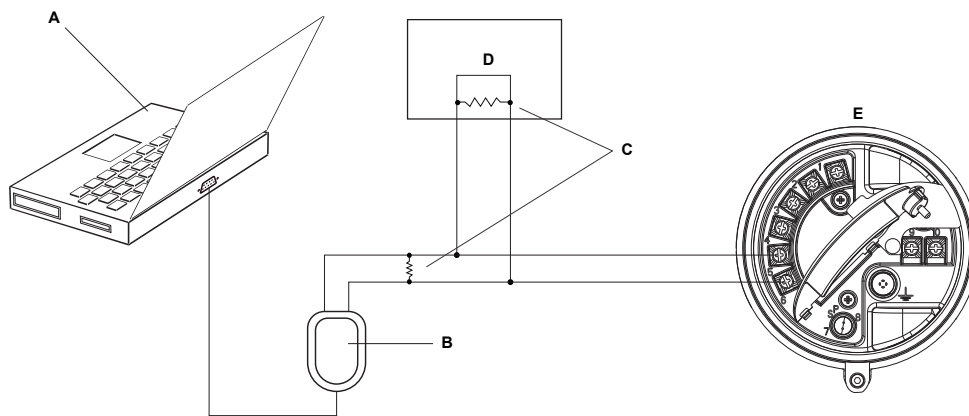


- A. PC
- B. Signal converter
- C. Transmitter, with wiring compartment and power supply compartment opened

Note

This figure shows a serial port connection. USB connections are also supported.

3. To connect over the RS-485 network:
 - a. Attach the leads from the signal converter to any point on the network.
 - b. Add resistance as necessary.

Figure C-8: Connection over network

- A. PC
- B. Signal converter
- C. 120- Ω , 1/2-watt resistors at both ends of the segment, if necessary
- D. DCS or PLC
- E. Transmitter, with wiring compartment and power supply compartment opened

Note

This figure shows a serial port connection. USB connections are also supported.

4. Start ProLink III.
5. Choose Connect to Physical Device.
6. Set the connection parameters to the values configured in the transmitter.
If your transmitter has not been configured, use the default values shown here.

Table C-2: Default Modbus/RS-485 connection parameters

Parameter	Default value
Protocol	Modbus RTU
Baud	9600
Parity	Odd
Stop Bits	1
Address	1

Tip

If you do not know the transmitter's RS-485 communication settings, you can connect through the service port, which always uses default settings, or use another communications tool to view or change the settings.

7. Set the PC Port value to the PC COM port that you are using for this connection.
8. Click Connect.

Need help? If an error message appears:

- Verify the Modbus address of the transmitter.
- Ensure that you have specified the correct COM port.
- Check the physical connection between the PC and the transmitter.
- Increase or decrease resistance.
- For long-distance communication, or if noise from an external source interferes with the signal, install 120- Ω 1/2-W terminating resistors in parallel with the output at both ends of the communication segment.
- Ensure that there is no concurrent Modbus communication to the transmitter.

C.3 Menu maps for ProLink III

Figure C-9: Device Tools: Main

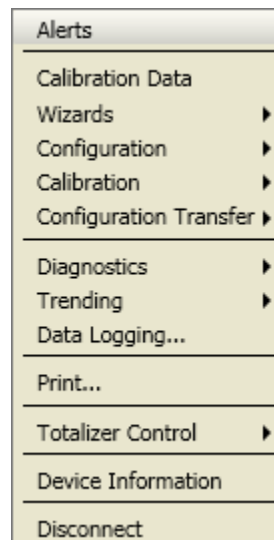


Figure C-10: Device Tools: Configuration (with Weights & Measures)

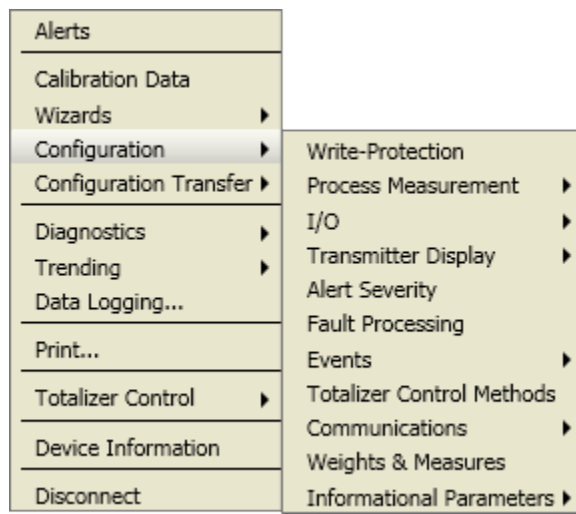


Figure C-11: Configuration: Process Measurement (with Concentration Measurement)

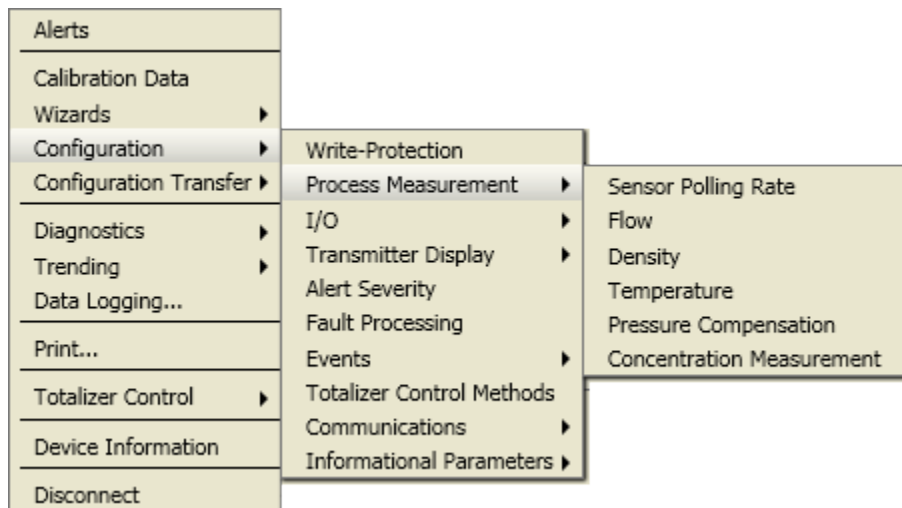


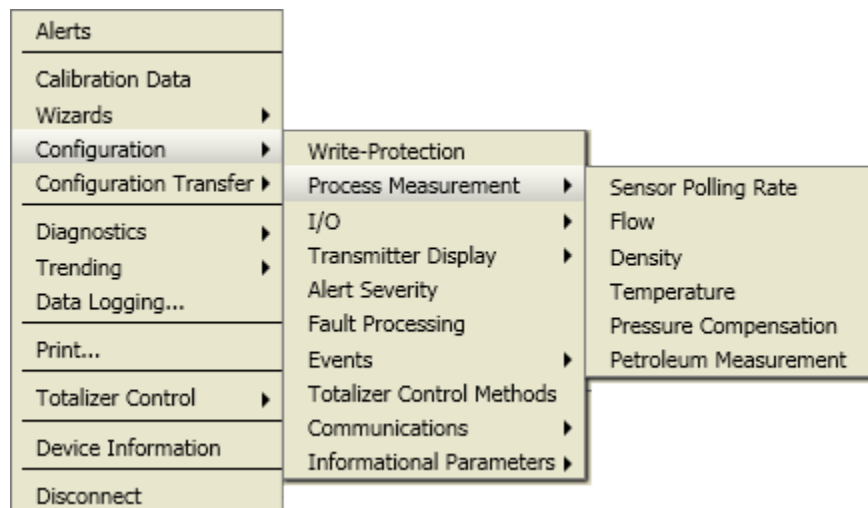
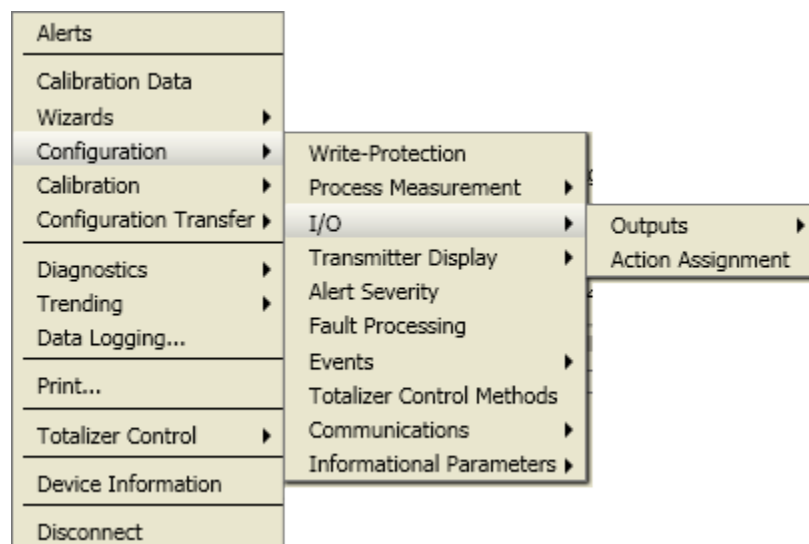
Figure C-12: Configuration: Process Measurement (with Petroleum Measurement)**Figure C-13: Configuration: I/O**

Figure C-14: Configuration: Transmitter Display

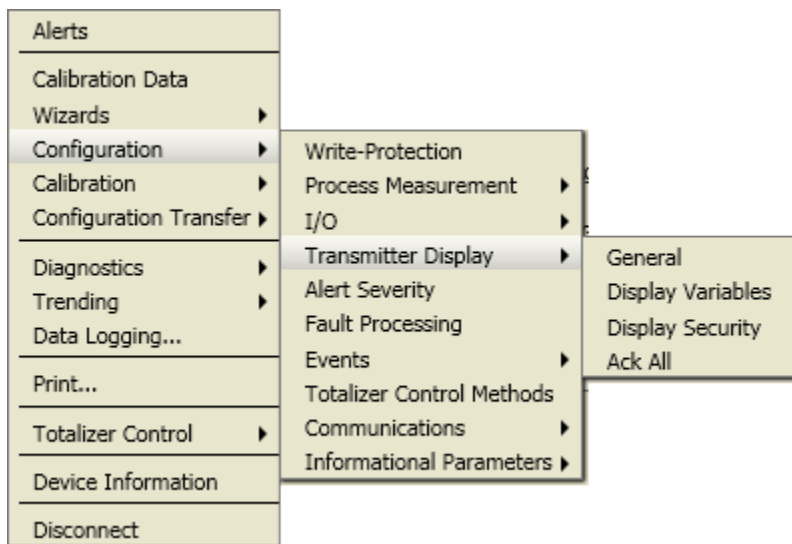


Figure C-15: Configuration: Events

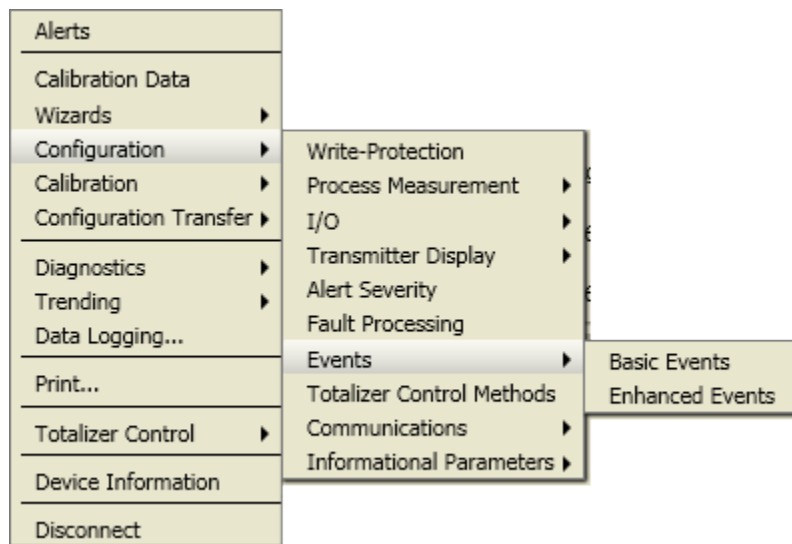


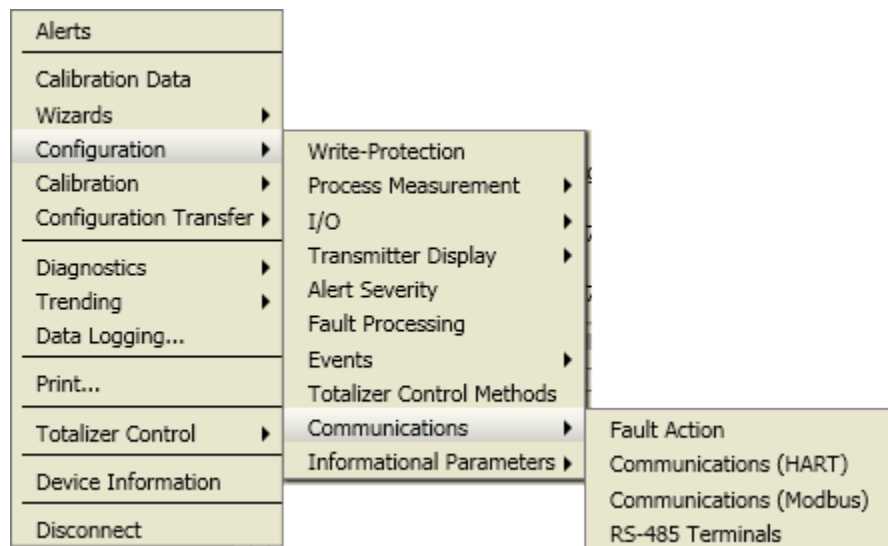
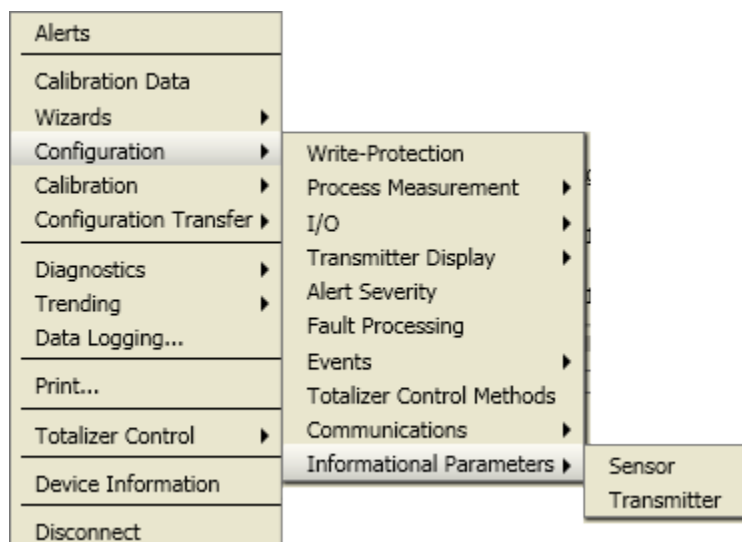
Figure C-16: Configuration: Communications**Figure C-17: Configuration: Informational Parameters**

Figure C-18: Device Tools: Calibration

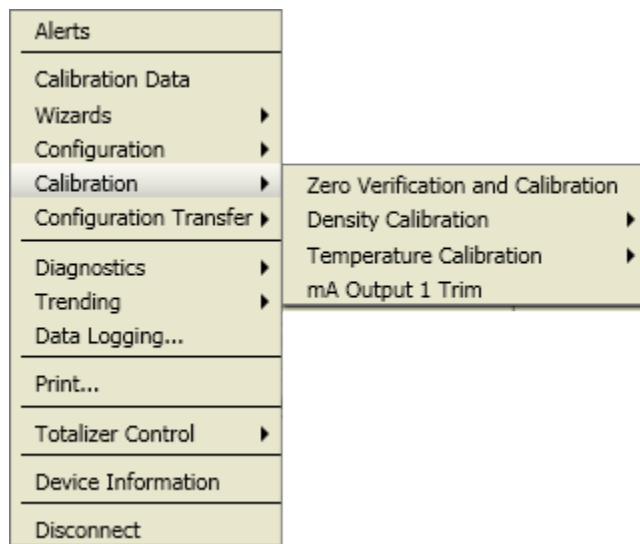


Figure C-19: Calibration: Density Calibration

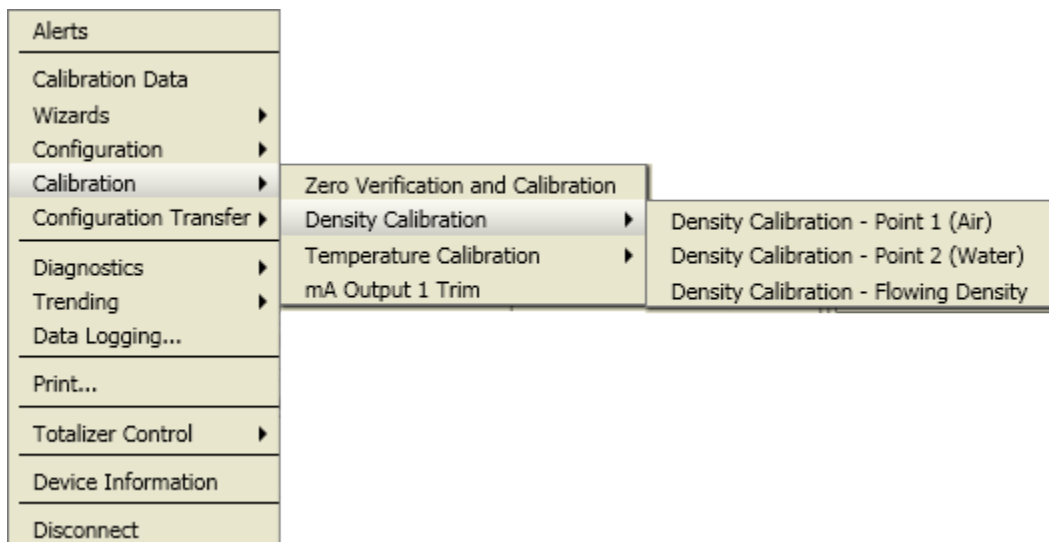


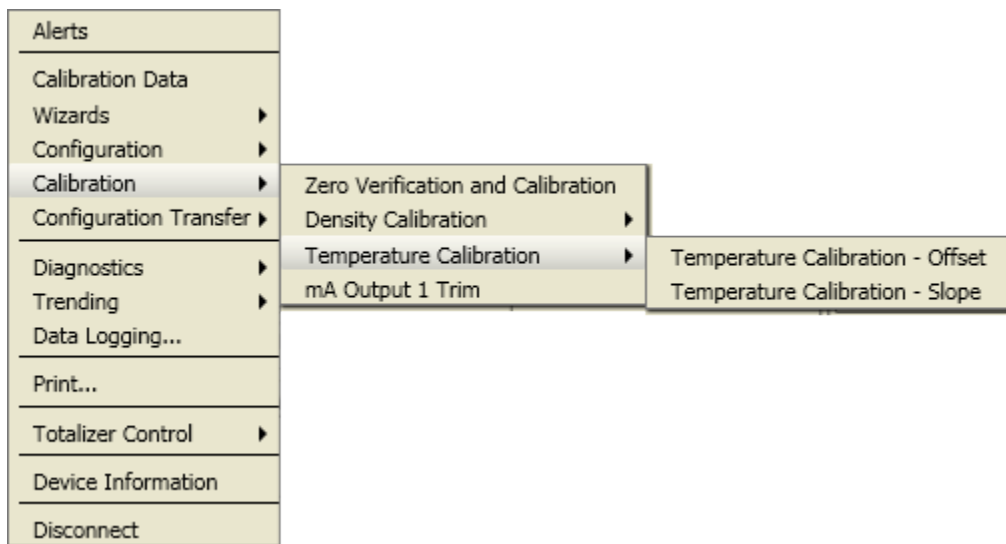
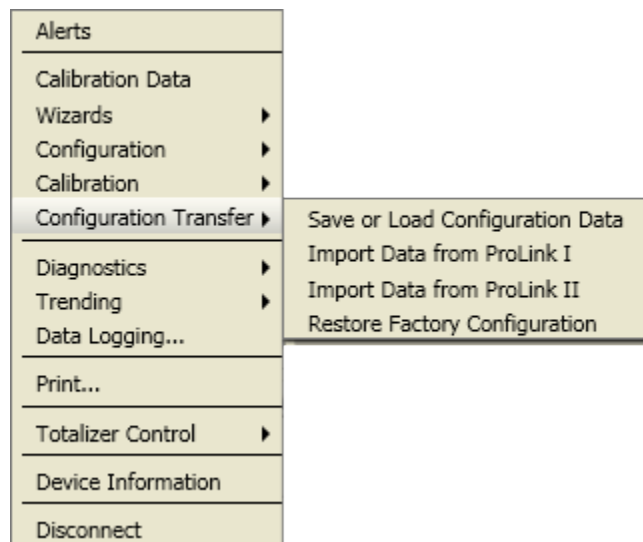
Figure C-20: Calibration: Temperature Calibration**Figure C-21: Device Tools: Configuration Transfer**

Figure C-22: Diagnostics: Testing

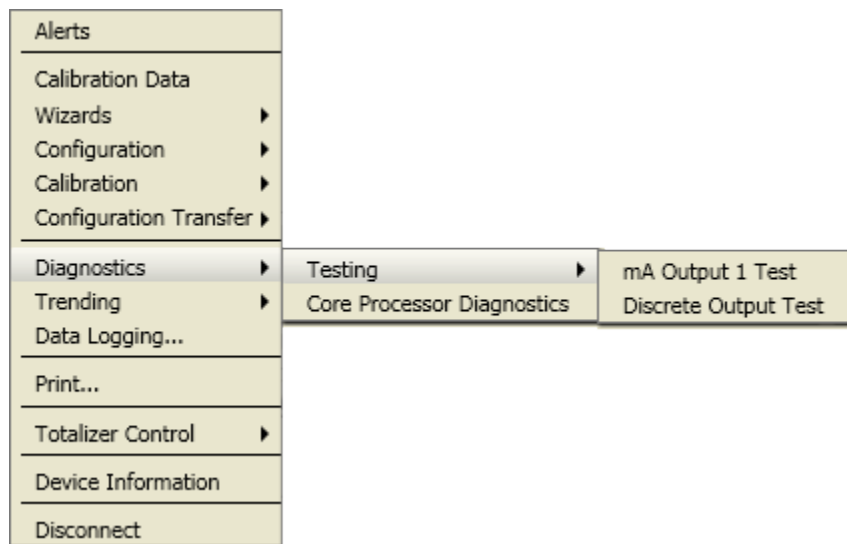


Figure C-23: Diagnostics: Meter Verification

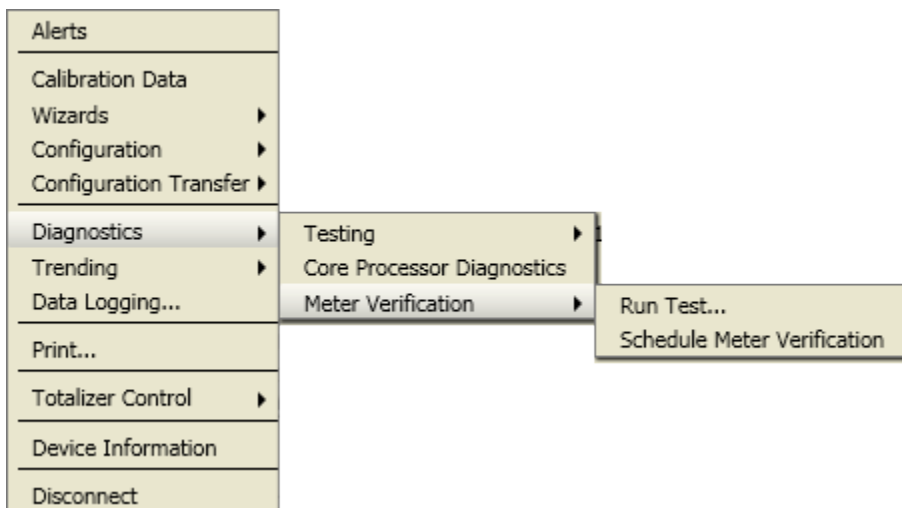
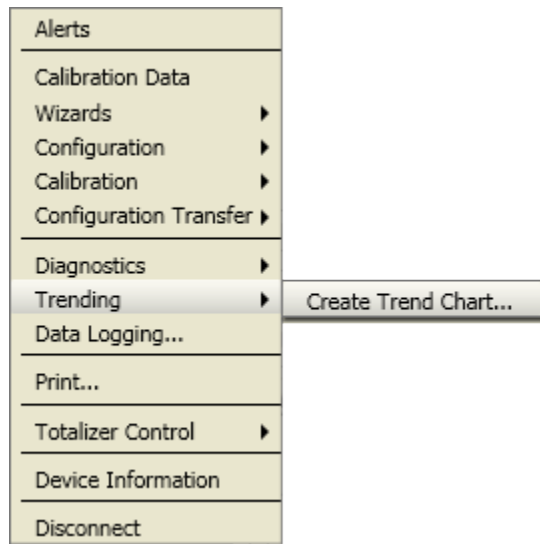


Figure C-24: Device Tools: Trending



Appendix D

Using the Field Communicator with the transmitter

Topics covered in this appendix:

- [Basic information about the Field Communicator](#)
- [Connect with the Field Communicator](#)
- [Menu maps for the Field Communicator](#)

D.1 Basic information about the Field Communicator

The Field Communicator is a handheld configuration and management tool that can be used with a variety of devices, including Micro Motion transmitters. It provides complete access to transmitter functions and data.

Field Communicator documentation

Most of the instructions in this manual assume that you are already familiar with the Field Communicator and can perform the following tasks:

- Turn on the Field Communicator
- Navigate the Field Communicator menus
- Establish communication with HART-compatible devices
- Send configuration data to the device
- Use the alpha keys to enter information

If you are unable to perform these tasks, consult the Field Communicator manual before attempting to use the Field Communicator. The Field Communicator manual is available on the Micro Motion documentation CD or the Micro Motion web site (www.micromotion.com).

Device descriptions (DDs)

In order for the Field Communicator to work with your device, the appropriate device description (DD) must be installed. The Model 2700 transmitter requires the following HART device description: .

To view the device descriptions that are installed on your Field Communicator:

1. At the HART application menu, press Utility > Available Device Descriptions.
2. Scroll the list of manufacturers and select Micro Motion, then scroll the list of installed device descriptions.

If Micro Motion is not listed, or you do not see the required device description, use the Field Communicator Easy Upgrade Utility to install the device description, or contact Micro Motion.

Field Communicator menus and messages

Many of the menus in this manual start with the On-Line menu. Ensure that you are able to navigate to the On-Line menu.

As you use the Field Communicator with a Micro Motion transmitter, you will see a number of messages and notes. This manual does not document all of these messages and notes.

Important

The user is responsible for responding to messages and notes and complying with all safety messages.

D.2 Connect with the Field Communicator

A connection from the Field Communicator to your transmitter allows you to read process data, configure the transmitter, and perform maintenance and troubleshooting tasks.

You can connect the Field Communicator to the mA terminals on the transmitter, to any point in a local HART loop, or to any point in a HART multidrop network.

CAUTION!

If the transmitter is in a hazardous area, do not connect the Field Communicator to the mA terminals on the transmitter. This connection requires opening the wiring compartment, and opening the wiring compartment in a hazardous area can cause an explosion.

Prerequisites

The following HART device description (DD) must be installed on the Field Communicator: .

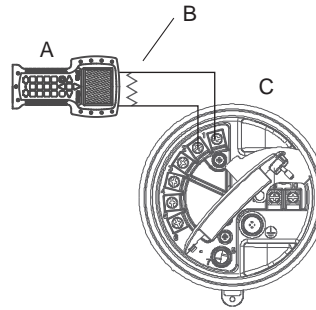
Procedure

1. To connect to the transmitter terminals:
 - a. Remove the cover from the wiring compartment.
 - b. Attach the leads from the Field Communicator to terminals 1 and 2 on the transmitter and add resistance as required.

The Field Communicator must be connected across a resistance of 250–600 Ω .

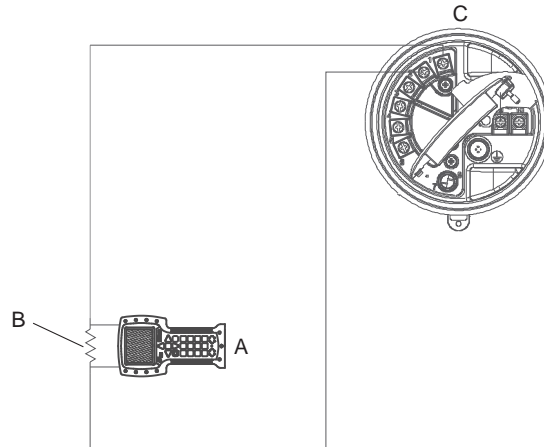
Tip

HART connections are not polarity-sensitive. It does not matter which lead you attach to which terminal.

Figure D-1: Field Communicator connection to transmitter terminals

- A. Field Communicator
- B. 250–600 Ω resistance
- C. Transmitter, with wiring compartment and power supply compartment opened

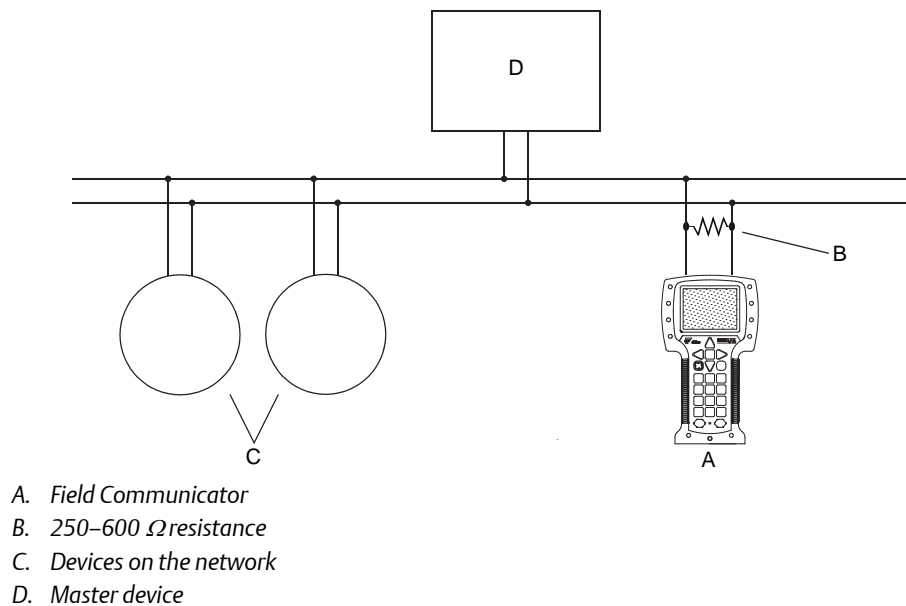
2. To connect to a point in the local HART loop, attach the leads from the Field Communicator to any point in the loop and add resistance as necessary. The Field Communicator must be connected across a resistance of 250–600 Ω .

Figure D-2: Field Communicator connection to local HART loop

- A. Field Communicator
- B. 250–600 Ω resistance
- C. Transmitter, with wiring compartment and power supply compartment opened

3. To connect to a point in the HART multidrop network, attach the leads from the Field Communicator to any point on the network..

Figure D-3: Field Communicator connection to multidrop network



4. Turn on the Field Communicator and wait until the main menu is displayed.
5. If you are connecting across a multidrop network:
 - a. Set the Field Communicator to poll.
The device returns all valid addresses.
 - b. Enter the HART address of the transmitter.
The default HART address is 0. However, in a multidrop network, the HART address has probably been set to a different, unique value.

Postrequisites

To navigate to the Online menu, choose HART Application > Online. Most configuration, maintenance, and troubleshooting tasks are performed from the Online menu.

Tip

You may see messages related to the DD or active alerts. Press the appropriate buttons to ignore the message and continue.

D.3 Menu maps for the Field Communicator

Figure D-4: On-Line menu

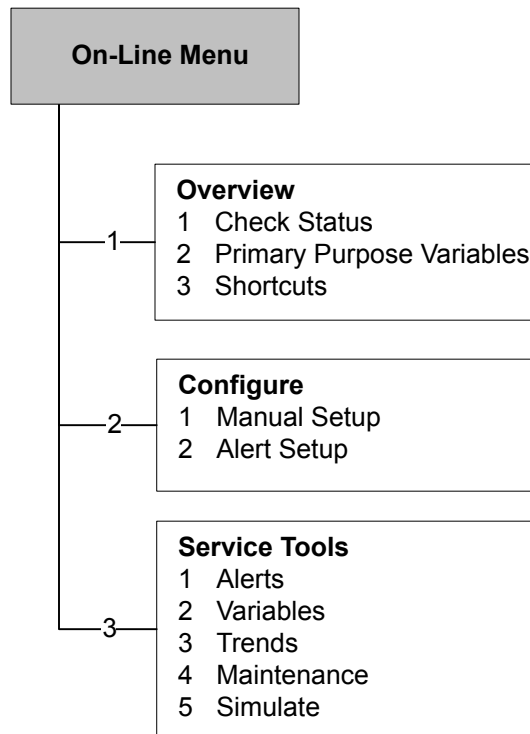


Figure D-5: Overview menu

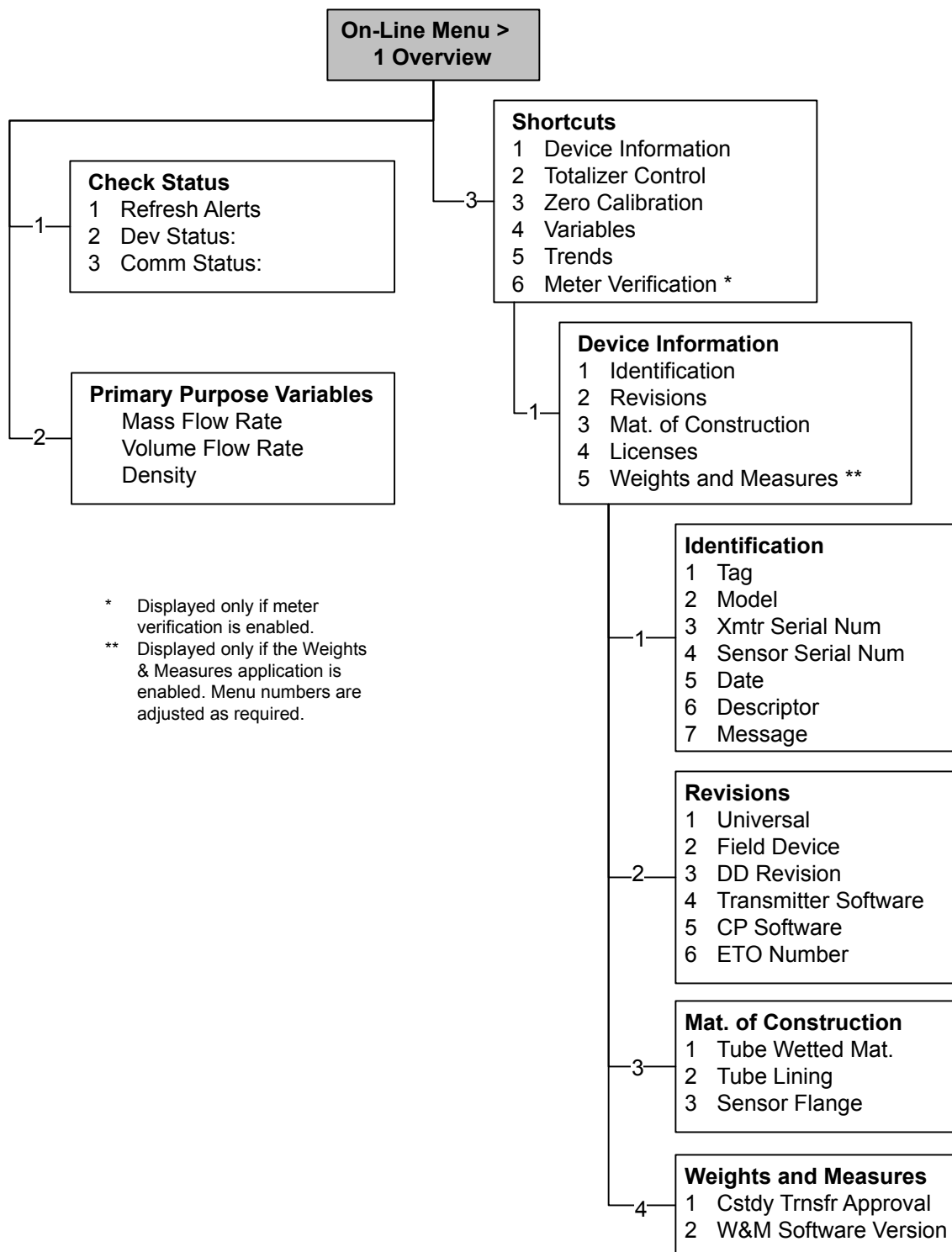


Figure D-6: Configure menu

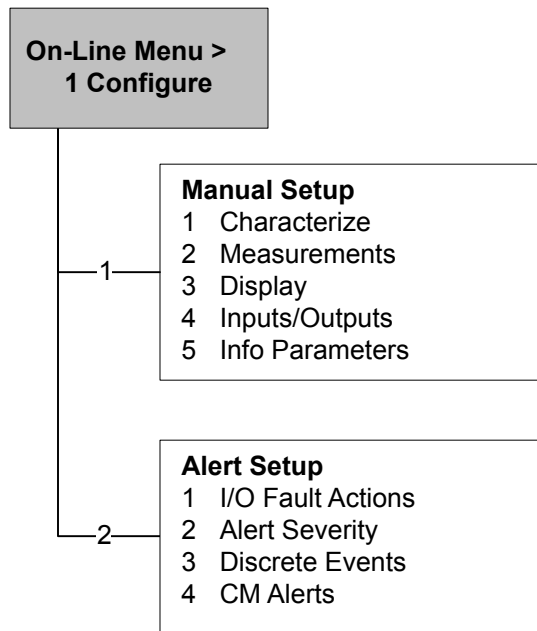


Figure D-7: Manual Setup menu

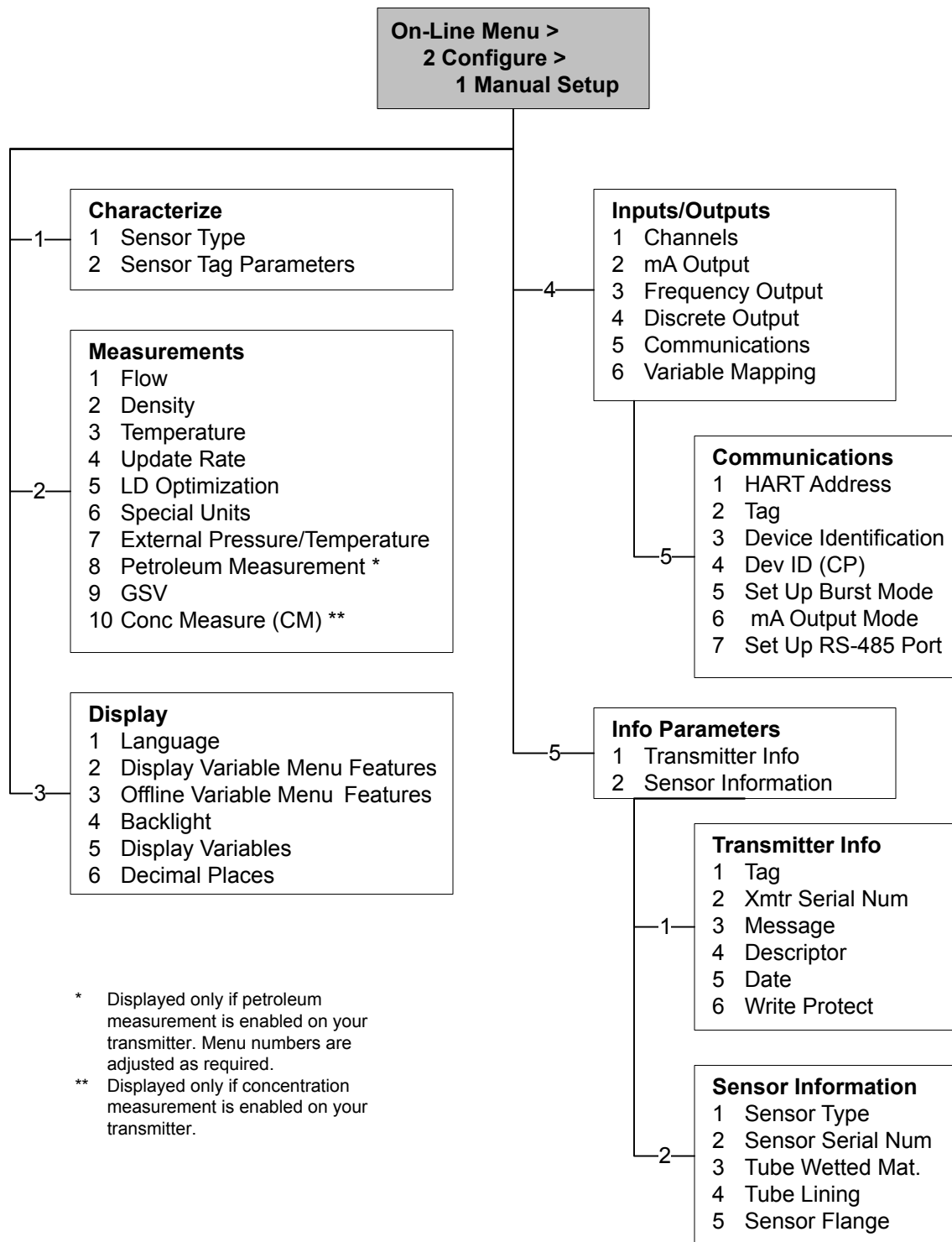


Figure D-8: Manual Setup menu: Characterize

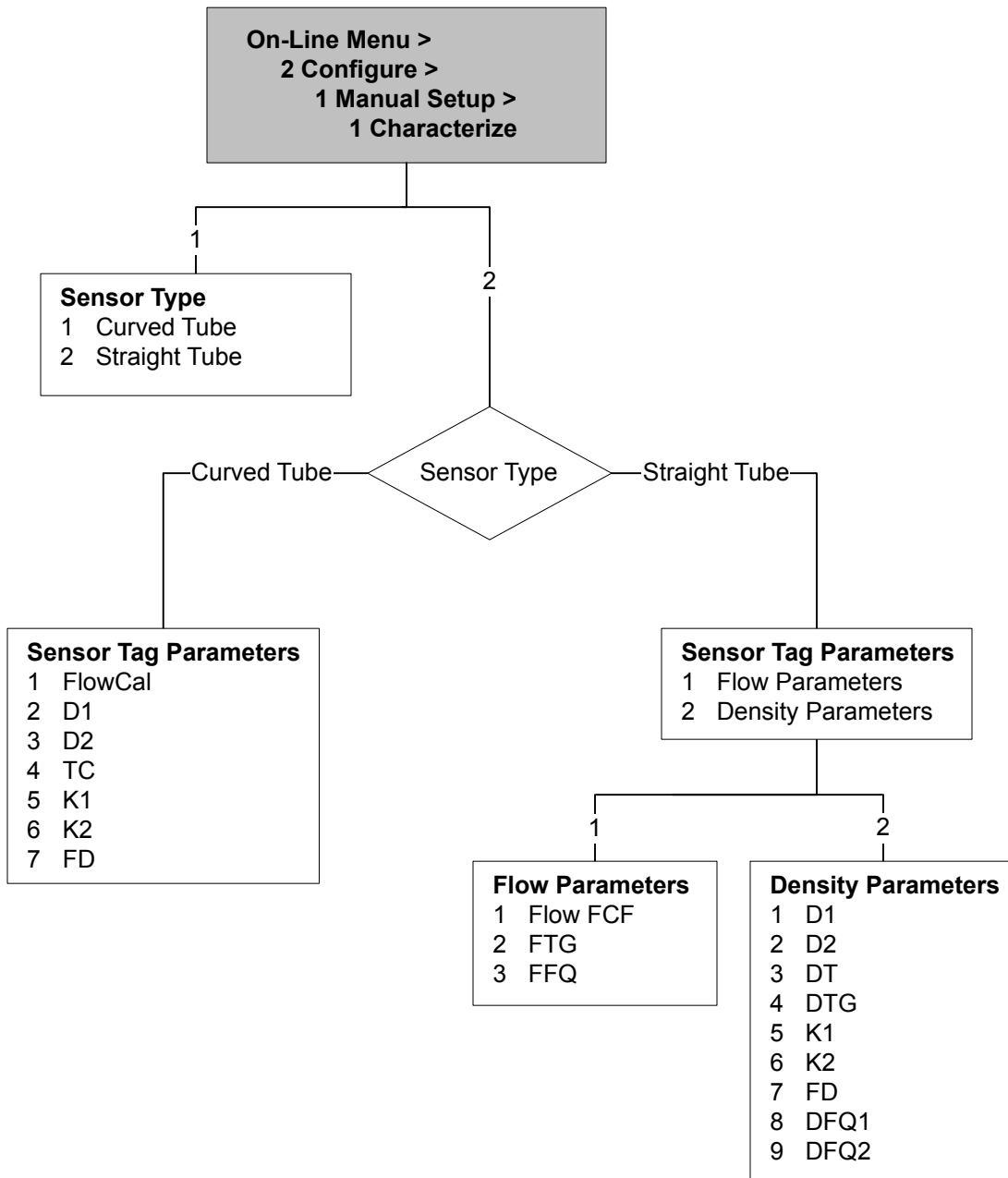
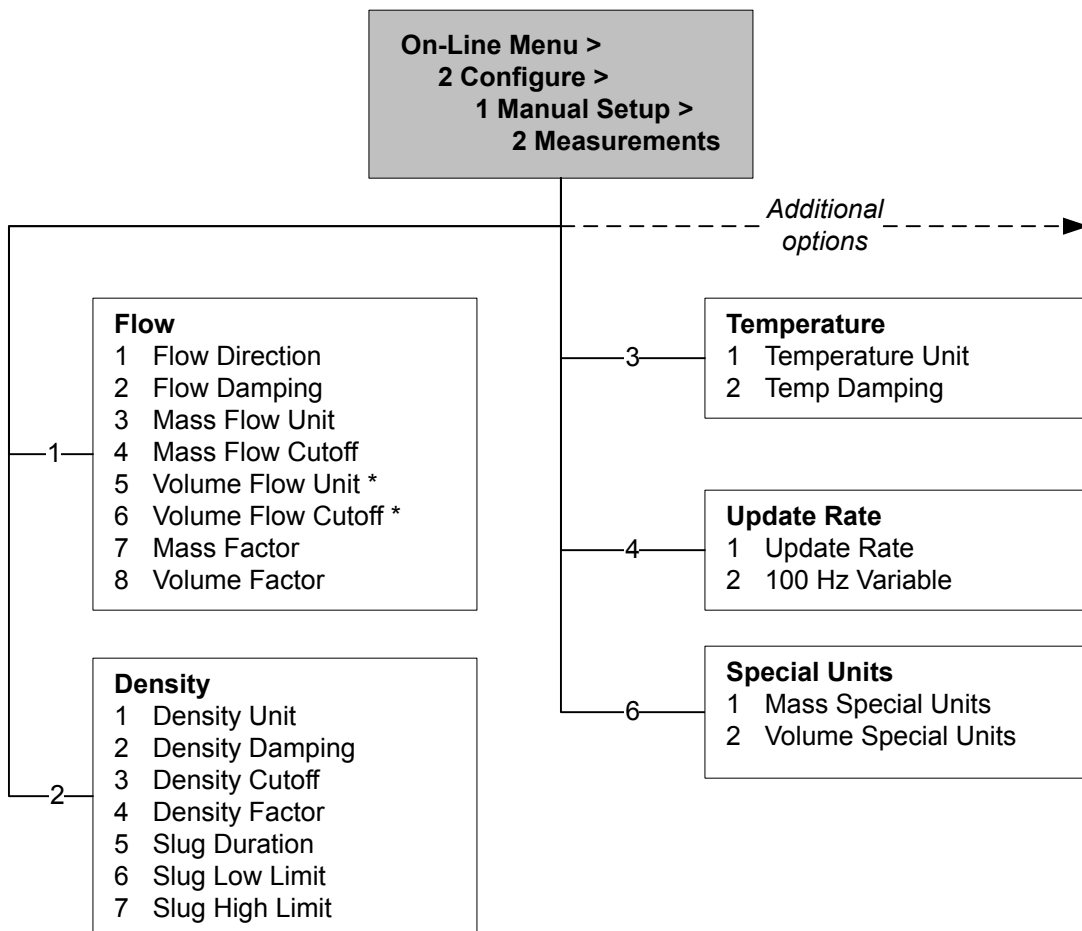


Figure D-9: Manual Setup menu: Measurements



* Displayed only if Volume Flow Type = Liquid.
Menu numbers are adjusted as required.

Figure D-10: Manual Setup menu: Measurements (continued)

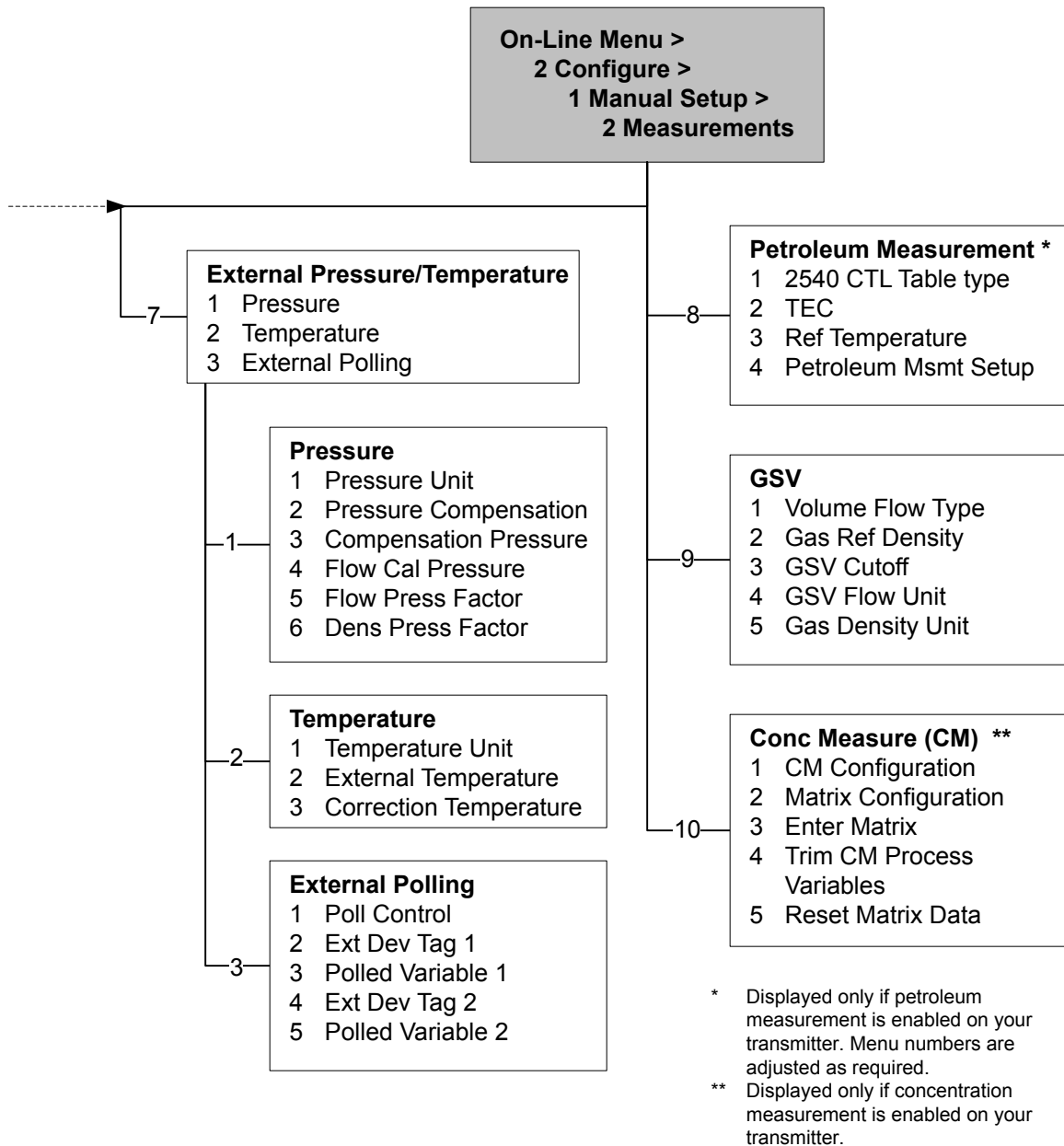


Figure D-11: Manual Setup menu: Display

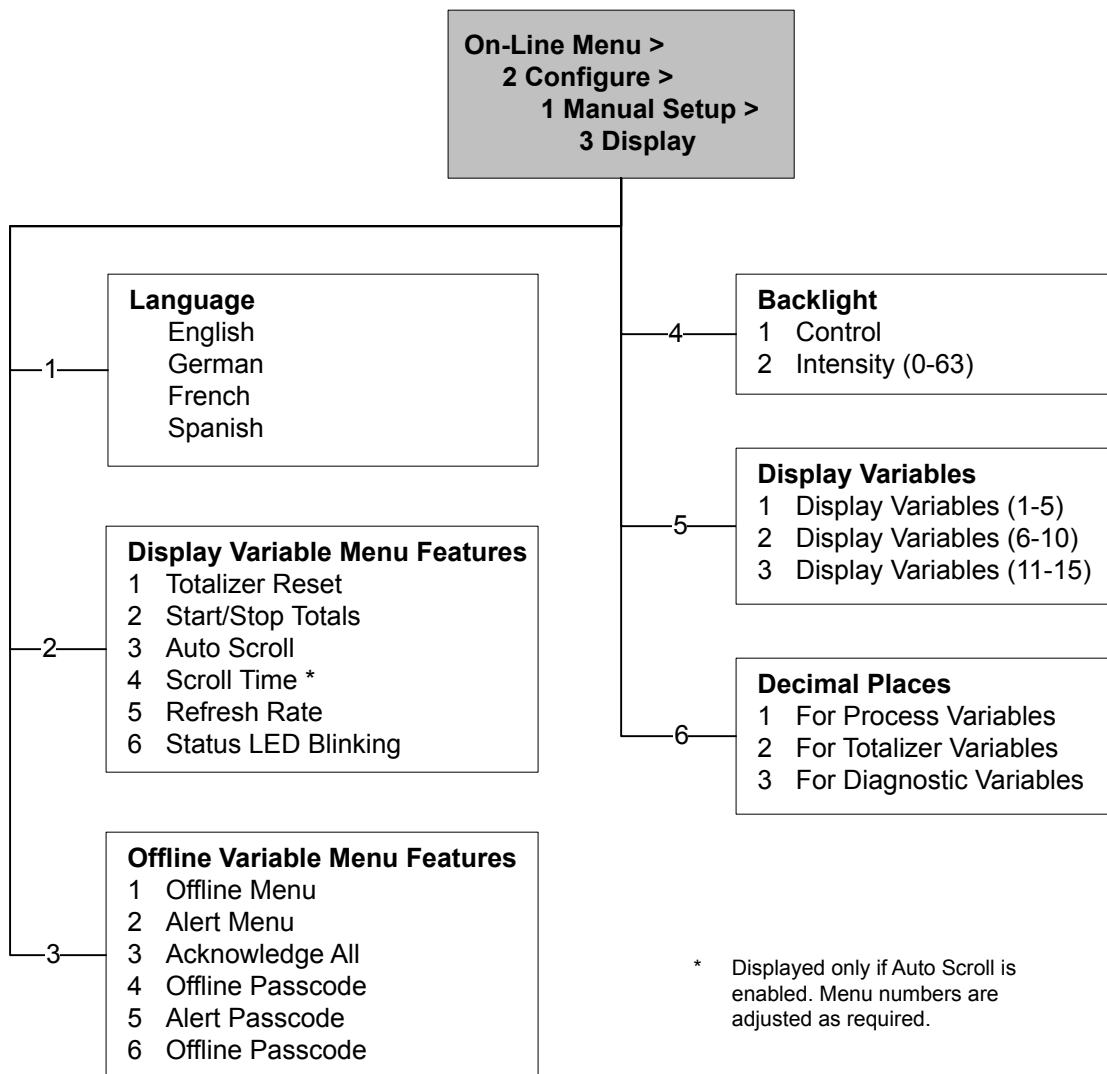


Figure D-12: Manual Setup menu: I/O

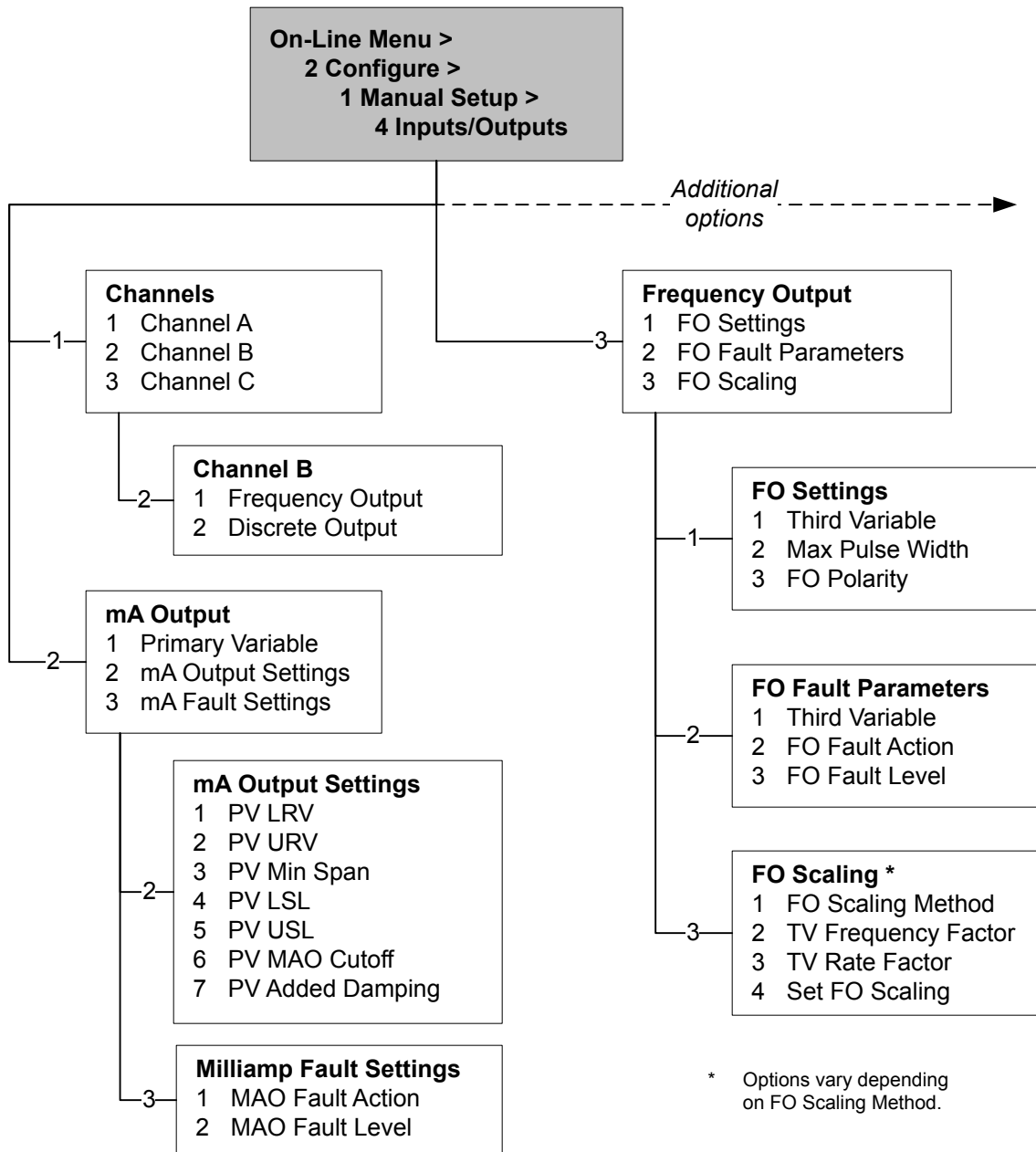


Figure D-13: Manual Setup menu: I/O (continued)

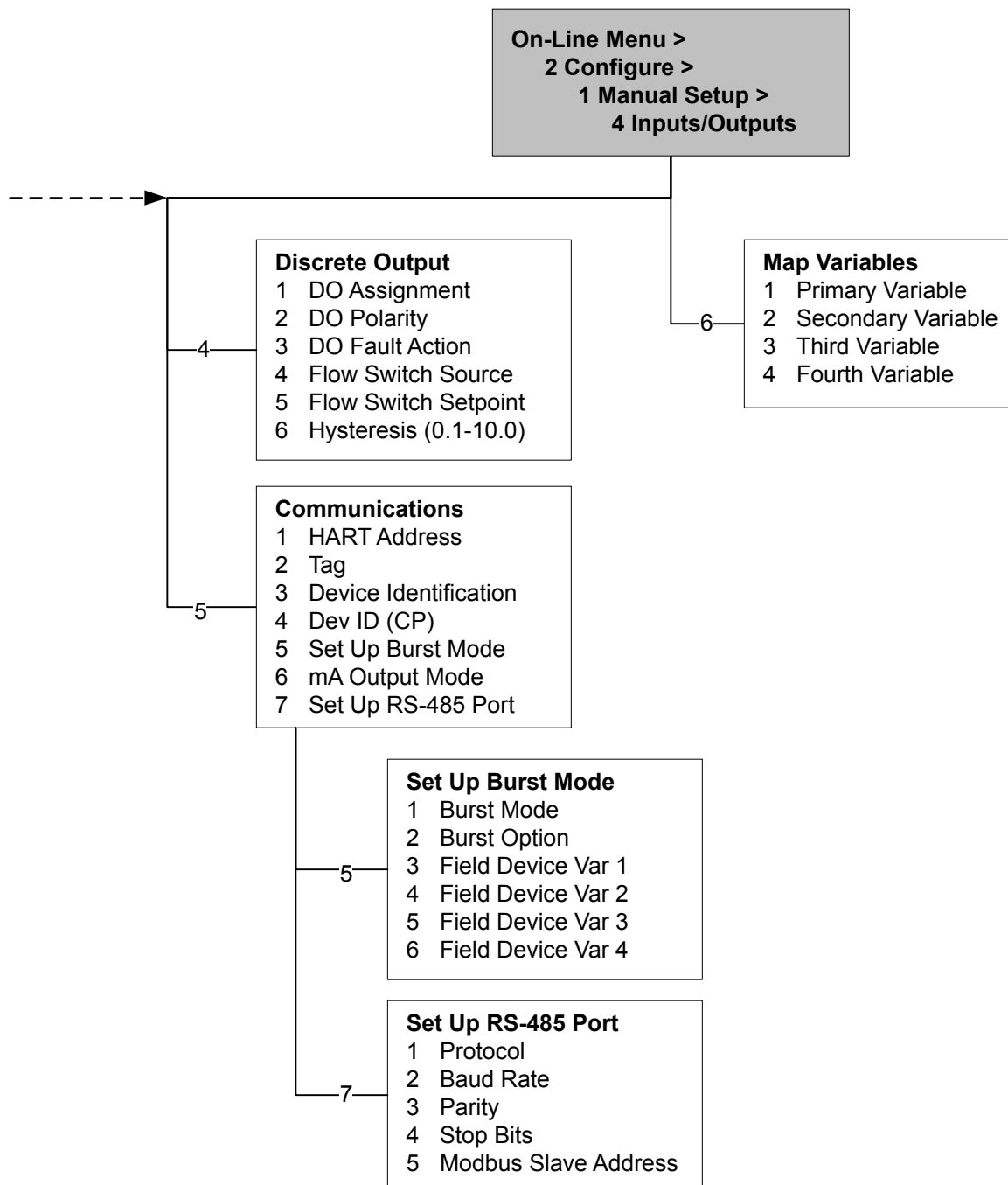


Figure D-14: Alert Setup menu

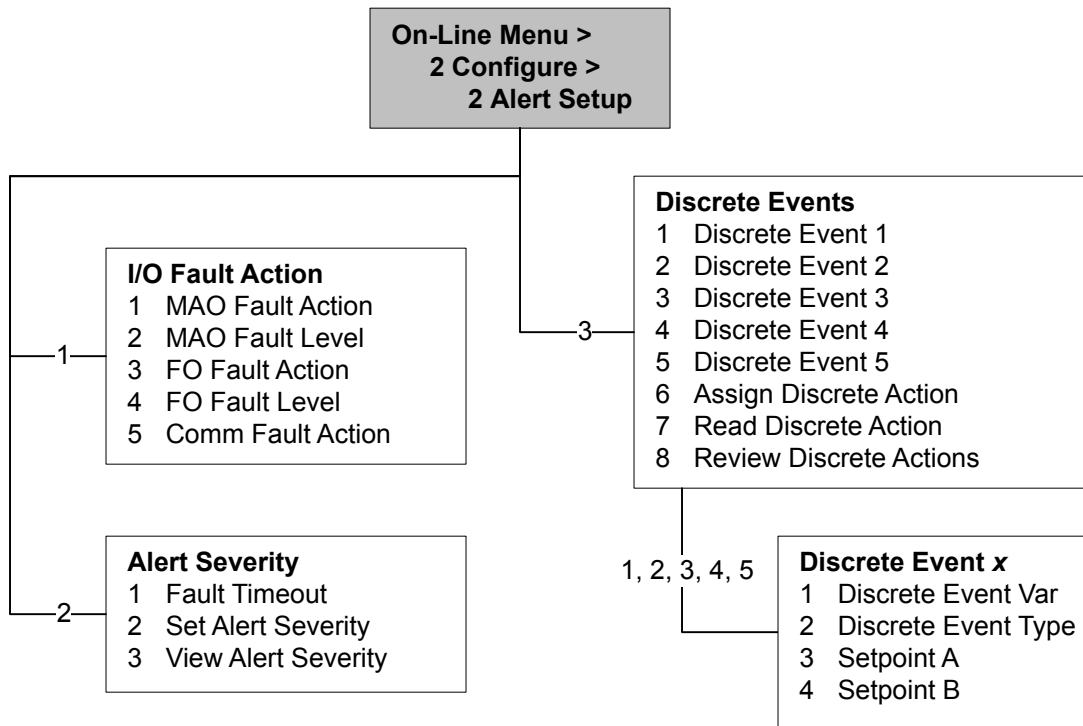


Figure D-15: Service Tools menu

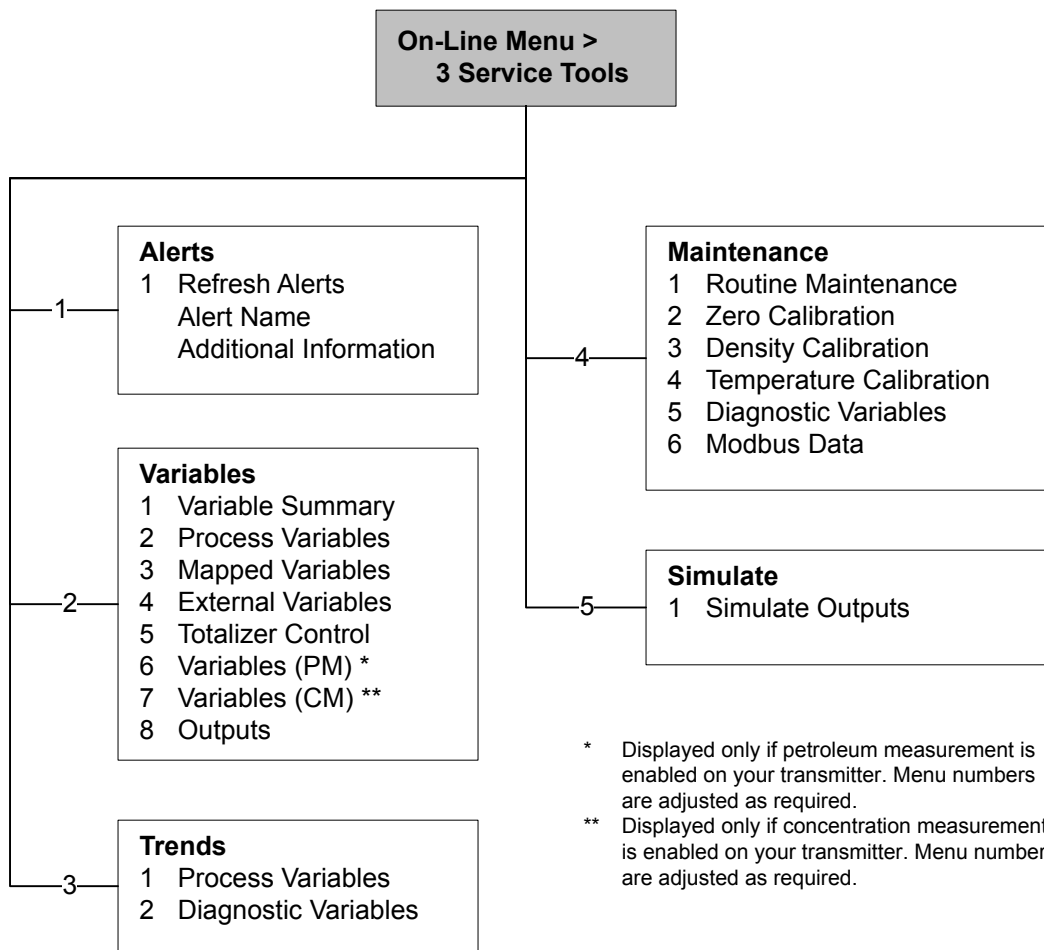


Figure D-16: Service Tools menu: Variables

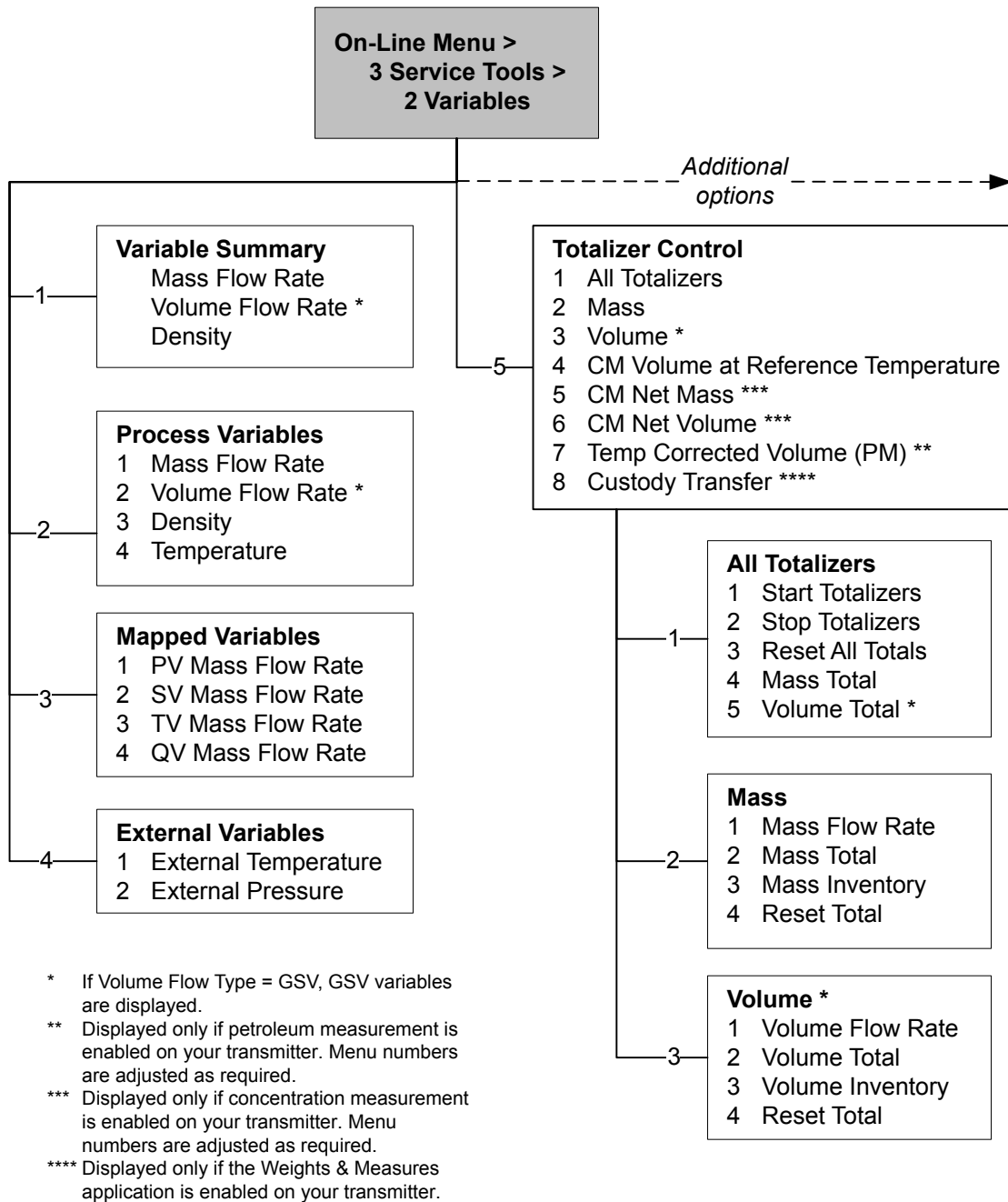
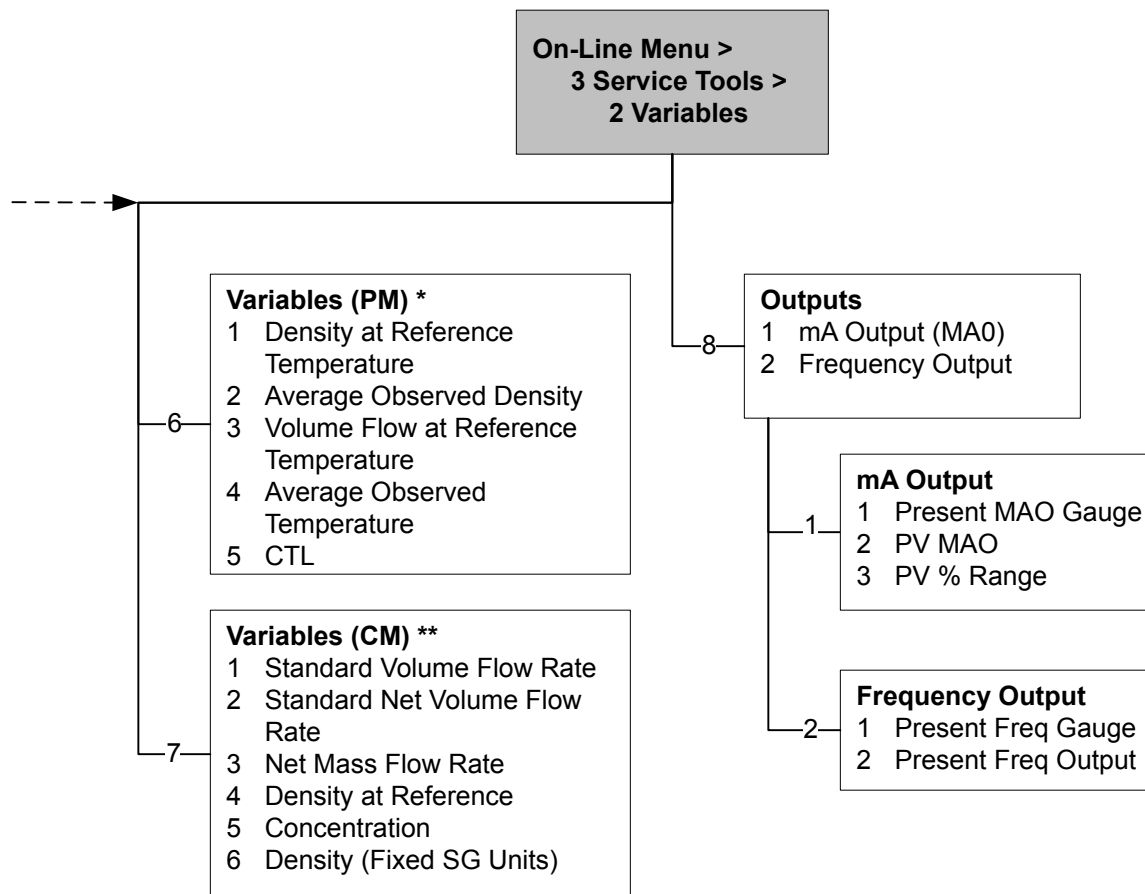


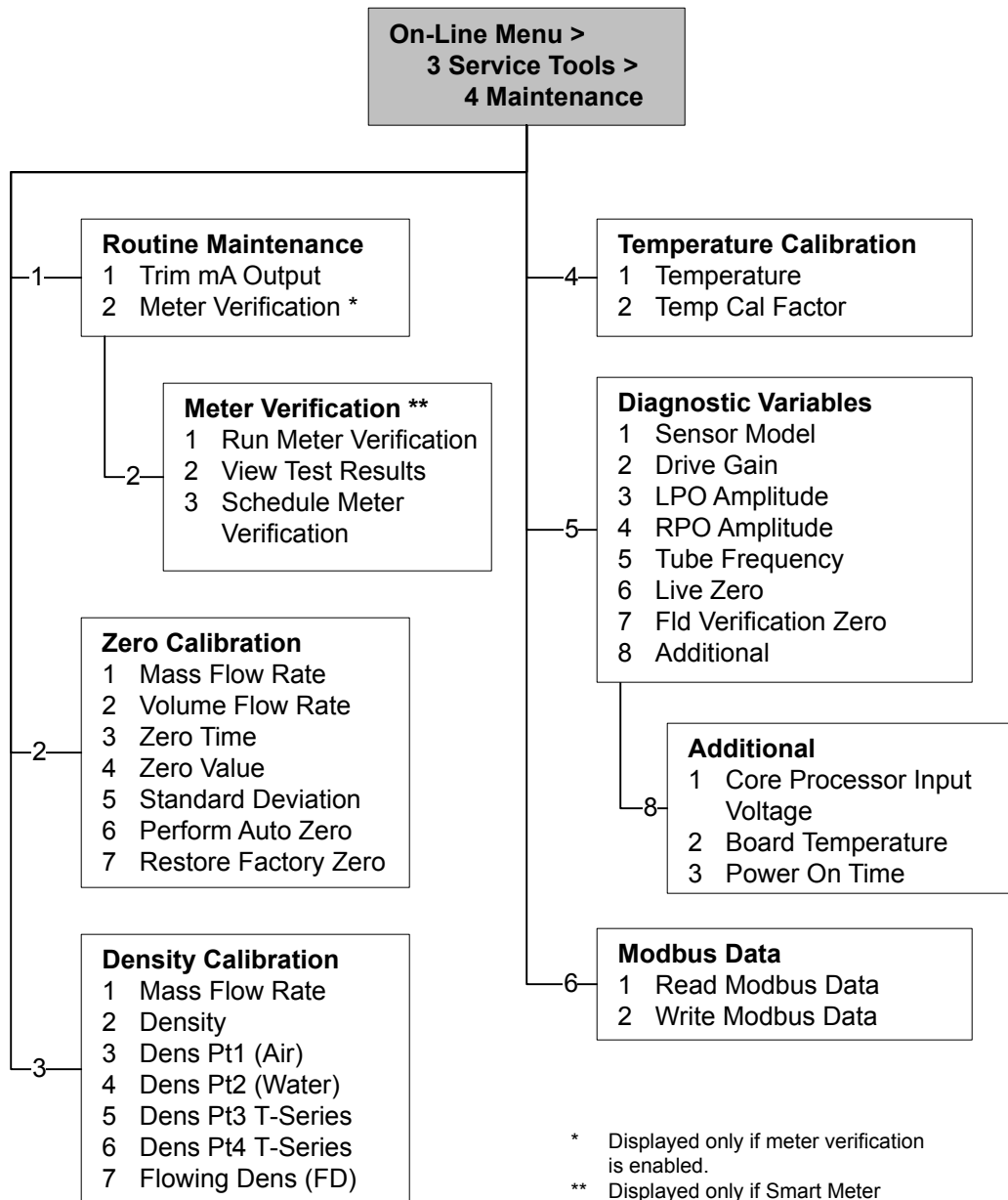
Figure D-17: Service Tools menu: Variables (continued)



* Displayed only if petroleum measurement is enabled on your transmitter. Menu numbers are adjusted as required.

** Displayed only if concentration measurement is enabled on your transmitter. Menu numbers are adjusted as required.

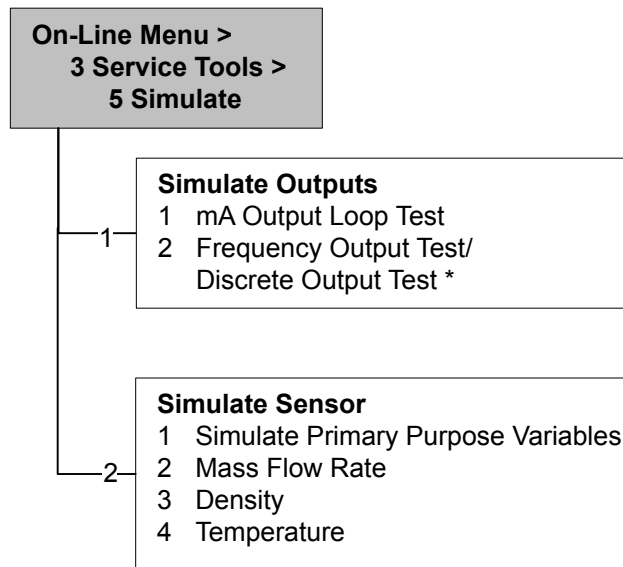
Figure D-18: Service Tools menu: Maintenance



* Displayed only if meter verification is enabled.

** Displayed only if Smart Meter Verification is enabled. For earlier versions, the Meter Verification Method is launched.

Figure D-19: Service Tools menu: Simulate



* Options vary depending on Channel settings.

Appendix E

Default values and ranges

E.1 Default values and ranges

The default values and ranges represent the typical factory transmitter configuration. Depending on how the transmitter was ordered, certain values may have been configured at the factory and are not represented in the default values and ranges.

Table E-1: Transmitter default values and ranges

Type	Parameter	Default	Range	Comments
Flow	Flow direction	Forward		
	Flow damping	0.8 sec ⁽¹⁾	0.0 – 60.0 sec	User-entered value is corrected to nearest lower value in list of preset values. In Special mode, the preset values are 1/5 normal. For gas applications, Micro Motion recommends a minimum value of 2.56.
	Flow calibration factor	1.00005.13		For T-Series sensors, this value represents the FCF and FT factors concatenated.
	Mass flow units	g/s		
	Mass flow cutoff	0.0 g/s		Recommended setting is 5% of the sensor's rated maximum flowrate.
	Volume flow type	Liquid		
	Volume flow units	L/s		
	Volume flow cutoff	0/0 L/s	0.0 – x L/s	x is obtained by multiplying the flow calibration factor by 0.2, using units of L/s.
Meter factors	Mass factor	1		
	Density factor	1		
	Volume factor	1		
Density	Density damping	1.6 sec	0.0 – 60.0 sec	User-entered value is corrected to nearest value in list of preset values.

(1) In Special mode, the default value is 0.64 sec.

Table E-1: Transmitter default values and ranges (continued)

Type	Parameter	Default	Range	Comments
	Density units	g/cm ³		
	Density cutoff	0.2 g/cm ³	0.0 – 0.5 g/cm ³	
	D1	0 g/cm ³		
	D2	1 g/cm ³		
	K1	1000 μsec	1000 – 50,000 μsec	
	K2	50,000 μsec	1000 – 50,000 μsec	
	FD	0		
	Temp Coefficient	4.44		
Slug flow	Slug flow low limit	0.0 g/cm ³	0.0 – 10.0 g/cm ³	
	Slug flow high limit	5.0 g/cm ³	0.0 – 10.0 g/cm ³	
	Slug duration	0.0 sec	0.0 – 60.0 sec	
Temperature	Temperature damping	4.8 sec	0.0 – 80 sec	User-entered value is corrected to nearest lower value in list of preset values.
	Temperature units	Deg C		
	Temperature calibration factor	1.00000T0.0000		
Pressure	Pressure units	PSI		
	Flow factor	0		
	Density factor	0		
	Cal pressure	0		
T-Series sensor	D3	0 g/cm ³		
	D4	0 g/cm ³		
	K3	0 μsec		
	K4	0 μsec		
	FTG	0		
	FFQ	0		
	DTG	0		
	DFQ1	0		
DFQ2	0			
Special units	Base mass unit	g		
	Base mass time	sec		
	Mass flow conversion factor	1		
	Base volume unit	L		

Table E-1: Transmitter default values and ranges (continued)

Type	Parameter	Default	Range	Comments
	Base volume time	sec		
	Volume flow conversion factor	1		
Variable mapping	Primary variable	Mass flow		
	Secondary variable	Density		
	Tertiary variable	Mass flow		
	Quaternary variable	Volume flow		
mA output 1	Primary variable	Mass flow		
	LRV	-200.00000 g/s		
	URV	200.00000 g/s		
	AO cutoff	0.00000 g/s		
	AO added damping	0.00000 sec		
	LSL	-200 g/s		Read-only. LSL is calculated based on the sensor size and characterization parameters.
	USL	200 g/s		Read only. USL is calculated based on the sensor size and characterization parameters.
	MinSpan	0.3 g/s		Read-only.
	Fault action	Downscale		
	AO fault level – downscale	2.0 mA	1.0 – 3.6 mA	
	AO fault level – upscale	22 mA	21.0 – 24.0 mA	
	Last measured value timeout	0.00 sec		
mA output 2	Secondary variable	Density		
	LRV	0.00 g/cm ³		
	URV	10.00 g/cm ³		
	AO cutoff	Not-A-Number		
	AO added damping	0.00000 sec		
	LSL	0.00 g/cm ³		Read-only. LSL is calculated based on the sensor size and characterization parameters.
	USL	10.00 g/cm ³		Read only. USL is calculated based on the sensor size and characterization parameters.
	MinSpan	0.05 g/cm ³		Read-only.

Table E-1: Transmitter default values and ranges (continued)

Type	Parameter	Default	Range	Comments
	Fault action	Downscale		
	AO fault level – downscale	2.0 mA	1.0 – 3.6 mA	
	AO fault level – upscale	22 mA	21.0 – 24.0 mA	
	Last measured value timeout	0.00 sec		
LRV	Mass flow rate	-200.000 g/s		
	Volume flow rate	-0.200 l/s		
	Density	0.000 g/cm ³		
	Temperature	-240.000 °C		
	Drive gain	0.000%		
	Gas standard volume flow rate	-423.78SCFM		
	External temperature	-240.000 °C		
	External pressure	0.000 psi		
URV	Mass flow rate	200.000 g/s		
	Volume flow rate	0.200 l/s		
	Density	10.000 g/cm ³		
	Temperature	450.000 °C		
	Drive gain	100.000%		
	Gas standard volume flow rate	423.78SCFM		
	External temperature	450.000 °C		
	External pressure	100.000 psi		
Frequency out-put	Tertiary variable	Mass flow		
	Frequency factor	1,000.00 Hz	0.001 – 10,000 Hz	
	Flow rate factor	1000 kg/min		
	Frequency pulse width	277.0 ms	0 or 0.5 – 277.5 ms	
	Scaling method	Freq=Flow		
	Frequency fault action	Downscale		
	Frequency fault level – upscale	15,000 Hz	10.0 – 15,000 Hz	
	Frequency output polarity	Active high		
	Last measured value timeout	0.0 seconds	0.0 – 60.0 sec	
Discrete out-put	Source	Flow direction		
	Fault Indicator	None		
	Power	Internal		
	Polarity	Active high		

Table E-1: Transmitter default values and ranges (continued)

Type	Parameter	Default	Range	Comments
Polarity	Active low			
Display	Backlight on/off	On		
	Backlight intensity	63	0 – 63	
	Refresh rate	200 milliseconds	100 – 10,000 milliseconds	
	Variable 1	Mass flow rate		
	Variable 2	Mass total		
	Variable 3	Volume flow rate		
	Variable 4	Volume total		
	Variable 5	Density		
	Variable 6	Temperature		
	Variable 7	Drive gain		
	Variable 8–15	None		
	Display totalizer start/stop	Disabled		
	Display totalizer reset	Disabled		
	Display auto scroll	Disabled		
	Display offline menu	Enabled		
	Display offline password	Disabled		
	Display alarm menu	Enabled		
	Display acknowledge all alarms	Enabled		
	Offline password	1234		
Auto scroll rate	10 sec			
Digital communications	Fault action	None		
	Fault timeout	0 seconds	0.0 – 60.0 sec	
	Modbus address	1		
	Modbus ASCII support	Enabled		
	Floating-point byte order	3–4–1–2		

Appendix F

Transmitter components and installation wiring

Topics covered in this appendix:

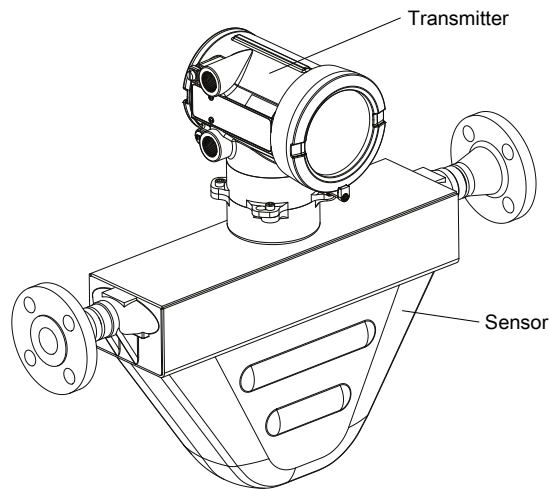
- *Installation types*
- *Power supply terminals and ground*
- *Input/output (I/O) wiring terminals*

F.1 Installation types

Model 1700 and Model 2700 transmitters can be installed five different ways, only one of which applies to your specific installation.

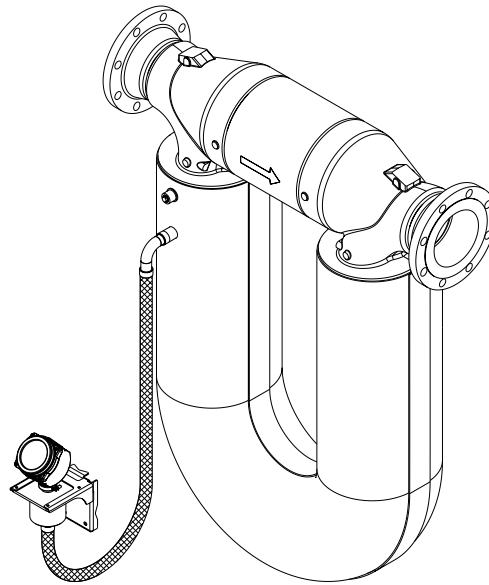
- **Integral** – The transmitter is mounted directly on the sensor. You do not need to install the transmitter separately, but you will need to connect power supply and I/O wiring.

Figure F-1: Integral installation



- **High-temperature flexible conduit** – Some high-temperature meters come preinstalled with a flexible conduit between the sensor and the transmitter. You do not have to connect any wires between the transmitter and the sensor, but you do need to mount the electronics separately and connect power and I/O wiring to the transmitter.

Figure F-2: High-temperature flexible conduit installation



High-temperature flexible conduit installations use the same installation instructions as 4-wire remote installations, except that the distance between the sensor and the electronics is limited by the length of the flexible conduit.

- **4-wire remote** – The transmitter is installed remotely from the sensor. You need to mount the transmitter separately from the sensor, connect a 4-wire cable between the transmitter and sensor, and connect power and I/O wiring to the transmitter.

Figure F-3: 4-wire remote installation – painted aluminum housing

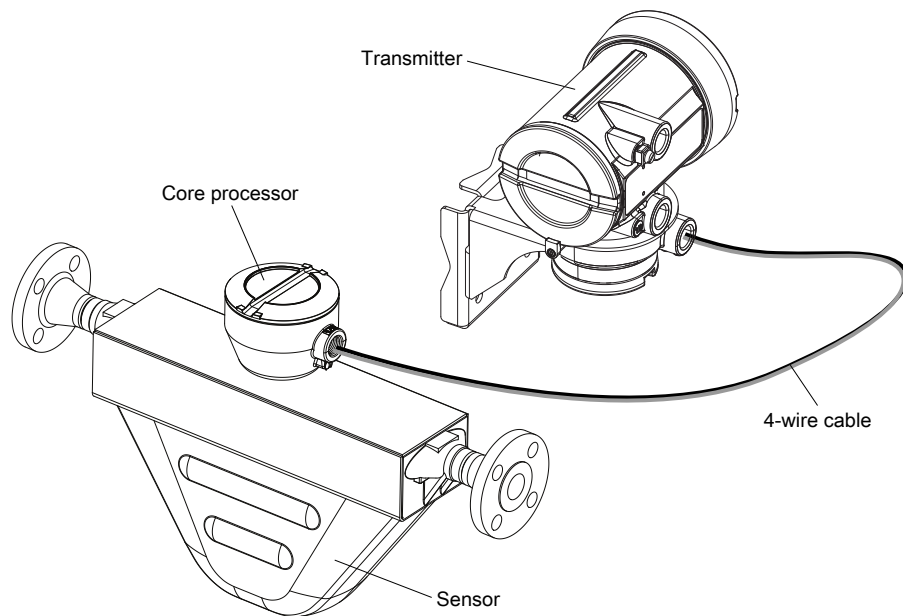
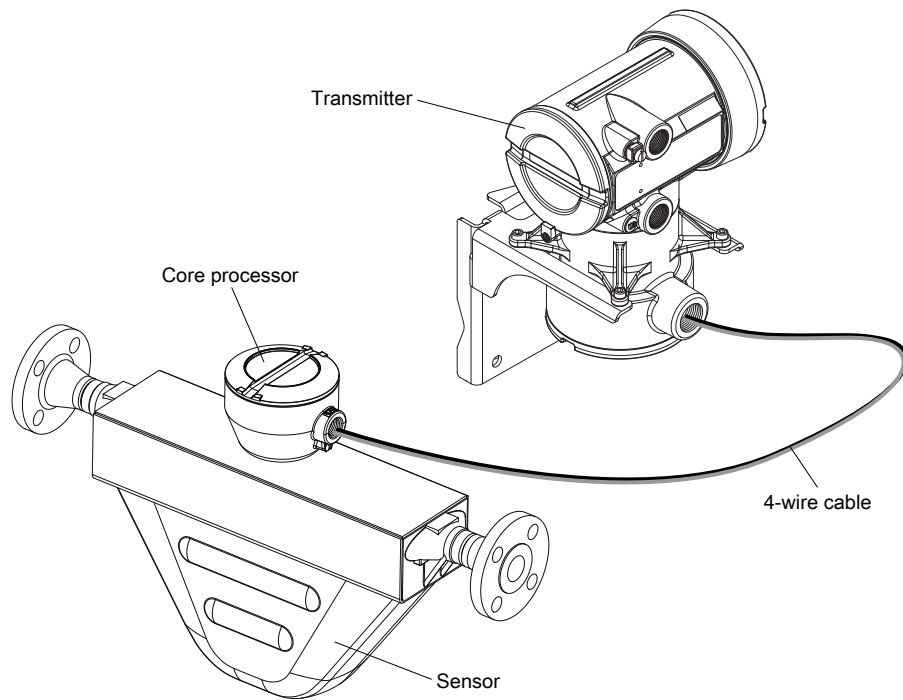
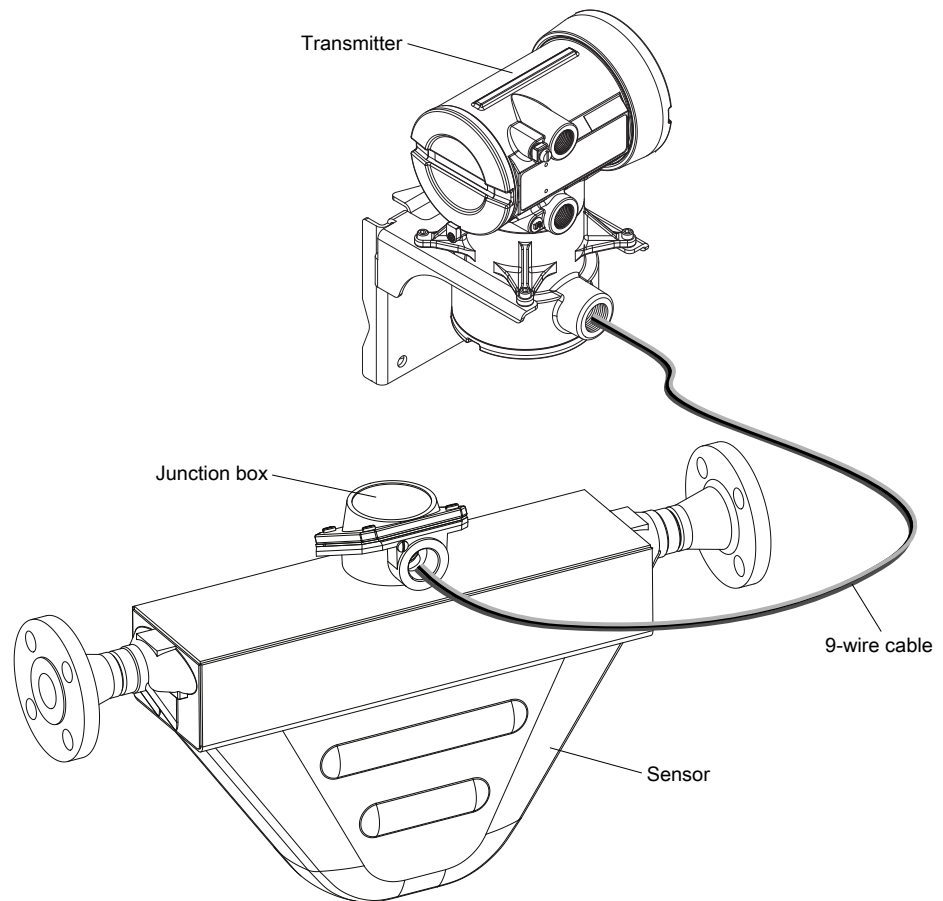


Figure F-4: 4-wire remote installation – stainless steel housing

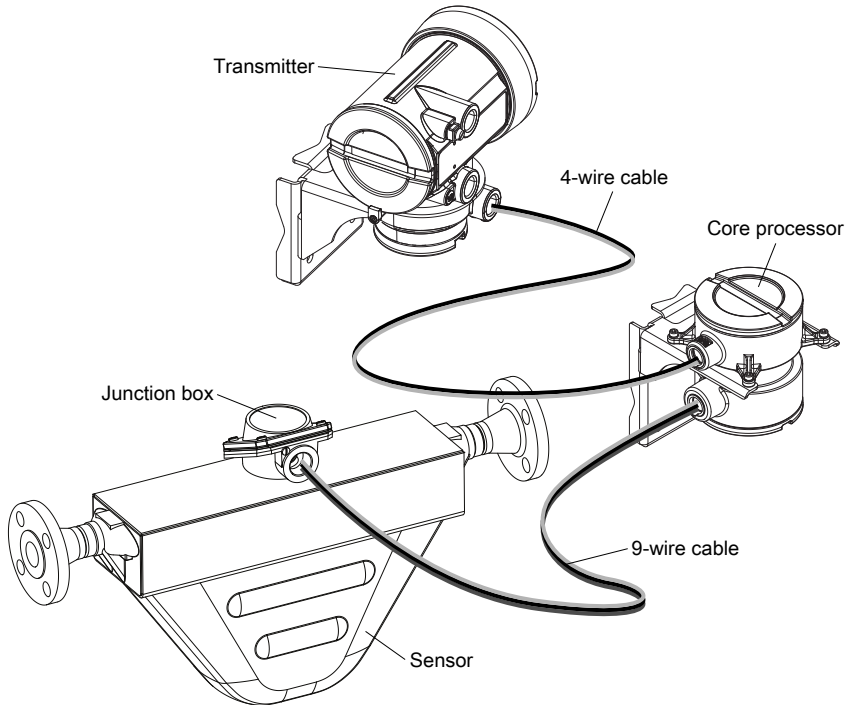
- **9-wire remote** – The transmitter and core processor are combined in a single unit that is installed remotely from the sensor. You need to mount the transmitter/core processor assembly separately from the sensor, connect a 9-wire cable between the transmitter/core processor, and connect power and I/O wiring to the transmitter.

Figure F-5: 9-wire remote installation type



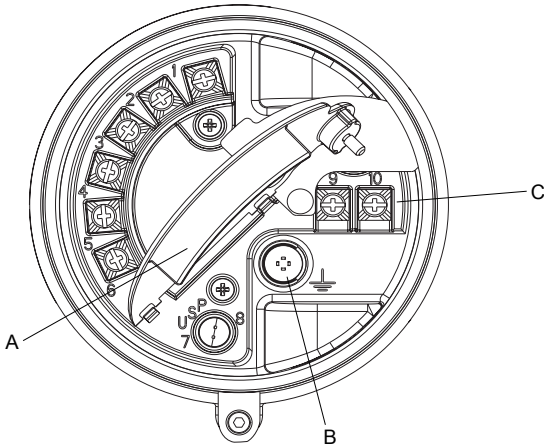
- **Remote core processor with remote sensor** – A remote core process with remote sensor installation separates all three components – transmitter, core processor, and sensor – all of which are installed separately. A 4-wire cable connects the transmitter to the core processor, and a 9-wire cable connects the core processor to the sensor.

Figure F-6: Remote core processor with remote sensor installation type



F.2 Power supply terminals and ground

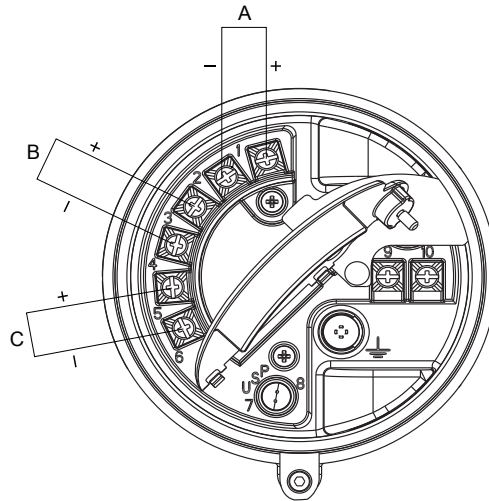
Figure F-7: Power supply wiring terminals



- A. Warning flap
- B. Equipment ground
- C. Power supply wiring terminals (9 and 10)

F.3 Input/output (I/O) wiring terminals

Figure F-8: I/O wiring terminals



- A. mA/HART
 - B. Frequency output or discrete output
 - C. RS-485
-

Appendix G

NE 53 history

G.1 NE 53 history

Date	Version	Type	Change	Operating instruction
08/2000	1.x	Expansion	Added writing of the device tag using Modbus	3600204 A
		Adjustment	Improved communication handling with the HART Tri-Loop product	
		Feature	Indication of outputs option board type appears on display at power-up	
05/2001	2.x	Expansion	Added alarm A106 to indicate that HART burst mode is enabled	3600204 B 3600647 A
			Added access to the transmitter in fault status bit via Modbus	
			Control of HART burst mode now available via Modbus	
			Added support for the Model 1700 transmitter	
			Added support for the I.S. (intrinsically safe) transmitter option	
			Added support to configure the process variable units for mass flow, volume flow, density and temperature from the display	
			Added support for assigning process variables to the mA and frequency output from the display	
		Adjustment	Clarified the interaction of the digital fault setting and the fault timeout (last measured value timeout)	
		Feature	Drive gain can be assigned to mA output	
			Pressure compensation added via HART	
Channel B can be configured as a discrete output				
12/2001	3.x	Expansion	Added support for the configurable I/O option board	3600647 B 3600785 A
			Software version information available via the display or Modbus	20000325 A 20000325 B
			Configurable density cutoff	20000150 A
			Additional HART variables can be assigned to QV	20000150 B 20000148 A

Date	Version	Type	Change	Operating instruction
			The display start/stop totalizers function can be enabled or disabled	
			Petroleum measurement application improvements	
			Live zero available as display variable	
			Increased options for fault output settings	
			New cryogenic application temperature algorithms	
		Adjustment	Improved frequency output stability and unit conversions	
			Improved the handling of volume flow rate when slug flow is detected	
			Improved handling of density values and calibrations during fault conditions	
			Display configuration, screen flow and optical switch changes	
			HART communication and burst mode improvements	
		Feature	Petroleum measurement application added	
			Custody transfer option added to Configurable I/O option board	
			HART polling for external pressure/temperature added	
06/2003	4.x	Expansion	Added support for the Model 1500 transmitter	20000325 C
			Additional variables displayed by the Model 1700 transmitter	20000150 C 3600647 C
		Adjustment	Improved the handling of certain alarm conditions	20000148 B
			Clarified the behavior of certain Modbus calibration coils	20001715 A
			Clarified the interaction between certain density measurement units and density cutoff values	
			Improved the handling of the mA source setting via the display	
			Improvements to pressure and temperature polling	
			HART Tri-Loop and other communication improvements	
			Clarified the value returned by Modbus scaled integer registers during a fault condition	
		Feature	Discrete values now available through Modbus	

Date	Version	Type	Change	Operating instruction
09/2006	5.x	Expansion	Discrete output assignable as a flow switch	20001715 B
			Discrete output fault indication configurability	
			Discrete input support for multiple action assignments	
			Added support for querying the display LED status via Modbus	
			Additional HART and Modbus commands	
			Process comparator expanded to five configurable events	
			Factory configuration restore function	
			Factory zero restore function	
			Alarm history expanded	
			Selectable write protection for configuration data	
			Expanded selection of source assignments for mA output	
		Expanded storage of mA range values		
		Expanded custody transfer application for independent implementation of NTEP and OIML compliance		
		Adjustment	Display improvements for floating-point data	
Feature	Configurable alarm severity			
	Gas standard volume functionality			
	Meter verification availability as an option			
	Multiple display language selections			
09/2009	6.x	Expansion	Frequency output configurable as discrete output on Series 1000 transmitters	20001715 BA
			Discrete output assignable as flow switch on Series 1000 transmitters	
			Display Variable 1 optionally fixed to process variable assigned to primary mA output	
			Frequency output scaling method and related parameters configurable from display	
			For enhanced density and petroleum measurement process variables, display cycles among variable name, current value and unit, and reference temperature	

Date	Version	Type	Change	Operating instruction
		Adjustment	The following combinations are not allowed: <ul style="list-style-type: none"> • mA Output Fault Action = None and Digital Communications Fault Action = NAN • Frequency Output Fault Action = None and Digital Communications Fault Action = NAN 	
			Display variables set to a volume process variable automatically switch between liquid and GSV, according to current setting of Volume Flow Type	
		Feature	Configurable hysteresis for flow switch Field Verification Zero added to support Weights & Measures application Transmitter firmware checksum and core processor firmware checksum assignable as display variables and viewable in ProLink II	

Index

A

Added Damping 105
 Additional Communications Response Delay 130
 address
 HART address 124, 129
 Modbus address 130
 air calibration, *See* calibration, density
 alarm menu, *See* display
 alarms
 alarm codes 208
 configuring alarm handling 89
 Status Alarm Severity
 configuring 90
 options 91
 transmitter response 157
 troubleshooting 208
 viewing and acknowledging
 using ProLink II 155
 using ProLink III 156
 using the display 152
 using the Field Communicator 156
 alerts, *See* alarms
 AO Cutoff 104
 API, *See* petroleum measurement application
 Auto Scroll 81

B

backups 137
 basic events, *See* events
 burst mode 125

C

Calculation Speed 89
 calibration
 definition 173
 density D1 and D2
 overview 194
 using ProLink II 194
 using ProLink III 196
 using the Field Communicator 197
 density D3 and D4
 overview 199
 using ProLink II 199

 using ProLink III 200
 using the Field Communicator 201
 temperature 203
 calibration parameters, *See* characterizing
 calibration pressure, *See* pressure compensation
 channel configuration 99
 characterizing
 density parameters 12
 flow calibration parameters 13
 parameters on sensor tags 10
 procedure 10
 communications, *See* digital communications
 protocols 3
 communications tools 3
 concentration measurement application
 configuring
 using ProLink II 58
 using ProLink III 61
 using the Field Communicator 64
 derived variables and calculated process variables 67
 overview 58
 standard matrices 66
 configuration
 backing up 137
 channel 99
 concentration measurement application, *See*
 concentration measurement application
 default values 341
 density measurement 45
 digital communications 124
 discrete outputs 114
 display 77, 82, 85
 events
 basic 121
 enhanced 121
 flowchart 19
 frequency outputs 108
 gas standard volume flow measurement 34
 informational parameters 94
 mA outputs 100
 mass flow measurement 23
 petroleum measurement application, *See* petroleum
 measurement application
 pressure compensation, *See* pressure compensation
 response times 86

- restore factory configuration
 - using ProLink II 22
 - using ProLink III 22
- temperature measurement 50
- volume flow measurement 29
- Weights & Measures, *See* Weights & Measures application
- write-protection 21, 138
- connection
 - Field Communicator 322
 - ProLink II
 - types 274
 - ProLink III
 - types 298
 - startup connection 9
- CTL 53
- curve, *See* concentration measurement application
- custody transfer, *See* Weights & Measures application
- customer service
 - contacting ii
- cutoffs
 - AO cutoff 104
 - density 50
 - interaction between AO Cutoff and process variable
 - cutoffs 104
 - mass flow 27
 - troubleshooting 238
 - volume flow 33
- D**
- damping
 - Added Damping 105
 - density damping 48
 - flow damping 26
 - interaction between Added Damping and process variable damping 106
 - on mA outputs 105
 - temperature damping 51
- Date 96
- DD, *See* HART device description (DD)
- deadband, *See* hysteresis
- decimal notation, *See* display, decimal notation
- decimal values
 - entering from display 254
 - precision of display variables 79
- default values 341
- density
 - See also* standard density
- density calibration, *See* calibration, density
- density factor, *See* pressure compensation
- density measurement
 - configuring 45
 - cutoff
 - configuring 50
 - effect on volume measurement 50
 - damping
 - effect on volume measurement 49
 - interaction with added damping 50
 - measurement units
 - configuring 46
 - options 46
 - meter factor 192
 - slug flow
 - configuring 47
 - transmitter behavior 48
 - troubleshooting 238
 - troubleshooting 222
- derived variable, *See* concentration measurement application
- Descriptor 95
- device description (DD), *See* HART device description (DD)
- diagnostics
 - loop testing
 - using ProLink II 230
 - using ProLink III 231
 - using the display 228
 - using the Field Communicator 233
 - sensor simulation 135
 - Smart Meter Verification 173
- digital communications
 - configuring HART/Bell 202 parameters 124
 - configuring HART/RS-485 parameters 129
 - configuring Modbus/RS-485 parameters 130
 - Digital Communications Fault Action
 - configuring 131
 - options 132
- Digital Communications Fault Action 131
- discrete outputs
 - configuring 114
 - Fault Action
 - configuring 119
 - options 120
 - fault indication 120
 - flow switch 117
 - loop testing
 - using ProLink II 230
 - using ProLink III 231
 - using the display 228
 - using the Field Communicator 233

- polarity
 - configuring 118
 - options 118
 - source
 - configuring 115
 - options 115
 - display
 - accessing menu system 253
 - components 251
 - configuring display behavior
 - Auto Scroll 81
 - backlight 81
 - display language 77
 - display precision 79
 - display variables 78
 - LED Blinking 82
 - Update Period (refresh rate) 80
 - configuring security
 - access to alarm menu 85
 - access to off-line menu 85
 - alarm password 85
 - off-line password 85
 - decimal notation 254
 - enabling or disabling operator actions
 - acknowledging all alarms 84
 - resetting totalizers 83
 - starting and stopping totalizers 83
 - exponential notation 254
 - floating-point values 254
 - menu codes 259
 - menu maps 262
 - optical switches 252
 - process variable codes 257
 - status LED states 208
 - totalizer values and Weights & Measures
 - application 164
 - documentation 4
 - drive gain
 - collecting data 240
 - troubleshooting 239
- E**
- electrical shorts
 - troubleshooting 241
 - enhanced density, *See* concentration measurement application
 - enhanced events, *See* events
 - entrained gas, *See* density measurement, slug flow events
 - configuring basic events 121
 - configuring enhanced events 121
 - Enhanced Event Action
 - configuring 121
 - options 123
 - event models 120
 - exponential notation, *See* display, exponential notation
- F**
- Fault Action
 - affected by Fault Timeout 90
 - digital communications 131
 - discrete outputs 119
 - frequency outputs 113
 - mA outputs 107
 - Fault Timeout
 - configuring 90
 - effect on Fault Action 90
 - Field Communicator
 - connecting to the transmitter 322
 - device description (DD) 321
 - menu maps 324
 - overview 321, 322
 - startup connection 9
 - Field Verification Zero (FVZ), *See* Weights & Measures application
 - Floating-Point Byte Order 130
 - floating-point values, *See* display, floating-point values
 - flow damping
 - configuring 26
 - effect on volume measurement 27
 - interaction with added damping 27
 - flow direction
 - troubleshooting 237
 - Flow Direction
 - configuring 40
 - effect on digital communications 44
 - effect on discrete outputs 44
 - effect on frequency outputs 44
 - effect on mA outputs 41
 - effect on totalizers and inventories 45
 - options 41
 - flow factor, *See* pressure compensation
 - flow switch 117
 - Frequency Factor 111
 - frequency outputs
 - configuring 108
 - Fault Action
 - configuring 113
 - options 114
 - loop testing
 - using ProLink II 230
 - using ProLink III 231

- using the display 228
 - using the Field Communicator 233
- maximum pulse width 112
- polarity
 - configuring 110
 - options 110
- process variable
 - configuring 108
 - options 109
- scaling method
 - configuring 111
 - Frequency = Flow 111
- troubleshooting 225, 237

G

- gas standard volume flow measurement
 - configuring 34
 - cutoff
 - configuring 39
 - interaction with AO cutoff 39
 - effect of flow damping on 27
 - effect of mass flow cutoff on 28
 - measurement units
 - configuring 36
 - options 36
 - standard density 35
 - volume flow type 35
- ground 351
- grounding
 - troubleshooting 228
- GSV, *See* gas standard volume flow measurement

H

- HART
 - address 124, 129, 235
 - burst mode 125, 236
 - device description (DD) 321
 - HART/Bell 202
 - configuring 124
 - Field Communicator connections 322
 - HART/RS-485
 - configuring 129
 - loop 235
 - Loop Current Mode 124, 235
 - variables
 - configuring 126
 - interaction with transmitter outputs 128
 - options 127
- hysteresis 117

I

- I/O terminals 352
- informational parameters 94
- installation types
 - 4-wire remote 347
 - 9-wire remote 347
 - high-temperature flexible conduit 347
 - integral 347
 - remote core processor with remote transmitter 347
- inventories
 - resetting 161
 - starting and stopping 158

L

- language
 - for display 77
- Last Measured Value Timeout, *See* Fault Timeout
- LD Optimization 194, 196, 197
- LED, *See* status LED
- local display, *See* display
- Local Operator Interface (LOI), *See* display
- Loop Current Mode 124, 235
- loop testing
 - using ProLink II 230
 - using ProLink III 231
 - using the display 228
 - using the Field Communicator 233
- Lower Range Value (LRV) 102

M

- mA outputs
 - Added Damping
 - configuring 105
 - interaction with density damping 50
 - interaction with flow damping 27
 - AO cutoff
 - configuring 104
 - interaction with volume flow cutoff 33
 - configuring 100
 - Fault Action
 - configuring 107
 - options 107
 - loop testing
 - using ProLink II 230
 - using ProLink III 231
 - using the display 228
 - using the Field Communicator 233
 - Lower Range Value and Upper Range Value
 - configuring 102
 - default values 103

- process variable
 - configuring 100
 - options 101
 - scaling 102
 - troubleshooting 224, 236
 - mass flow measurement
 - configuring 23
 - cutoff
 - configuring 27
 - effect on volume measurement 28
 - interaction with AO cutoff 28
 - flow damping 26
 - measurement units
 - configuring 23
 - options 24
 - meter factor 192
 - troubleshooting 220
 - matrix, *See* concentration measurement application
 - Maximum Pulse Width 112
 - measurement units
 - density
 - configuring 46, 48
 - options 46
 - gas standard volume flow rate
 - configuring 36
 - options 36
 - special unit 37
 - mass flow rate
 - configuring 23
 - options 24
 - special unit 25
 - pressure
 - options 74
 - temperature
 - configuring 51
 - options 51
 - volume flow rate
 - configuring 30
 - options 30
 - special unit 32
 - menu maps
 - display 262
 - Field Communicator 324
 - ProLink II 287
 - ProLink III 311
 - Message 95
 - meter factors, *See* meter validation
 - meter validation
 - alternate method for volume flow 193
 - definition 173
 - standard method 192
 - meter verification, *See* Smart Meter Verification
 - metrological security, *See* Weights & Measures application
 - Modbus
 - Additional Communications Response Delay 130
 - address 130
 - configuring Modbus/RS-485 digital communications 130
 - Floating-Point Byte Order 130
 - model code 3
- N**
- National Type Evaluation Program (NTEP), *See* Weights & Measures application
- O**
- off-line menu, *See* display
 - optical switches 252
 - Organization of Legal Metrology (OIML), *See* Weights & Measures application
- P**
- password
 - alarm password 85
 - off-line password 85
 - petroleum measurement application
 - API reference tables 57
 - configuring
 - using ProLink II 53
 - using ProLink III 54
 - using the Field Communicator 56
 - overview 53
 - physical security, *See* Weights & Measures application
 - pickoffs
 - collecting data 241
 - troubleshooting 240
 - polarity
 - discrete outputs 118
 - frequency outputs 110
 - polling
 - pressure
 - using ProLink II 69
 - using the Field Communicator 73
 - temperature
 - concentration measurement application
 - using ProLink II 58
 - using ProLink III 61
 - using the Field Communicator 64
 - petroleum measurement application
 - using ProLink II 53

- using ProLink III 54
 - using the Field Communicator 56
 - polling address, *See* HART address
 - power
 - power up 7
 - power supply terminals 351
 - power supply wiring
 - troubleshooting 227
 - pressure compensation
 - configuring
 - using ProLink II 69
 - using the Field Communicator 73
 - overview 69
 - pressure measurement units
 - options 74
 - primary variable (PV) 126
 - process measurement
 - effect of Calculation Speed 89
 - effect of Update Rate 87, 88
 - process variables
 - See also* density measurement
 - See also* gas standard volume flow measurement
 - See also* mass flow measurement
 - See also* temperature measurement
 - See also* volume flow measurement
 - codes used on the display 257
 - configuring display variables 78
 - recording values 149
 - viewing values 150
 - ProLink II
 - connecting
 - HART/Bell 202 276
 - HART/RS-485 281, 305
 - Modbus/RS-485 284
 - service port 275
 - startup connection 9
 - connection types 274
 - menu maps 287
 - overview 273, 274
 - requirements 273
 - ProLink III
 - connecting
 - HART/Bell 202 300
 - Modbus/RS-485 308
 - service port 299
 - startup connection 9
 - connection types 298
 - connecting to the transmitter 298
 - menu maps 311
 - overview 297, 298
 - requirements 297, 298
 - protocols 3
 - proving, *See* meter validation
 - pulse width 112
- ## Q
- quaternary variable (QV) 126
- ## R
- radio frequency interference (RFI)
 - troubleshooting 234
 - Rate Factor 111
 - reference density, *See* standard density
 - refresh rate
 - display 80
 - Response Time 89
- ## S
- safety messages ii
 - scaling
 - frequency outputs 111
 - mA outputs 102
 - Scroll Rate 81
 - seal, *See* Weights & Measures application
 - secondary variable (SV) 126
 - secured, *See* Weights & Measures application
 - security
 - See also* Weights & Measures application
 - access to display menus 85
 - security breach, *See* Weights & Measures application
 - sensor coils
 - troubleshooting 241, 242
 - Sensor Flange Type 98
 - Sensor Liner Material 97
 - Sensor Material 97
 - Sensor Serial Number 96
 - sensor simulation
 - overview 136
 - troubleshooting 226
 - using ProLink II 135
 - using ProLink III 135
 - using the Field Communicator 135
 - sensor wiring
 - troubleshooting 227
 - shorts
 - troubleshooting 241
 - simulation
 - sensor simulation
 - using ProLink II 135
 - using ProLink III 135
 - using the Field Communicator 135

slave address, *See* Modbus address
slug flow, *See* density measurement, slug flow
Smart Meter Verification
 automatic execution and scheduling
 using ProLink II 185
 using ProLink III 186
 using the display 184
 using the Field Communicator 186
 definition 173
 preparing for a test 174
 requirements 174
 running a test
 using ProLink II 177
 using ProLink III 178
 using the display 175
 using the Field Communicator 179
 test results
 contents 179
 interpreting 182
 viewing using ProLink II 182
 viewing using ProLink III 182
 viewing using the display 180
 viewing using the Field Communicator 182
software security, *See* Weights & Measures application
special measurement units
 gas standard volume flow rate 37
 mass flow rate 25
 volume flow rate 32
standard density 35
status
 See also alarms
status alarms, *See* alarms
status LED 152, 208

T

temperature calibration, *See* calibration, temperature
temperature measurement
 configuring 50
 damping
 configuring 51
 effect on process measurement 52
 measurement units
 configuring 51
 options 51
 troubleshooting 223
tertiary variable (TV) 108, 126
testing
 loop testing
 using ProLink II 230, 231
 using the display 228
 using the Field Communicator 233

 system testing
 using ProLink II 135
 using the Field Communicator 135
Thermal Expansion Coefficient (TEC) 53
totalizers
 displaying values and Weights & Measures
 application 164
 resetting
 enabling display function 83
 options for Weights & Measures
 application 140, 143
 performing action 160
 starting and stopping
 enabling display function 83
 performing action 158
transmitter
 communications protocols 3
 ground 351
 I/O terminals 352
 installation types 347
 model code 3
 power supply terminals 351
transmitter interface
 See also display
 components 251
troubleshooting
 alarms 208
 density measurement 238
 discrete outputs 234, 237
 drive gain 238, 239
 electrical shorts 241, 242
 frequency outputs 225, 234, 237
 grounding 228
 HART communications 235, 236
 mA outputs 224, 236–238
 mass flow measurement 220, 237, 238
 pickoff voltage 240
 radio frequency interference (RFI) 234
 restore factory configuration
 using ProLink II 22
 using ProLink III 22
 slug flow (two-phase flow) 238
 status LED 208
 system testing 226
 temperature measurement 223
 volume flow measurement 220, 237, 238
 wiring 227
two-phase flow, *See* density measurement, slug flow

U

unit, *See* measurement units

unsecured, *See* Weights & Measures application

Update Period 80

Update Rate

 configuring 87

 effect on process measurement 88

 incompatible functions 88

Upper Range Value (URV) 102

V

Volume Correction Factor (VCF) 53

volume flow measurement

 configuring 29

 cutoff

 configuring 33

 interaction with AO cutoff 33

 effect of density cutoff on 50

 effect of density damping on 49

 effect of flow damping on 27

 effect of mass flow cutoff on 28

 measurement units

 configuring 30

 options 30

 meter factor 192, 193

 troubleshooting 220

 volume flow type 29

volume flow type

 gas applications 35

 liquid applications 29

W

water calibration, *See* calibration, density

Weights & Measures application

 effect on operations and maintenance

 NTEP 166

 OIML 167

 effect on outputs

 NTEP 165

 OIML 166

 effect on process variables

 NTEP 165

 OIML 166

 operations overview 163

 overview 139, 140

 process data

 NTEP 164

 OIML 164

regulatory agencies 139

replacing the core processor 171

sealing 140, 143

secured vs. unsecured 139

security types 139

setting up

 using ProLink II 140

 using ProLink III 143

Status Alarm A027:Security Breach 139, 170

switching modes

 using ProLink II 169

 using ProLink III 169

 using the switching utility 170

totalizer reset options 140, 143

wiring

 ground 351

 grounding

 troubleshooting 228

 I/O terminals 352

 power supply terminals 351

 power supply wiring

 troubleshooting 227

 sensor wiring

 troubleshooting 227

write-protection 21, 138

Z

zero

 procedure

 using ProLink II 188

 using ProLink III 189

 using the display 187

 using the Field Communicator 191

 restore factory zero

 using ProLink II 188

 using ProLink III 189

 using the display 187

 using the Field Communicator 191

 restore prior zero

 using ProLink II 188

 using ProLink III 189

 using the display 187

 using the Field Communicator 191

 verification

 using ProLink II 14

 using ProLink III 15



MMI-20019043

Rev AA

2012

Micro Motion Inc. USA

Worldwide Headquarters
7070 Winchester Circle
Boulder, Colorado 80301
T +1 303-527-5200
T +1 800-522-6277
F +1 303-530-8459

www.micromotion.com

Micro Motion Europe

Emerson Process Management
Neonstraat 1
6718 WX Ede
The Netherlands
T +31 (0) 318 495 555
F +31 (0) 318 495 556

www.micromotion.nl

Micro Motion Asia

Emerson Process Management
1 Pandan Crescent
Singapore 128461
Republic of Singapore
T +65 6777-8211
F +65 6770-8003

Micro Motion United Kingdom

Emerson Process Management Limited
Horsfield Way
Bredbury Industrial Estate
Stockport SK6 2SU U.K.
T +44 0870 240 1978
F +44 0800 966 181

Micro Motion Japan

Emerson Process Management
1-2-5, Higashi Shinagawa
Shinagawa-ku
Tokyo 140-0002 Japan
T +81 3 5769-6803
F +81 3 5769-6844

©2012 Micro Motion, Inc. All rights reserved.

The Emerson logo is a trademark and service mark of Emerson Electric Co. Micro Motion, ELITE, ProLink, MVD and MVD Direct Connect marks are marks of one of the Emerson Process Management family of companies. All other marks are property of their respective owners.

